

WATERWARE ACTIVE CEILING

SPECIFICATION

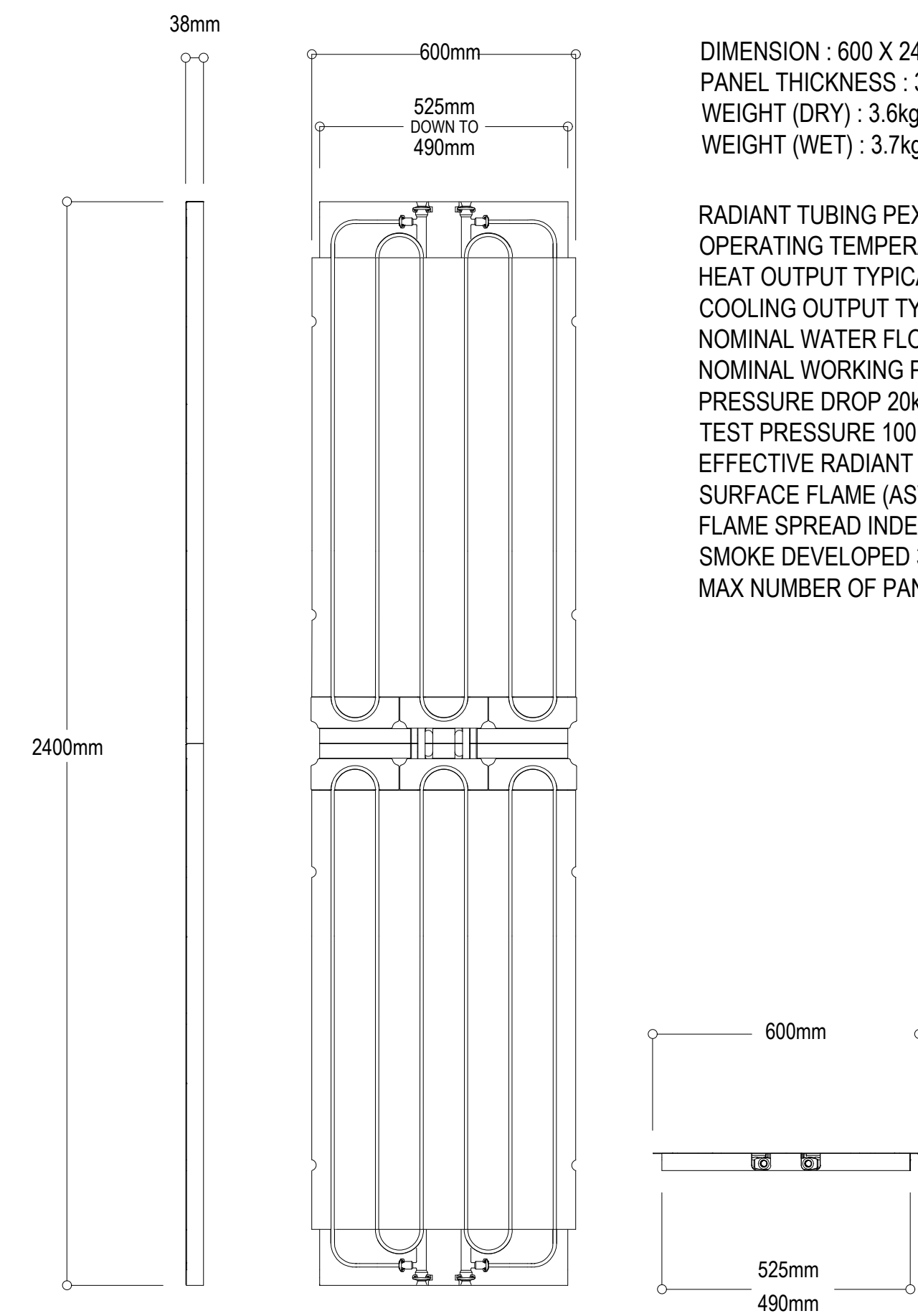

DIMENSION : 600 X 2400mm (NOMINAL)
 PANEL THICKNESS : 38mm
 WEIGHT (DRY) : 3.6kg
 WEIGHT (WET) : 3.7kg

RADIANT TUBING PEX WITH EVOH OXYGEN BARRIER DIAMETER 8.5mm O.D. - 5.5mm I.D.
 OPERATING TEMPERATURE MIN 7°C - MAX 60°C
 HEAT OUTPUT TYPICAL 140w/m²
 COOLING OUTPUT TYPICAL 90w/m²
 NOMINAL WATER FLOW 0.8L/min
 NOMINAL WORKING PRESSURE (max) 1.5 bar (6 bar)
 PRESSURE DROP 20kpa
 TEST PRESSURE 100 PSI FOR 10 MIN (REQUIRED) THEN 24H @ 60 PSI
 EFFECTIVE RADIANT SURFACE 90%
 SURFACE FLAME (ASTM84) 3 CLASS A
 FLAME SPREAD INDEX 3
 SMOKE DEVELOPED 3.5
 MAX NUMBER OF PANELS PER LOOP 12

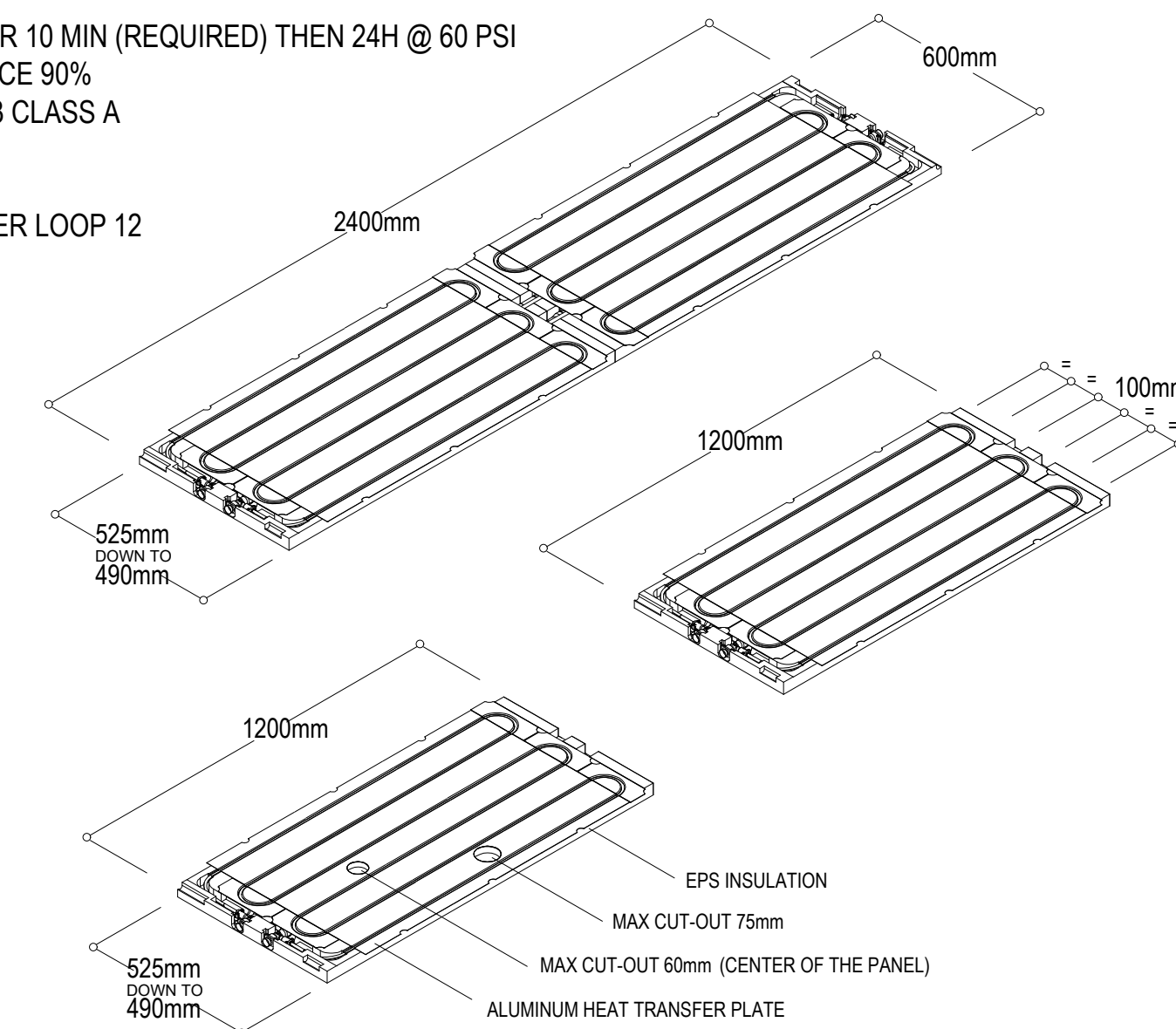

PANELS CONFIGURATION AND NOTES

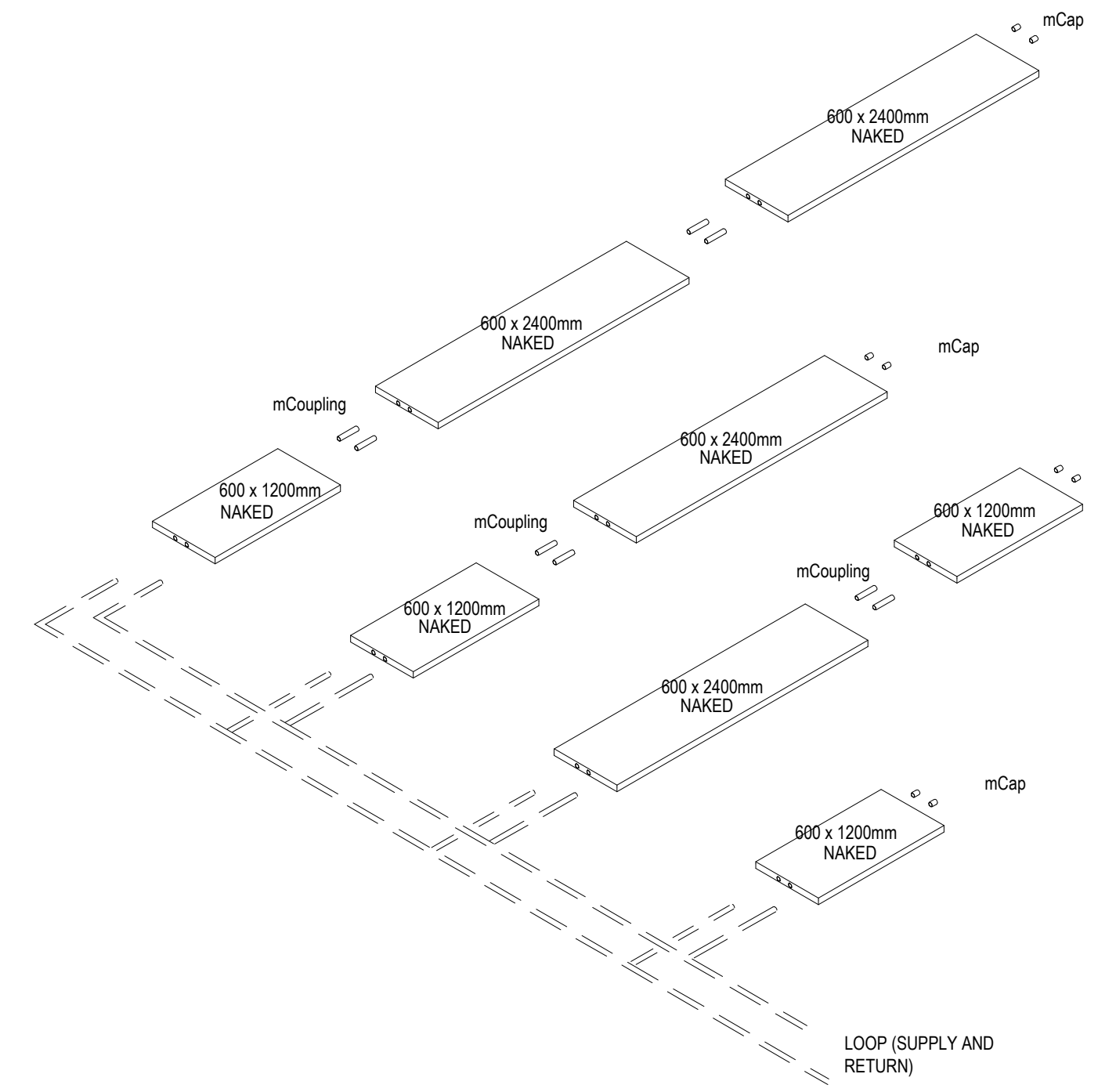

INSTALLATION WITH SECONDARY FRAMING 600mm O.C.



INSTALLATION BETWEEN CEILING JOIST 600mm O.C.



INSTALLATION WITH SECONDARY FRAMING 600mm O.C.

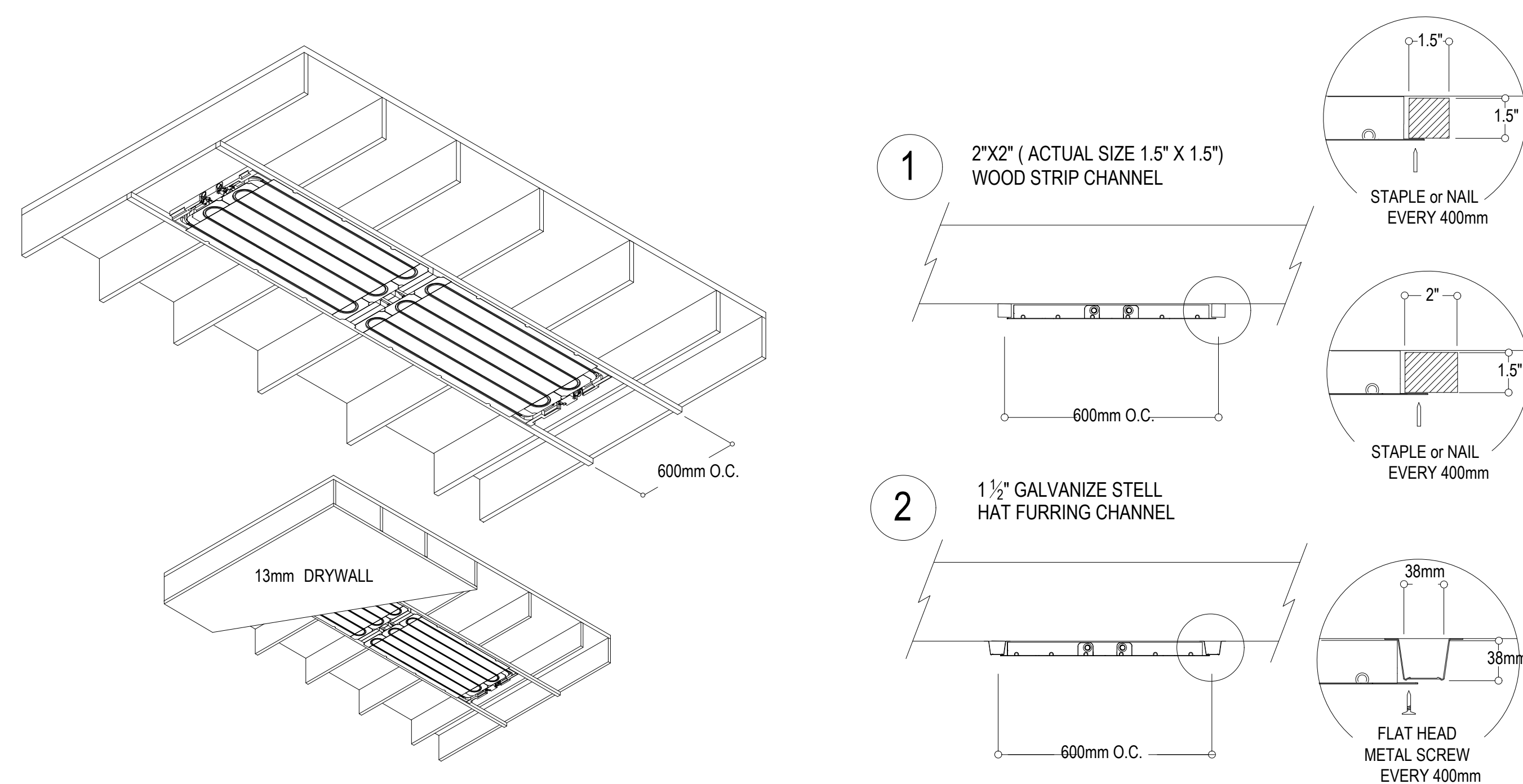

INSTALLATION BETWEEN CEILING JOIST 600mm O.C.

