

Backflow preventer, BA type, with multifunction geometry



580 series



01322/16 GB

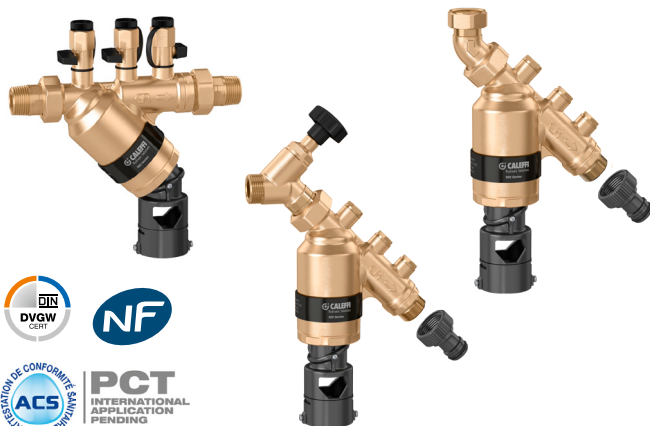

Product range

- Code 5800.0 BA type backflow preventer with multifunction geometry _____ sizes DN 15 (1/2"), DN 20 (3/4")
- Code 580150 BA type backflow preventer with multifunction geometry, with curved union, for special applications _____ size DN 20 (3/4")
- Code 5802.0 BA type backflow preventer with multifunction geometry, with isolating valve, for special applications _____ sizes DN 15 (1/2"), DN 20 (3/4")

Technical specifications

Materials:

- Body: dezincification resistant alloy **CR** EN 1982 CB752S
- Cartridge components: PPSG40, POM 13, dezincification resistant alloy **CR** EN 12164 CW724R
- Downstream check valve: POM, NBR
- Check valve stems and springs: stainless steel EN 10270-3 (AISI 302)
- Membrane: EPDM
- Cartridge locking nut: brass EN 12165 CW617N
- Downstream check valve locking nut: dezincification resistant alloy **CR** EN 12164 CW724R
- Upstream strainer: stainless steel EN 10088-2 (AISI 304)
- Strainer mesh size: 0,47 mm
- Seals: EPDM
- Discharge tundish: PP
- Hose connection (code 580150/240/250): PP
- Isolating valve body (code 5802.0): brass EN 12165 CW617N
- Isolating valve obturator (code 5802.0): dezincification resistant alloy **CR** EN 12164 CW724R
- Isolating valve control stem (code 5802.0): brass EN 12164 CW617N
- Isolating valve knob (code 5802.0): PA

Performance:

- Medium: potable water
- Nominal pressure: PN 10
- Maximum working temperature: 65°C
- Ambient temperature range: 5–50°C
- Downstream check valve opening pressure (EB type, EN 13959): 0,5 kPa
- Pressure test ports with cock: upstream, intermediate, downstream (only for codes 580040/050)

Threaded connections:

- code 5800.0: 1/2" and 3/4" M with union (EN 10226-1)
- code 580150: 3/4" nut x 3/4" M (ISO 228-1)
- code 580240: 1/2" M x 3/4" M (ISO 228-1)
- code 580250: 3/4" M x 3/4" M (ISO 228-1)
- Pressure test port connection: 1/4" F (ISO 228-1)
- Hose connection (code 580150/240/250): 3/4" M

- Certification: DVGW, ACS, NF
- Conforms to standards:
 - code 580040/050: EN 12729
 - code 580150: EN 12729, Beschluss 4/2007
 - code 580240/250: EN 12729, W570-3
- Acoustic group: II

Function

The backflow preventer is a hydraulic protection device designed to prevent polluted water from flowing back into the mains supply network. The backflow preventer is installed between the mains supply network and the internal consumer circuit in water supply systems and creates a safety zone that prevents the water in the two circuits from coming into contact. It protects the water mains from downstream overpressure, back syphonage and backflow. To EN 12729 standard in accordance with EN 1717.

The version for special applications is used for the connection of taps on stands, at trade fairs, events, construction sites and is provided with a hose connection. The backflow preventer can be used in many applications, thanks to the variety of connections on the base of a single product.

Hydraulic characteristics

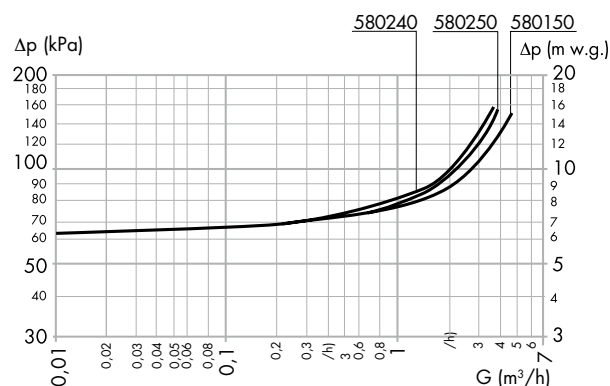
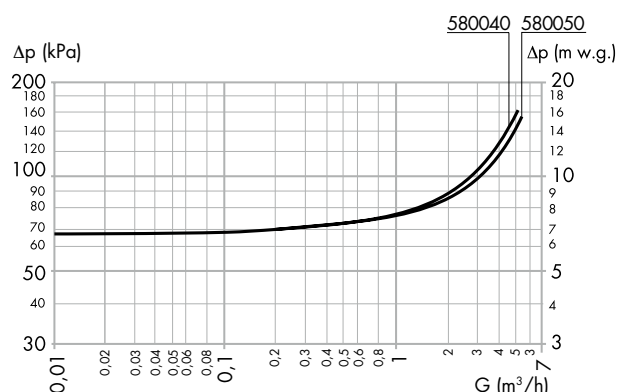

| Code | 580040 | 580050 | 580150 | 580240 | 580250 |
|---------------------------------|--------|--------|--------|--------|--------|
| Size | DN 15 | DN 20 | DN 20 | DN 15 | DN 20 |
| Connections | 1/2" | 3/4" | 3/4" | 1/2" | 3/4" |
| G (m³/h) with Δp=1 bar | 2,75 | 3 | 2,78* | 2,15* | 2,26* |
| G (m³/h) with Δp=1,5 bar | 4,7 | 5,15 | 4,78* | 3,63* | 3,78* |

Note: data determined with built-in upstream strainer installed.
 *= data determined without hose connection.

Dimensions

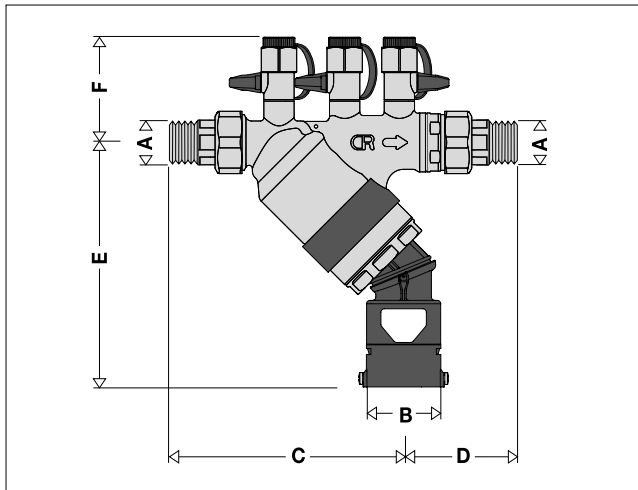

| Code | A | B | C | D | E | F | Mass (kg) |
|--------|------|------|-------|----|-----|------|-----------|
| 580040 | 1/2" | Ø 40 | 139,5 | 68 | 145 | 61,5 | 1,50 |
| 580050 | 3/4" | Ø 40 | 137,5 | 66 | 145 | 61,5 | 1,50 |

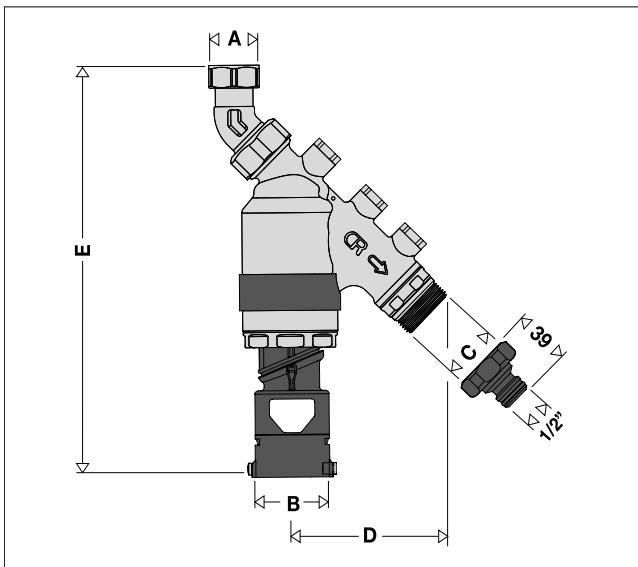

| Code | A | B | C | D | E | Mass (kg) |
|--------|------|------|------|----|-------|-----------|
| 580150 | 3/4" | Ø 40 | 3/4" | 89 | 244,5 | 1,25 |

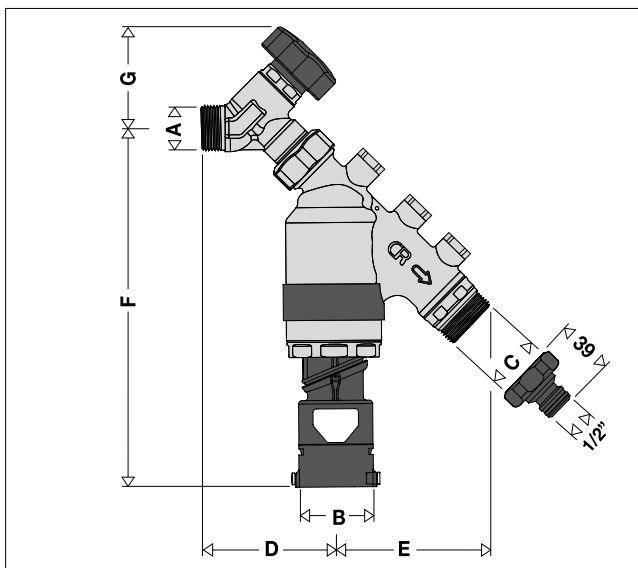

| Code | A | B | C | D | E | F | G | Mass (kg) |
|--------|------|------|------|------|----|-----|------|-----------|
| 580240 | 1/2" | Ø 40 | 3/4" | 76,5 | 89 | 213 | 60,5 | 1,45 |
| 580250 | 3/4" | Ø 40 | 3/4" | 76,5 | 89 | 213 | 60,5 | 1,45 |

Use of type BA type backflow preventers, reference to European standard

EN 1717 and EN 12729

The use of the BA type backflow preventer is regulated by the European regulations about the prevention of pollution from backflow.

The reference standard is **EN 1717:2000** "Protection against pollution of potable water in water installations and general requirements of devices to prevent pollution by backflow".

This standard classifies the water in the systems according to the level of risk it represents for human health.

Category 1: Water to be used for human consumption coming directly from a potable water distribution system.

Category 2: Fluid presenting no human health hazard, as per 1, the quality of which can have undergone a change in taste, odour, colour or temperature.

Category 3: Fluid representing some human health hazard due to the presence of one or more harmful substances.

Category 4: Fluid presenting a human health hazard due to the presence of one or more "toxic" or "very toxic" substances or one or more radioactive, mutagenic or carcinogenic substances.

Category 5: Fluid presenting a human health hazard due to the presence of microbiological or viral elements.

According to this classification, suitable backflow prevention devices must be fitted in water distribution circuits.

BA type backflow preventers can be used to protect against the risk of pollution from backflow for types of water up to category 4. For category 5 types of water an air gap separation must be used.

The table entitled "Protection matrix" lists a series of systems with category 4 medium based on the indications provided in the European regulation.

European regulation **EN 12729** "Devices to prevent pollution by backflow of potable water" Controllable backflow preventer with reduced pressure zone. Family B - Type A" defines the functional, dimensional and mechanical requirements of controllable reduced pressure zone backflow preventers of type BA.

Backflow

Potable water, flowing in the mains supply network, may suffer from hazardous pollution mainly caused by contaminated fluid return, coming back from systems directly connected to the main supply. This phenomenon, termed "backflow", occurs when:

- the pressure in the mains system is lower than the pressure in the downstream hydraulic circuit (back syphonage). This situation may occur when there is a pipe breaking in the mains system or when demand on the mains supply network by consumers is very heavy.
- the pressure in the downstream circuit rises (back pressure/downstream overpressure) due, for example, to water being pumped from a well.

Risk assessment

Given the potential danger of the phenomenon and the requirements of current regulations, the risk of pollution by backflow must be assessed on the basis of the type of system and the characteristic of the fluid that flows in it. An appropriate backflow prevention device must be selected on the basis of that assessment performed by the system designer and the mains supply Company. The device must be located along the supply line at those points at risk of backflow which would be hazardous to human health.

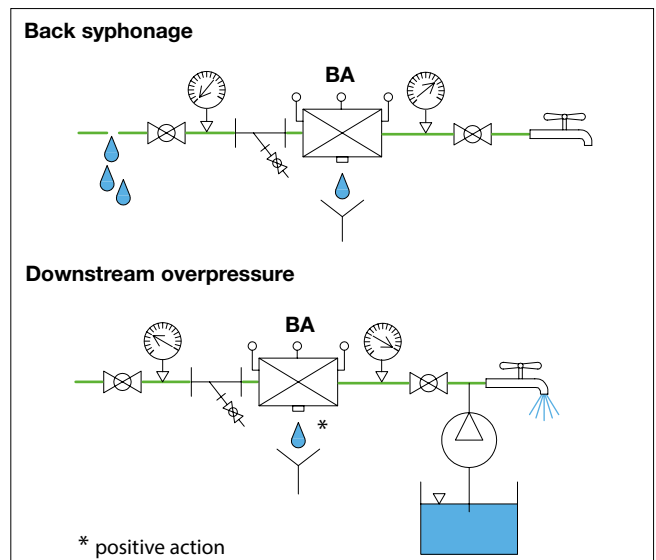

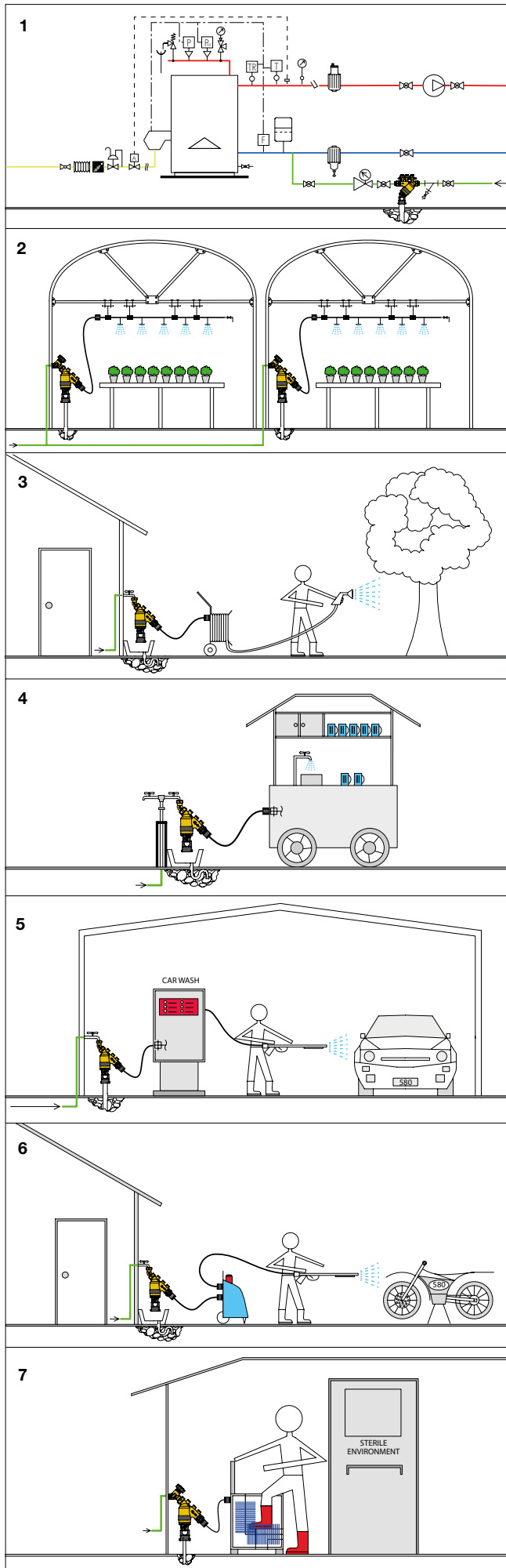

Protection matrix

| Type of system with category 4 medium |
|--|
| General |
| Filling of heating systems with/without additives (fig. 1) |
| WC: filling of tank with float |
| Filling of forced circulation solar thermal systems |
| Filling of closed circuits with dosing devices for additives such as softeners or demineralization units |
| Toilet cleaning systems with chemicals and disinfectants |
| Bathtub filling and cleaning system with water outlet below the edge of the tub (immersed) |
| Filling of swimming pools |
| Hairdressers' shampoo basins |
| Domestic or residential gardens |
| Mini-irrigation systems, without fertilizers or insecticides, as pop-up sprinklers or porous pipes (fig. 2) |
| Cock with hose connection (fig. 3) for connecting pipes with a risk of backflow |
| Food processes |
| Dairies |
| Food preparation |
| Medical |
| Disinfecting systems |
| Cooling of radiography appliances |
| Catering |
| Dish-washing machines in commercial buildings |
| Beverage distributors in which the ingredients or CO ₂ are injected in the inlet or distribution pipe |
| Refrigeration appliances |
| Machines for washing beer tanks |
| Appliances for cleaning pipes that convey beverages in restaurants |
| Connection with mobile structures of stands and recreational areas (fig. 4) |
| Industrial and commercial applications |
| Breweries and distillers |
| Car washing and degreasing systems (fig. 5) |
| Commercial laundries |
| Dry-cleaning appliances |
| Printing and photographic appliances |
| Water treatment or softening systems that use products other than salt |
| Washing/disinfecting systems with injection of detergents |
| Humidifying appliances |
| Dosing devices with cat. 4 mediums for non-potable applications |
| Treatment with inverse osmosis |
| High-pressure cleaner (fig. 6) |
| Agriculture |
| Boot washing systems for access to protected environments (fig. 7) |
| Milking machines, cleaning machine with addition of disinfectant |

Operating principle

The controllable reduced pressure zone backflow preventer is composed of: a body (1); a self-contained cartridge (2) equipped with an upstream check valve (3); a downstream check valve (4); a discharge device integrated with the cartridge (5). The two check valves mark off three different zones, each of which at a different pressure: an upstream or inlet zone (A); an intermediate zone, also known as the reduced pressure zone (B); a downstream or outlet zone (C). Each of these is equipped with a test port for pressure measurement. A discharge device (5) is located in the lower part of the intermediate zone. The obturator of the discharge device is connected to the membrane (6). This mobile unit is pushed upwards by the spring (7). The membrane (6) separates the upstream zone from the intermediate zone.

Correct flow conditions

Under normal flow conditions, both check valves (3 and 4) are open, while the pressure in the intermediate chamber (B) is always lower than the inlet pressure (upstream A) by at least 14 kPa due to the pressure loss caused by the check valve (3). In this situation, the mobile unit consisting of the membrane (6) and the valve obturator (5) is pushed down by the thrust created by the difference in pressure acting on the membrane which is greater than that of the spring (7) acting in the opposite direction. The discharge valve (5) is therefore held in the closed position.

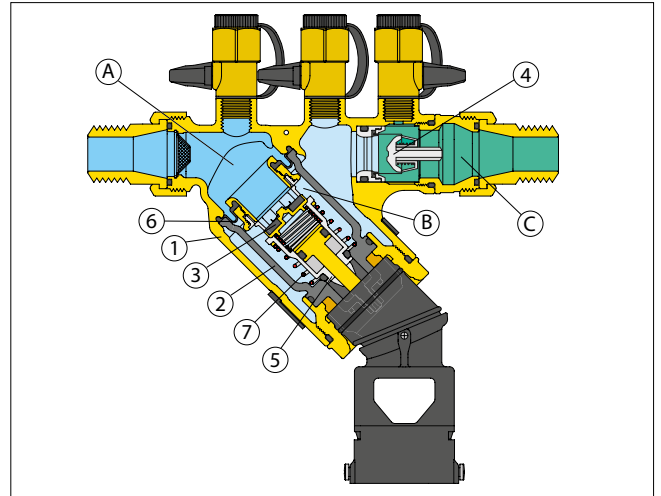

No flow conditions

The check valves (3 and 4) are now closed. Since the pressure in the upstream zone (A) is still at least 14 kPa higher than the pressure in the intermediate chamber (B), the discharge valve (5) remains closed.

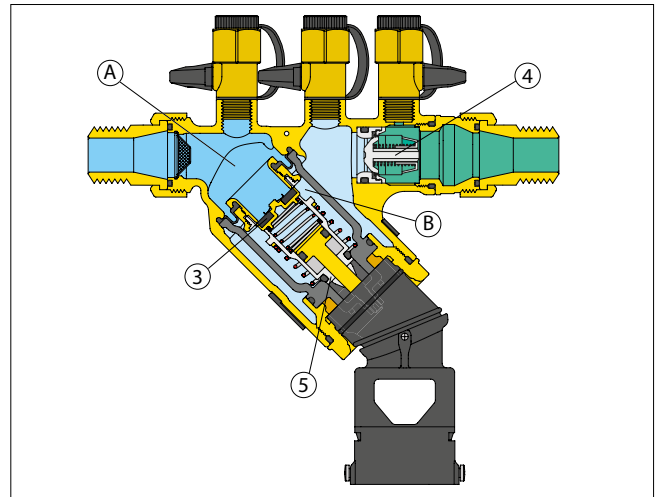

Upstream pressure loss

The check valves (3 and 4) close as the pressure upstream (A) drops. The discharge valve (5) opens when the difference in pressure Δp , between the upstream (A) and the intermediate (B) zones, falls reaching a value a little bit higher than 14 kPa. Under these conditions the action exerted by the pressure difference Δp on the membrane (6) becomes weaker than that exerted by the spring (7) and the discharge valve (5) opens as a result. Discharge then occurs until the body of the backflow preventer is empty. When the situation returns to normal (upstream pressure (A) greater than downstream pressure (C)), the discharge valve (5) closes and the backflow preventer is again ready to operate.

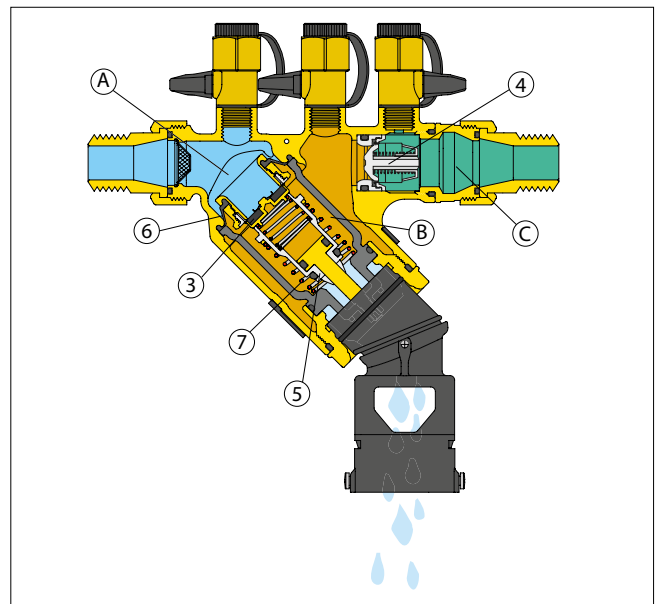

Downstream back pressure

If the pressure in the downstream zone (C) increases until it exceeds the upstream pressure value (A), the check valve (4) closes, thus preventing the water that has already been sent to the user from flowing back towards the water main. If the seal of the check valve (4) is slightly defective or in general terms there is any other type of fault in the backflow preventer, the device always interrupts (disconnects) the connection between the mains system and the user system. The backflow preventer has been designed with all construction details required for a properly functioning positive action device; the best possible safety conditions are therefore ensured under all conditions.

Construction details

Self-contained cartridge

The self-contained cartridge comprises, all in one piece, the membrane, the upstream check valve, the discharge valve and the whole activation system. In case of maintenance, it can be easily extracted from the body without the aid of further sealing elements.

Membrane

The membrane, integrated with the cartridge, separates the upstream zone from the intermediate zone. It also acts as a hydraulic seal between the two zones. For this reason there are no O-rings between the two zones.

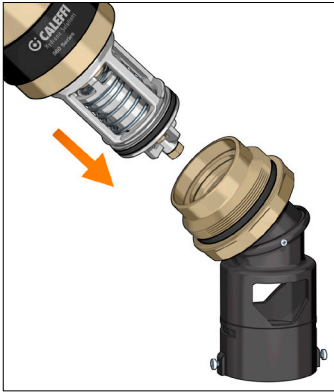

Built-in upstream strainer

The upstream strainer, required by the protection unit according to regulation EN 1717, is located in the upstream connection of the valve body and is easily accessible for maintenance (see paragraph Installation).

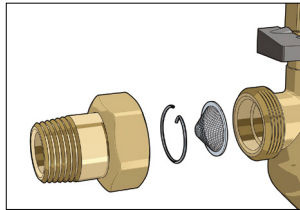
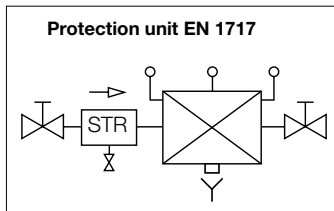

Discharge tundish

In compliance with standard EN 1717, backflow from the connected pipe must be prevented during discharge and this must occur without any water sprinkling to the outside. Consequently the tundish connected to the discharge pipe must be of an appropriate size with special openings to create the necessary air gap and it must be equipped with a proper flow conveyor. Thanks also to the possibility of orienting the tundish, the same body can be used in three different configurations: installation on horizontal or vertical pipes or for special applications.

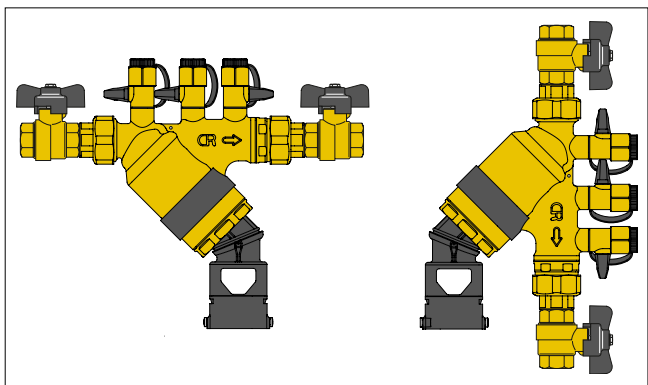

Downstream check valve

The downstream check valve is positioned before the outlet connection and is held in place by a special locking nut. For maintenance, just remove the downstream union and the locking nut.

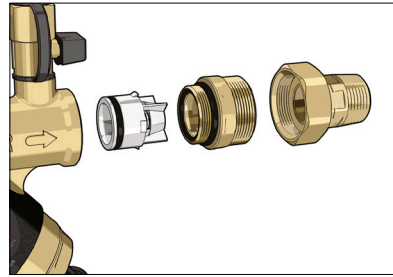

Hose connection

The version for special applications is provided as standard with a 3/4" hose connections on the outlet connection.

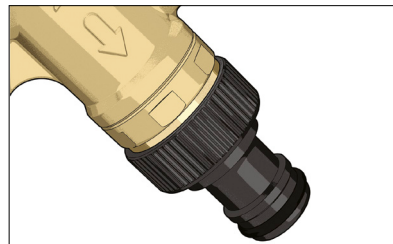

Versatility

The version for in-line installation (on a horizontal or vertical pipe) can be easily converted into a version for special applications, and vice versa, thanks to the interchangeability of the upstream union with the elbow union and the isolating valve upstream.

Thanks to the compactness and versatility of the body, the 580 series backflow preventer is suitable for protecting systems with mediums of even lower than category 4, so that only one device need be kept in stock.

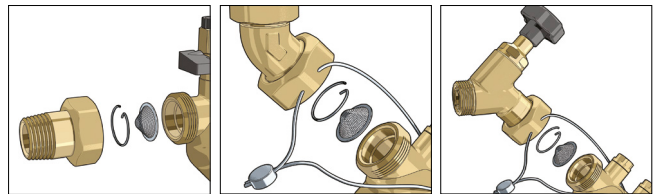

Corrosion-proof materials

The materials used to manufacture the backflow preventers must be insensitive to corrosion caused by contact with drinking water. They are therefore constructed using a dezincification resistant alloy, plastic materials and stainless steel to ensure high performance over time.

Easy maintenance

The backflow preventer is a device that must undergo periodic checking of its operating status during its normal working life, as required by regulation EN 806-5. When needed, any disassembly and maintenance work is easier to perform thanks to the use of components easy to verify and replace without having to disassemble the valve body from the pipe.

Certification

580 series BA type controllable reduced pressure zone backflow preventers are certified as compliant with national and European product specifications by DVGW, ACS and NF.

Installation

The backflow preventer must be installed in an accessible zone, where there is no risk of accidental flooding or frost. If there is a risk of frost, especially for the backflow preventer version for special applications, it is recommended to remove the device during the coldest hours. The discharge tundish must be turned downwards and connected to the pipe leading to the sewer.

For the protection of the public mains the backflow preventer must be installed after the water meter, whereas in order to protect the tap water outlets of the domestic internal network it should be installed at the limit of the areas where there may be contamination due to backflow.

The in-line backflow preventer, codes 580040/050, must be installed with one isolating valve upstream and one downstream (not supplied in the package). According to the indications of regulation EN 1717, the backflow preventer is equipped with an inspectable strainer, located in the upstream connection of the body and easily accessible for maintenance, and an adjustable discharge tundish. The appliance should be installed horizontally, in accordance with the flow direction indicated by the arrow on the valve body. Installation on a vertical pipe with downward flow (from top to bottom) is also allowed, respecting the direction of flow indicated by the arrow on the valve body. In the case of particularly dirty mediums, consider installing an additional inspectable strainer upstream.

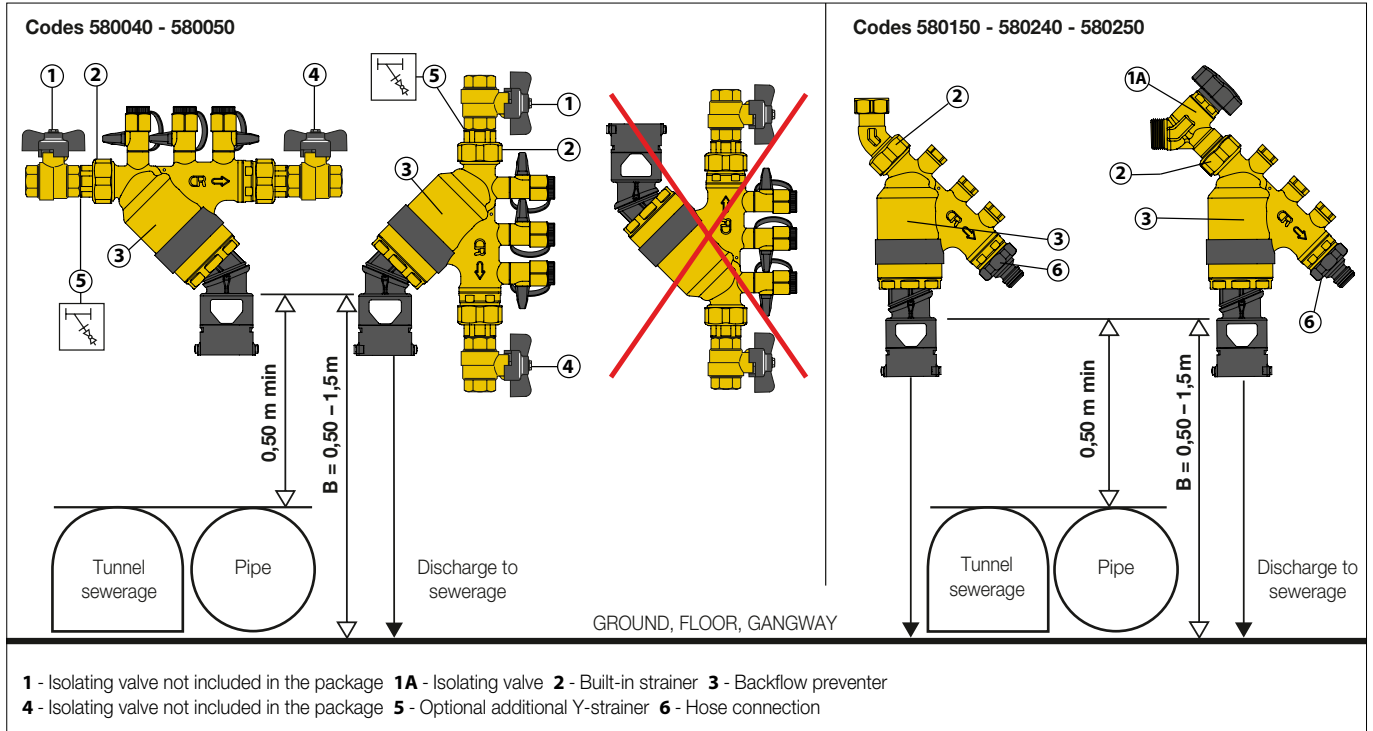

The backflow preventer for special applications code 580150, equipped with a captive nut, must be fitted to the cock which thus performs the function of an upstream isolating valve. The backflow preventer for special applications 580240/250 must be fitted directly to the pipe, as it is already equipped with an upstream isolating valve. The connection between valve, fitting and backflow preventer can be blocked with a specific seal. According to the indications of regulation EN 1717, the backflow preventer is equipped with an inspectable strainer, located in the upstream connection of the body and easily accessible for maintenance, and an adjustable discharge tundish. The appliance must be installed with a downward flow (from top to bottom), respecting the direction of flow indicated by the arrow on the valve body. In the case of particularly dirty mediums, consider installing an additional inspectable strainer upstream.

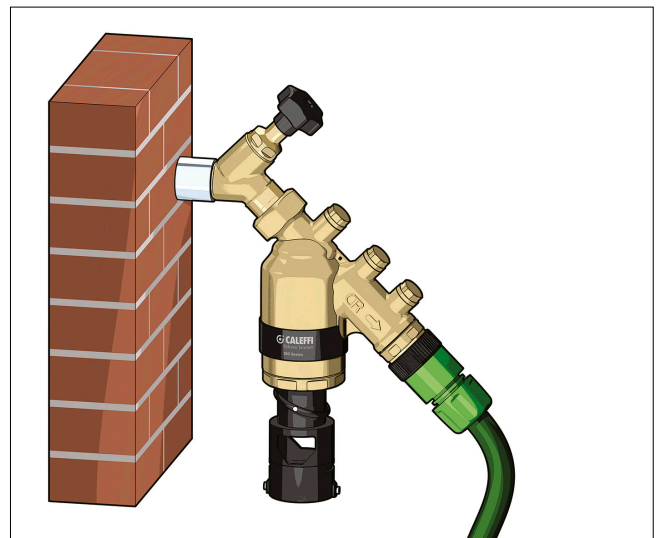
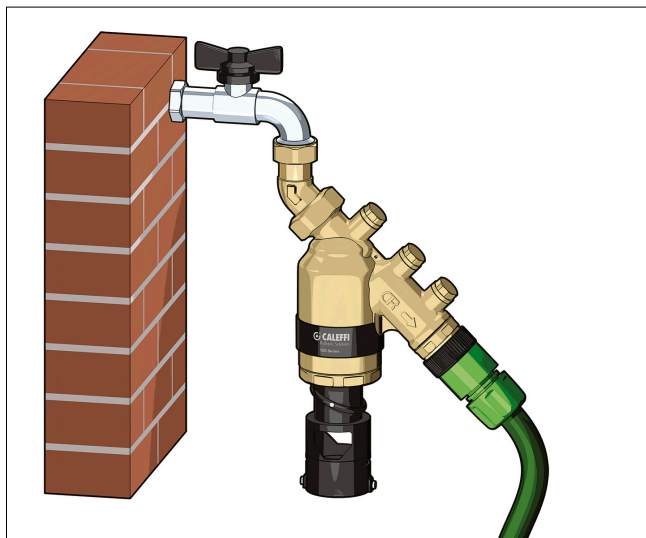

Inspection and maintenance

The backflow preventer is a health and safety device that requires periodic inspection. According to EN 806-5 regulation, BA type backflow preventers should be inspected once every six months and undergo routine maintenance once a year.

The first indication of poor operation, generally caused by foreign matter (sand or other debris), is revealed with a permanent discharge from the discharge valve. This discharge does not affect safety, but requires disassembly and cleaning of the appliance and of the upstream strainer incorporated in the upstream connection of the body. The quick checking method is specified in the table shown below.

For checking of backflow preventers for special applications codes 580150/240/250 fit an isolating valve in place of the hose connection.

The visual and functional checks, described in regulation EN 806-5, include: checking any variations in use of the water downstream, checking installation requirements, cleaning the strainer and the discharge tundish, checking the operation of check valves and seals, discharge opening/closing tests, measuring pressures with appropriate instruments (static, dynamic, differential). It is prohibited to by-pass the backflow preventer, so it is good practice to procure a spare device in the case of critical installations.

Functional checking of the backflow preventer can be carried out by means of a differential pressure gauge, with two Tee fittings each of which with a pressure release cock.

Quick checking method

Check that the system is under pressure before each operation and watch the discharge valve located on the lower part of the device (use a mirror if necessary).

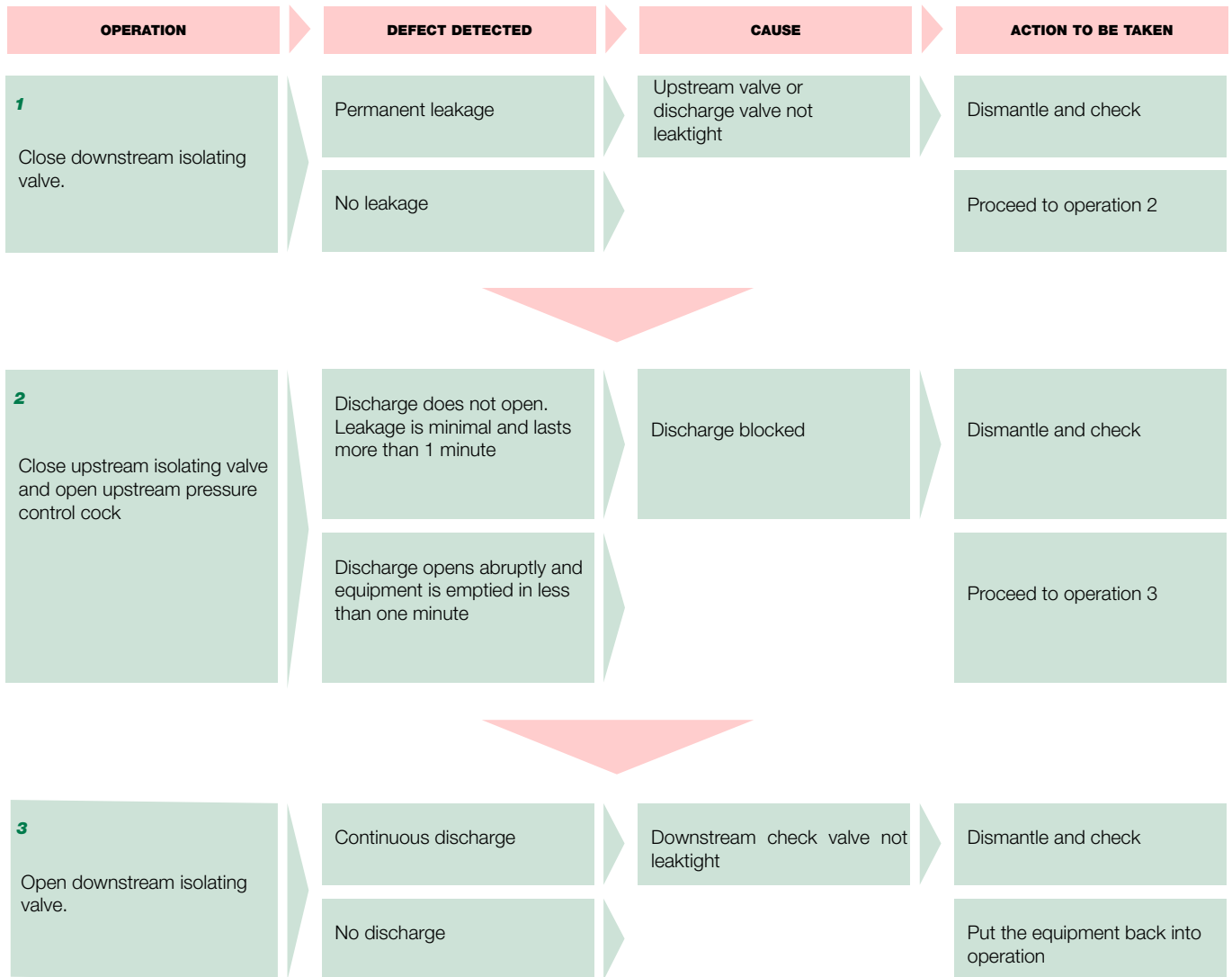

N.B. : In normal operation the appliance must not present any permanent leakage. Otherwise dismantle and verify.

Accessories



Code R59343

Pressure test port with cock
 Threaded connections 1/4" M (ISO 228-1).

SPECIFICATION SUMMARY

Code 5800.0

Controllable reduced pressure zone backflow preventer with multifunction geometry. BA type. Certified to EN 12729 standard. Size DN 15 (and DN 20). Threaded connections 1/2" (and 3/4") M (EN 10226-1) with union. Dezincification resistant alloy body. Self-contained cartridge in dezincification resistant alloy, PPSG40, POM 13. Downstream check valve in POM. Stainless steel check valve stem and springs. EPDM membrane. Brass locking nut for cartridge. Downstream check valve in dezincification resistant alloy. Stainless steel upstream strainer; strainer mesh size 0,47 mm. EPDM seals. Adjustable discharge tundish in PP. Medium drinking water. Nominal pressure PN 10. Maximum working temperature 65°C. Ambient temperature range 5–50°C. Downstream check valve opening pressure (EN 13959) 0,5 kPa. Complete with pressure test ports: upstream, intermediate, downstream. Acoustic group II.

Code 580150

Controllable reduced pressure zone backflow preventer with multifunction geometry, with curved union, for special applications. BA type. Certified to EN 12729 standard. Size DN 20. Threaded connections 3/4" with nut x 3/4" M (ISO 228-1). Dezincification resistant alloy body. Self-contained cartridge in dezincification resistant alloy, PPSG40, POM 13. Downstream check valve in POM. Stainless steel check valve stem and springs. EPDM membrane. Brass locking nut for cartridge. Downstream check valve in dezincification resistant alloy. Stainless steel upstream strainer; strainer mesh size 0,47 mm. EPDM seals. Adjustable discharge tundish in PP. Medium drinking water. Nominal pressure PN 10. Maximum working temperature 65°C. Ambient temperature range 5–50°C. Downstream check valve opening pressure (EN 13959) 0,5 kPa. Complete with 3/4" hose connection on the outlet connection. Acoustic group II.

Code 5802.0

Controllable reduced pressure zone backflow preventer with multifunction geometry, with isolating valve, for special applications. BA type. Certified to EN 12729 standard. Size DN 15 (and DN 20). Threaded connections 1/2" M x 3/4" F (and 3/4" M x 3/4" M) (ISO 228-1). Dezincification resistant alloy body. Self-contained cartridge in dezincification resistant alloy, PPSG40, POM 13. Downstream check valve in POM. Stainless steel check valve stem and springs. EPDM membrane. Brass locking nut for cartridge. Downstream check valve. Stainless steel upstream strainer; strainer mesh size 0,47 mm. EPDM seals. Adjustable discharge tundish in PP. Complete with upstream isolating valve with obturator in dezincification resistant alloy, brass control stem, knob in PA. Medium drinking water. Nominal pressure PN 10. Maximum working temperature 65°C. Ambient temperature range 5–50°C. Downstream check valve opening pressure (EN 13959) 0,5 kPa. Complete with 3/4" hose connection on the outlet connection. Acoustic group II.

Code R59343

Pressure test port with cock. Brass body. Threaded connections 1/4" F (ISO 228-1).

We reserve the right to make changes and improvements to the products and related data in this publication, at any time and without prior notice.



Caleffi S.p.A.
S.R. 229 n. 25 · 28010 Fontaneto d'Agogna (NO) · Italy
Tel. +39 0322 8491 · Fax +39 0322 863723
info@caleffi.com · www.caleffi.com
© Copyright 2016 Caleffi