

For the competent person

Installation instructions

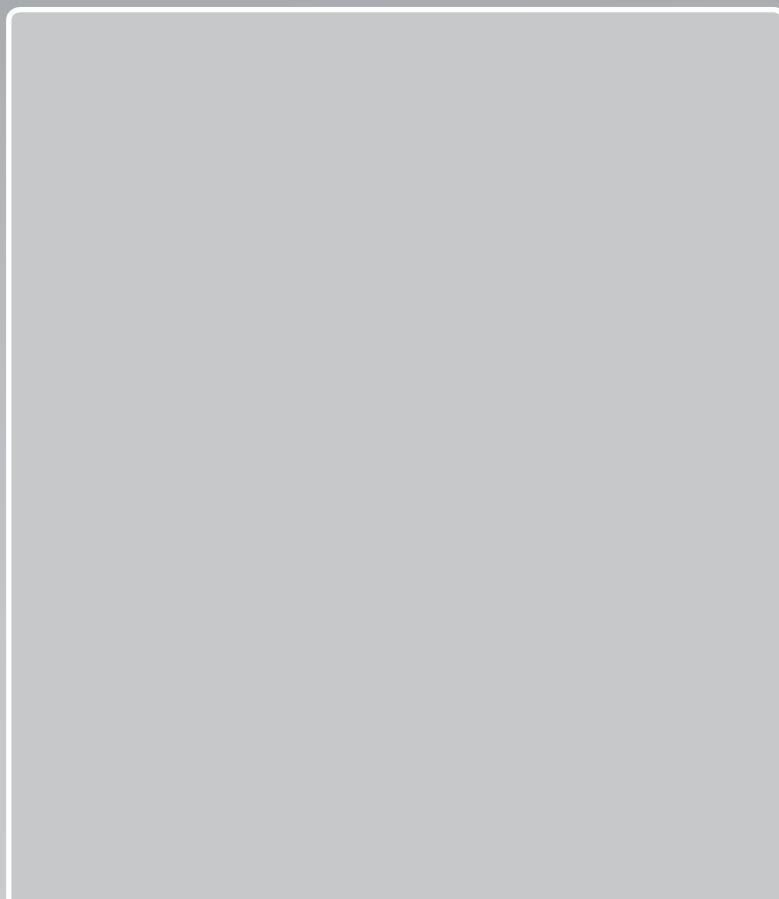

VR 70

GB, IE

Publisher/manufacturer

Vaillant GmbH

Berghauser Str. 40 ■ D-42859 Remscheid
Telefon 021 91 18-0 ■ Telefax 021 91 18-28 10
info@vaillant.de ■ www.vaillant.de



Contents

Contents

1	Safety	3
1.1	General safety information	3
1.2	Requirements for lines	3
1.3	Regulations (directives, laws, standards)	3
1.4	Intended use	3
2	Notes on the documentation	5
2.1	Observing other applicable documents	5
2.2	Storing documents	5
2.3	Applicability of the instructions	5
3	Product overview	5
3.1	CE label	5
3.2	Design of the product	5
3.3	How it works	5
3.4	Identification plate	5
3.5	Checking the scope of delivery	5
4	Installation	6
5	Electrical installation	6
5.1	Setting the bus address	7
6	Decommissioning	7
7	Recycling and disposal	8
8	Customer service	8
9	Technical data	8

1 Safety

1.1 General safety information

1.1.1 Risk of death from live connections

There is a risk of death from electric shock when working on the product when it is open.

- ▶ Switch the main switch off before removing the cover to work on the product.
- ▶ Disconnect the product from the power mains by de-energising the product using a partition with a contact opening of at least 3 mm (e.g. fuses or power switches).
- ▶ Check that the product is de-energised.
- ▶ Secure the power supply against being switched on again.

1.1.2 Material damage due to unsuitable installation room

If you are installing the product in a moist environment, the electronics may be damaged by moisture.

- ▶ Only install the product in dry rooms.

1.1.3 Danger due to error functions

- ▶ Ensure that the heating system is in a technically perfect condition.
- ▶ Ensure that no safety or monitoring devices have been removed, bridged or disabled.
- ▶ Immediately rectify any faults and damage that may affect safety.
- ▶ At lengths of over 10 m, 230 V supply cables must be laid separately from sensor or bus lines.
- ▶ Secure all supply lines in the casing using the enclosed strain relief.
- ▶ Do not use the unit's free terminals as supports for other wiring.

1.2 Requirements for lines

- ▶ Use standard commercial lines for the wiring.
- ▶ Do not use flexible lines for 230 V lines.
- ▶ Use sheathed cables for 230 V lines (e.g. NYM 3 x 1.5).

Minimum cross-section

Supply line 230 V (pump or mixer mains cable)	$\geq 1.5 \text{ mm}^2$
eBUS line (extra-low voltage)	$\geq 0.75 \text{ mm}^2$
Sensor line (extra-low voltage)	$\geq 0.75 \text{ mm}^2$

Maximum line length

Sensor lines	$\leq 50 \text{ m}$
Bus lines	$\leq 125 \text{ m}$

1.3 Regulations (directives, laws, standards)

- ▶ Observe the national regulations, standards, guidelines and laws.

1.4 Intended use

In the event of inappropriate or improper use, damage to the product and other property may arise.

This product is a system component that enhances the system's functionality. A controller controls and regulates the functions via an eBUS interface.

Operation is permissible with the following component:

– VRC 700

Intended use includes the following:

- observance of accompanying operating, installation and servicing instructions for the product and any other system components
- compliance with all inspection and maintenance conditions listed in the instructions.

This product can be used by children over eight years old and also by persons with limited physical, sensory or mental capabilities or insufficient experience and/or knowledge if they are supervised or have been provided with instructions on how to safely use the product, and they understand the risks resulting from using the product. Children must not play with the product. Cleaning and user maintenance work must not be carried out by children unless they are supervised.

Any other use that is not specified in these instructions, or use beyond that specified in this document shall be considered improper

1 Safety

use. Any direct commercial or industrial use is also deemed to be improper.

Caution.

Improper use of any kind is prohibited.

2 Notes on the documentation

2.1 Observing other applicable documents

- ▶ You must observe all the operating and installation instructions included with the system components.

2.2 Storing documents

- ▶ Pass these instructions and all other applicable documents on to the system operator.

2.3 Applicability of the instructions

These instructions apply only to:

VR 70 – Article number

Great Britain	0020184844
---------------	------------

3 Product overview

3.1 CE label



The CE label shows that the products comply with the basic requirements of the applicable directives as stated on the identification plate.

The declaration of conformity can be viewed at the manufacturer's site.

3.2 Design of the product

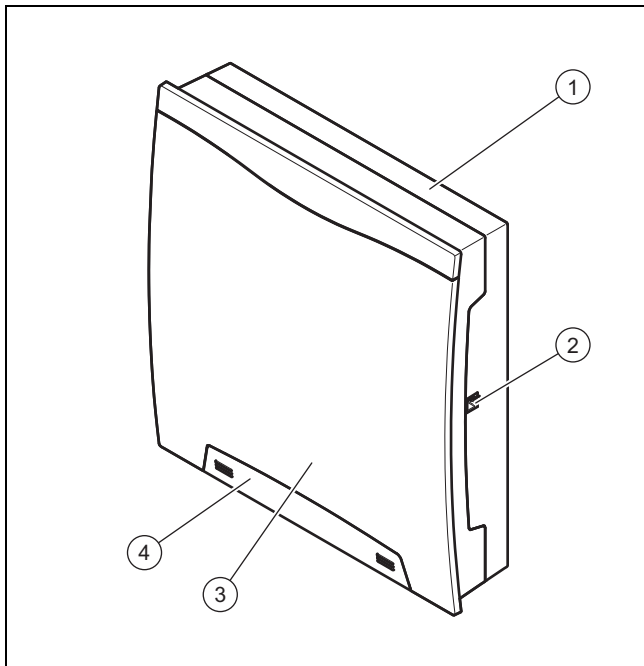

- | | | | |
|---|--------------------|---|----------------------------------|
| 1 | Wall-mounting base | 3 | Front casing |
| 2 | Diagnostics socket | 4 | Front panel for the fixing screw |

3.3 How it works

The product has inputs and outputs. By assigning the inputs and outputs in different ways, you can set up various systems. The inputs and outputs are configured using the controller.

3.4 Identification plate

The identification plate is located on the right-hand side of the casing.

Information on the identification plate	Meaning
Serial number	For identification
VR 70	Product description
V	Operating voltage
W	Power consumption
	Switching capacity for each relay and overall switching capacity
	Product complies with European standards and directives
	Proper disposal of the product

3.5 Checking the scope of delivery

Quantity	Component
1	VR 70
2	VR 10
1	Installation accessories (bolts and rawl plugs)
1	Installation instructions

- ▶ Check that the scope of delivery is complete.

4 Installation

4 Installation

Opening the product

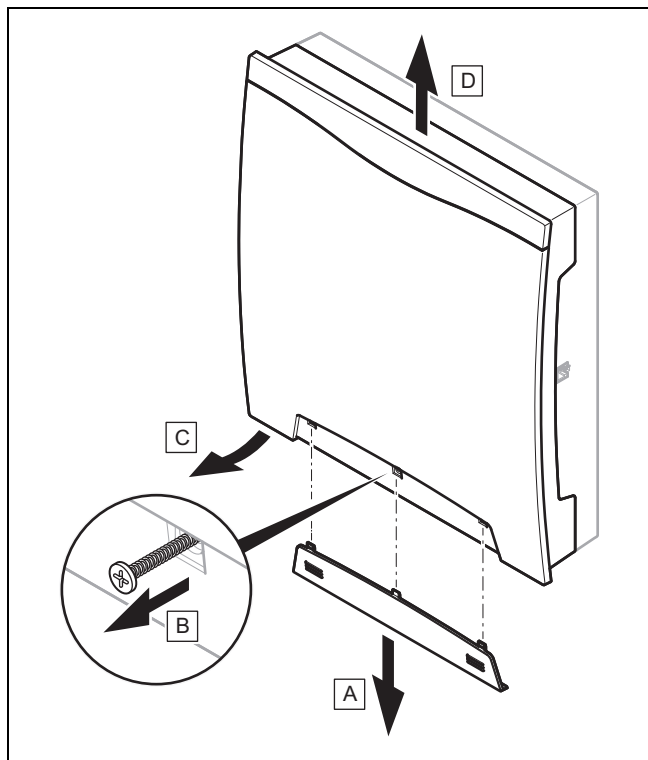

1. Open the product in accordance with the illustration.

Installing the product

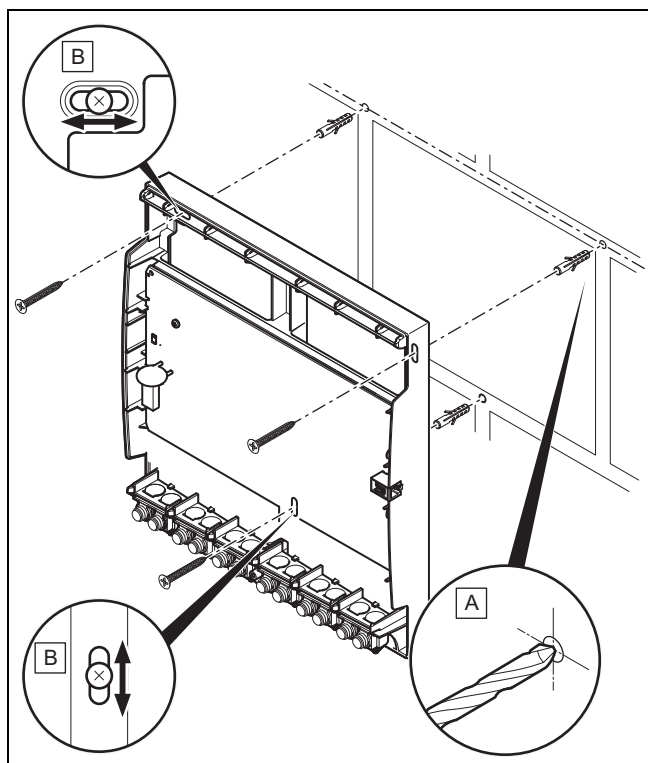

2. Install the product using the appropriate fastening material in accordance with the illustration.
3. Connect the product. (→ Page 6)

Closing the product

4. Mount the front casing at the top of the wall socket.
5. Use the fixing screw to secure the front casing.

6. Slide the front panel over the fixing screw until the front panel clicks into place.

5 Electrical installation



Danger!

Risk of electric shock

There is a risk of electric shock when working on electrical components that are connected to the low-voltage network.

- ▶ Disconnect the product from the power supply.
- ▶ Secure the product against being switched back on again.
- ▶ Check that the product is de-energised.
- ▶ Only open the product when it is de-energised.

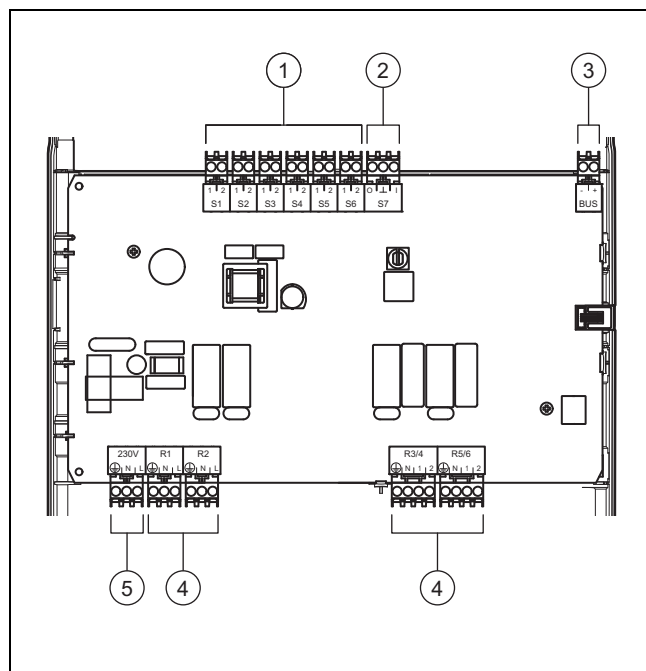

- | | | | |
|---|------------------|---|------------------|
| 1 | Input | 4 | Output |
| 2 | Input and output | 5 | Mains connection |
| 3 | eBUS | | |

1. Connect the required inputs and outputs from the selected system diagram.
2. Connect the product using a fixed connection and a partition with a contact opening of at least 3 mm (e.g. fuses or power switches).



Danger!

Risk of damage caused by incorrect installation.

Connecting wires that have been stripped back too far may cause short circuits and damage the electronics if a strand accidentally comes loose.

- ▶ Only strip the outer sheathing of flexible cables to a maximum of 2.5 cm to prevent short circuits.
- ▶ Lay the lines correctly.
- ▶ Use the strain relief.

3. Do not damage the insulation on the connecting wires when you strip the outer sheathing of the line.

Connecting the line to the upper terminal block

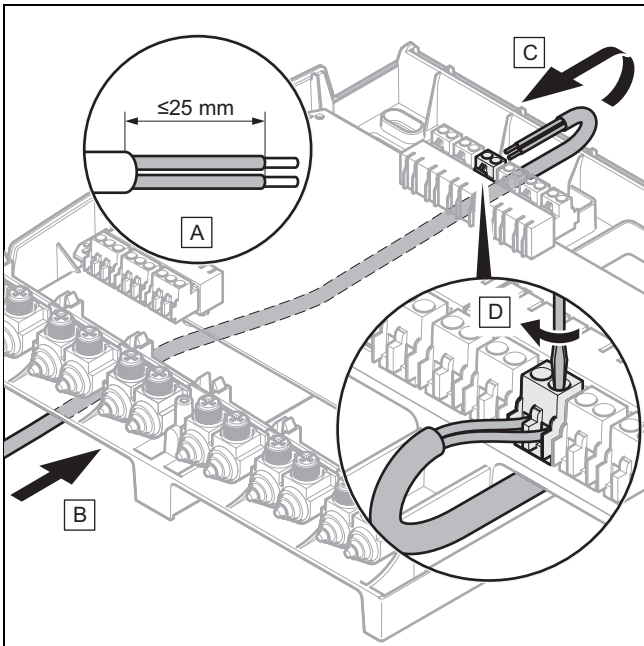

4. Connect the required inputs and outputs in accordance with the illustration.
5. Connect the eBUS line to the terminal strip in the controller's wall socket.

Connecting the line to the lower terminal block

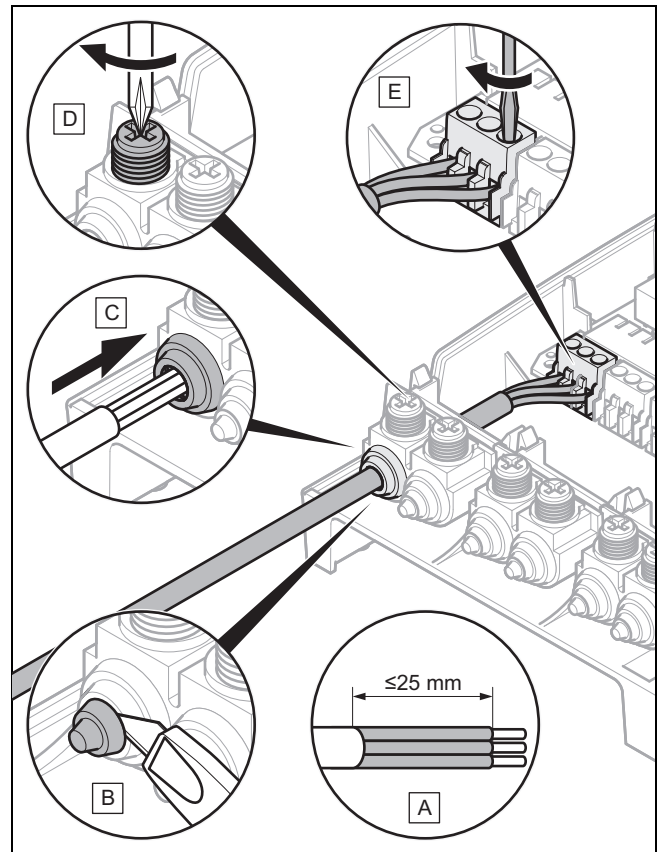

6. Connect all of the required lines in accordance with the illustration.
7. Set the bus address. (→ Page 7)
8. Close the product. (→ Page 6)

5.1 Setting the bus address

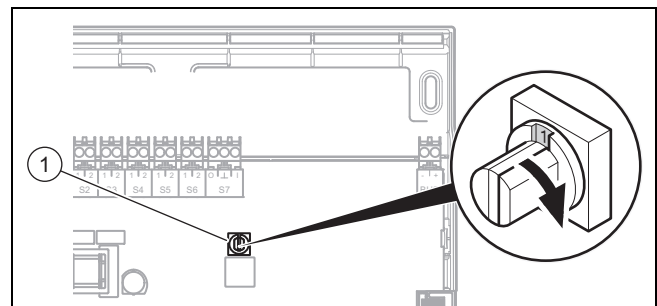

- 1 Address switch

- ▶ Assign a unique address to each VR 70 that is connected, beginning with Address 1.

6 Decommissioning

1. Decommission the heating installation if you want to replace the product.
2. Disconnect the product from the power mains by de-energising the product using a partition that has a contact opening of at least 3 mm.
3. Check that the product is de-energised.
4. Secure the power supply against being switched on again.

7 Recycling and disposal

5. Open the product. (→ Page 6)
6. Disconnect the lines from the product's terminal block.
7. Unscrew the wall-mounting base from the wall.

7 Recycling and disposal

- ▶ The competent person who installed your product is responsible for the disposal of the packaging.



If the product is identified with this symbol:

- ▶ In this case, do not dispose of the product with the household waste.
- ▶ Instead, hand in the product to a collection centre for old electrical or electronic appliances.



If the product contains batteries that are marked with this symbol, these batteries may contain substances that are hazardous to human health and the environment.

- ▶ In this case, dispose of the batteries at a collection point for batteries.

8 Customer service

To ensure regular servicing, it is strongly recommended that arrangements are made for a Maintenance Agreement. Please contact Vaillant Service Solutions (0870 6060 777) for further details.

9 Technical data

Max. operating voltage	230 V
Total current	≤ 4 A
Rated surge voltage	2,500 V
Max. extra-low voltage (ELV)	24 V _{AC}
Safety extra-low voltage (SELV)	24 V _{AC}
Mode of operation	Type 1.B.C.Y
Connection type	Y
Level of protection	IP 20
Protection class	I
Degree of contamination	2
Ambient temperature	0 ... 60 °C
Rel. air humidity	29 ... 95 %
Height	293 mm
Width	277 mm
Depth	68 mm

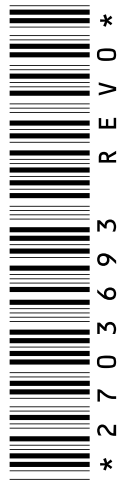

0020198787_00 ■ 24.02.2015

Vaillant Ltd

Nottingham Road ■ Belper ■ Derbyshire ■ DE56 1JT
Telephone 44 84 56 02 29 22 ■ Vaillant Service Solutions 44 807 06 06 07 77
Spares Technical Enquiries 44 17 73 59 66 15
info@vaillant.co.uk ■ technicalspares@groupservice.co.uk
www.vaillant.co.uk

© These instructions, or parts thereof, are protected by copyright and may be reproduced or distributed only with the manufacturer's written consent.