

Grant AERONA³ Air Source Heat Pump Range

Inverter driven heat pumps with outputs from 6kW to 16kW



ErP rating = A++ • MCS approved • DC Inverter driven • Compact size • Base tray heating element
Simple Plumbing and Electrical Connections • Single Phase • 3 models available from 6kW to 16kW



Grant profile

At Grant we have been designing and manufacturing reliable and easy to install heating products for nearly four decades. From award winning oil-fired condensing boilers to the latest renewable technologies, our heating systems have a reputation for quality that is second to none.

We combine precision engineering, innovation, performance and value for money to produce sustainable heating solutions that are trusted by both installers and householders.



Quality Design

There is never a compromise on quality. We design all of our products so that you can be sure that the durability and efficiency are sector leading. We continually develop new technologies and use only the best materials to ensure our products meet all performance and environmental standards.

Our belief in simple solutions ensures that, while our technology is sophisticated, our products are low maintenance and easy to install. For a high quality, reliable and sustainable heating system, trust in Grant.

Heating Responsibly

Grant manufacture heating products that respond to the challenges of rising fuel costs whilst protecting our environment. Environmental responsibility is central to all we do and we continue to develop and innovate to produce even more efficient products that make best use of our natural resources.

We are passionate about developing sustainable, high-performance and affordable alternatives for heating homes into the future.

Our Guarantee

The Grant label is a guarantee of reliability, quality and value. We put our customers first and our independence ensures that we can monitor our standards and processes to deliver the very best quality and service.

That's why, when you order your system from a Grant stockist, you can be sure of a tailored service and excellent aftersales support.

Heat Pump Technology



What are Air Source Heat Pumps?

Air source heat pumps use basic thermodynamic principles to convert thermal energy contained within the air we breathe into heat energy that can be used to provide heating and hot water. This 'ambient heat' is replenished by the sun making our heat pumps both effective and environmentally friendly.

How Heat Pumps Work

There are two basic types of air source heat pump - 'air to air' and 'air to water'. Grant Aerona heat pumps use an air to water system which utilises heat energy captured from the air in 'wet' heating system radiators or underfloor heating.

The process uses the same vapour/compression cycle that extracts heat in a domestic fridge. A refrigerant with a low boiling point is exposed to external air temperatures in an evaporator. The liquid boils off to a gas and absorbs the thermal energy of the air. This gas is then compressed increasing the heat energy contained within the refrigerant, before passing through a heat exchanger where it condenses back to a liquid form, whilst transferring the heat to the water of the heating system. The liquid refrigerant is then re-circulated through the evaporator and the cycle is repeated.

Fit for the Future

With the recent fluctuations in price and supply of fossil fuels, air source heat pumps offer both an environmentally and economically sustainable alternative. Home heating accounts for approximately 30% of CO₂ emissions. The heat source used by Grant Aerona³ heat pumps is entirely renewable which helps reduce the amount of harmful greenhouse gases being released into the atmosphere and, in so doing, lowers the carbon footprint of the household.

Lower Heating Costs

Compared with other domestic heating methods, the Grant Aerona can benefit homeowners by creating annual savings on fuel bills. The units can deliver over four times the amount of energy for every 1kW of electricity used depending on the flow temperature and the climate conditions prevailing at the time. Homes utilising this type of heat generator will obviously have a lower dependency on fossil fuels, making them less susceptible to rising fuel costs.

Grant Aeronas³ Range



Introducing the Aeronas³

The Aeronas³ air source heat pump from Grant provides a cost effective renewable alternative to traditional off-gas heating methods.

Providing both heating and hot water for the property, this innovative range features units with greater operating efficiencies at lower external temperatures, larger outputs to match the type of properties encountered and reduced noise levels when working.

These ground breaking inverter driven heat pumps have a superior SCOP even when external temperatures drop as low as -20°C. Three single phase models are available in 6kW, 10kW and 16kW outputs.

Features

- MCS approved
- R410a refrigerant
- DC inverter driven
- DC fan motor
- DC pump
- DC twin rotary compressor
- In-built weather compensation
- Base tray heating element
- Simple plumbing and electrical connections
- High efficiency plate heat exchanger



Seasonal Efficiency

Seasonal Coefficient of Performance (SCOP)

The SCOP is the overall performance of the heat pump when used in a designated heating season (warm, average or cold), calculated as the reference annual heating demand divided by the annual energy consumed.

Testing is carried out to European and British Standard BS EN 14825 establishing the seasonal space heating energy efficiency and SCOP at various ambient temperatures and system flow temperatures. For example, the Grant Aeronas³ HPID6 model produces 6kW at an SCOP of over 4 when tested at low temperature and average climate conditions. This means for every kilowatt (kW) of energy used to run the Aeronas³, over 4kW of energy is being given to the heating system in return.

It is important to note that as the outside air gets colder, the output and therefore the SCOP of an air source heat pump falls slightly, due to the reduced amount of heat energy available from the air. Conversely, when outside air temperature gets warmer, the output and COP will increase. By using SCOP as opposed to COP, these peaks and troughs are evened out into a realistic annual coefficient.

The overriding factor of the new Aeronas³ heat pump is that the output will modulate down or up depending on the climate conditions and the demand on the heating system giving you peace of mind that you are as energy efficient as you can possibly be on every day of the year.

Seasonal Efficiency at Average Climate Conditions

6kW Aeronas ³	
Flow Temperature	SCOP
35°C	4.34
36°C	4.28
37°C	4.22
38°C	4.16
39°C	4.10
40°C	4.04
41°C	3.99
42°C	3.93
43°C	3.87
44°C	3.81
45°C	3.75
46°C	3.69
47°C	3.63
48°C	3.57
49°C	3.51
50°C	3.45
51°C	3.39
52°C	3.33
53°C	3.27
54°C	3.21
55°C	3.15

10kW Aeronas ³	
Flow Temperature	SCOP
35°C	4.35
36°C	4.30
37°C	4.24
38°C	4.18
39°C	4.12
40°C	4.06
41°C	4.00
42°C	3.94
43°C	3.88
44°C	3.82
45°C	3.77
46°C	3.70
47°C	3.64
48°C	3.58
49°C	3.52
50°C	3.46
51°C	3.40
52°C	3.34
53°C	3.27
54°C	3.21
55°C	3.15

16kW Aeronas ³	
Flow Temperature	SCOP
35°C	4.19
36°C	4.14
37°C	4.09
38°C	4.05
39°C	4.00
40°C	3.95
41°C	3.91
42°C	3.86
43°C	3.82
44°C	3.77
45°C	3.72
46°C	3.67
47°C	3.61
48°C	3.55
49°C	3.50
50°C	3.44
51°C	3.38
52°C	3.32
53°C	3.27
54°C	3.21
55°C	3.15

Technical Specification

HPID6

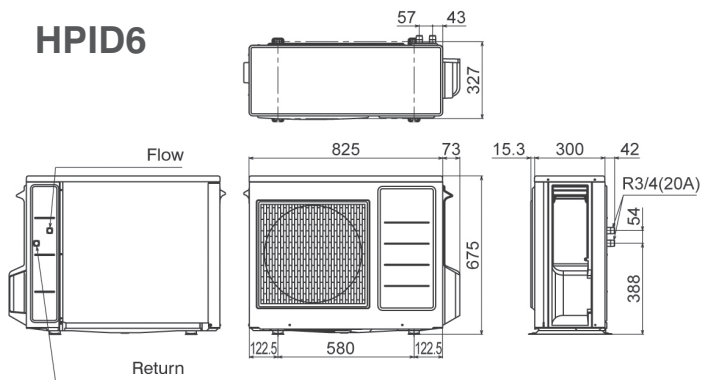

HPID10

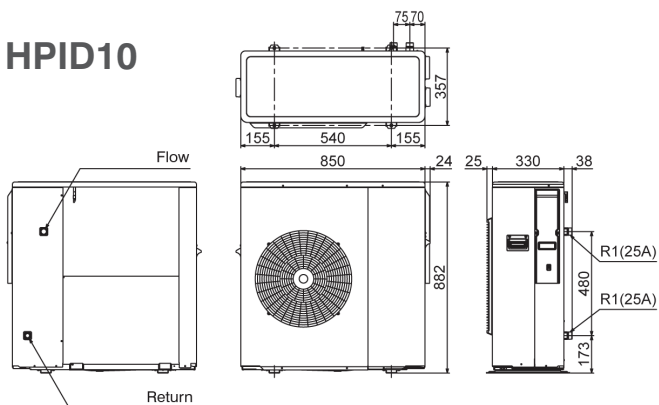

HPID16

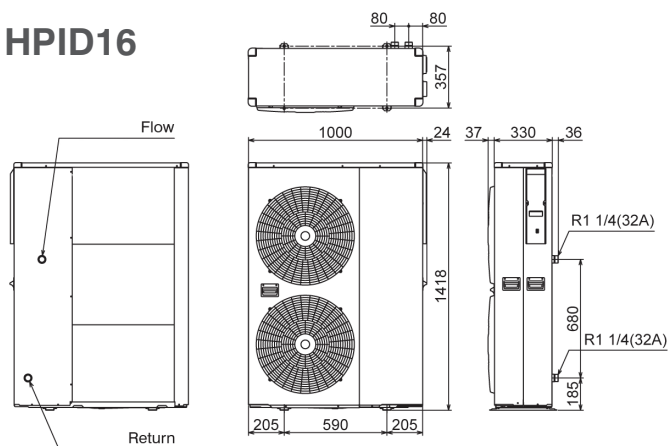

Technical Specifications

Model		HPID6	HPID10	HPID16
ErP Rating	Heating	A++	A++	A++
	Hot Water*	A	A	A
Height (mm)		675	882	1418
Width (mm)		825	850	1000
Depth (mm)		300	330	330
Weight (kg)	Empty	53	75	121
	Full	57	79	126
Capacity (kW)		6.0	10.0	16.0
Power input (kW)		1.46	2.30	3.90
Running current (Max) (A)		6.4 (11.2)	10.2 (17.5)	17.0 (25.3)
COP		4.11	4.25	4.10
Refrigerant (R410A) (kg)		1.05	1.72	2.99
Operating voltage (v)		230	230	230
Flow/ return tappings (BSPF)		3/4"	1"	1 1/4"
Min/max operating temperatures - Air (°C)		-20/43	-20/43	-20/43
Sound power level at 1m (dB(A))**		63	67	63
Sound pressure level at 1m (dB(A))**		37	44	37

* When fitted with a Grant MonoWave HP 200ltr cylinder

** In accordance with BSENISO3744:1995

ErP Heating & Hot Water Packages



Improving your ErP rating

Under the ErP directive, when installing additional heating technologies alongside your heat pump a 'package label' is needed. This details the overall system efficiency rating. It does not apply if you are only installing a heat pump with a hot water cylinder, as this combination is not seen as a 'package' under the Directive.

By combining additional technologies such as solar and controls, you can actually improve the overall package efficiency. Each product would effectively add an efficiency percentage to the heat pump's seasonal space heating ErP rating.

For example, a 10kW Aerona³ (featuring integral weather compensation and controls) with a Grant DuoWave 300 litre heat pump cylinder and a two collector on-roof Sahara solar thermal kit, can achieve an ErP package rating of A++.



Example package label

Guarantees

Grant Aeronas³ air source heat pumps are guaranteed for one year from date of purchase, two years if the product is registered within 30 days (excluding consumable items), subject to being serviced annually and installed in accordance with the manufacturer's instructions. On completion of the installation the heat pump must be commissioned and the online guarantee registration submitted to Grant Engineering Ireland ULC.

Aftersales Service

For peace of mind, all Grant Aeronas³ heat pumps are backed by Grant's comprehensive service operation and in the unlikely event of a problem occurring, your installer should telephone our Customer Service Department on: **+353 (0)579120089**

Heat Pump Cylinders

Grant stainless steel heat pump cylinders are specifically matched to the Aeronas³ range and incorporate a larger primary coil for quicker heat transference.

The cylinders are available in seven indirect single coil versions, ranging from 125-400 litres and five indirect twin coil versions ranging from 170-400 litres. They feature compression fittings which are conveniently located to make installation quicker and easier. For more information and sizes, visit our website: www.grantengineering.ie

Approvals

Grant Aeronas³ heat pumps are manufactured using CE approved components. To ensure performance standards, the units have been tested and approved in a UK test house to BS EN 14511 and EN14825.

Installation and Maintenance

The installation of a Grant Aeronas³ heat pump should be carried out by a Grant G-One Accredited Heat Pump Installer.

Servicing should be carried out annually by a qualified heating engineer. During servicing it is important for the engineer to ensure that the evaporator matrix is clear of debris as any build up could significantly affect the performance of the heat pump.

Magnetic Central Heating Filter

The MagOne (Part code: VM01) provides innovative protection for your Grant Aeronas³ Air Source Heat Pumps. Using a simple to install, triple action filtration design, the MagOne filters magnetite and non-ferrous debris from central heating systems with a 12000 gauss neodymium magnet.

This leaflet is accurate at the time of printing but as Grant UK has a policy of continual improvement it may be superseded. We reserve the right to amend specifications without prior notice. The statutory rights of the consumer are not affected.

All products manufactured under I.S. EN ISO 9001. Grant UK additionally holds ISO 14001 accreditation.

™THE GRANT 'EZ-FIT FLUE' SYSTEM is a trade mark of Grant Engineering Limited.

©Grant Aeronas³, Grant Spira, Grant Vecta, Grant SpiraVac, Grant SpiraPod, Grant Vortex, Grant VortexBlue, Grant VortexAir, Grant Solar, Grant Aurora, Grant Sahara, Grant CombiSOL, Grant WinterSOL, Grant MonoWave, Grant DuoWave, Grant ThermaWave, Euroflame and Multi Pass are registered trade marks of Grant Engineering Limited. The contents of this leaflet are fully protected by copyright and nothing may be reproduced without permission from Grant UK.



Available from Grant Engineering



Grant Condensing Oil Boiler Range



Grant Wood Pellet Boiler Range



Grant Solar Solutions and Cylinders Range



Grant Aeronas³ Air Source Heat Pump Range

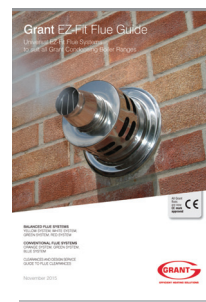

Grant EZ-Fit Flue Systems



Grant Back Boilers



GRANT ENGINEERING IRELAND
Crinkle, Birr, Co. Offaly, Ireland
T: (057) 9120089 F: (057) 9121060
E: info@grant.eu
www.grantengineering.ie

NORTHERN IRELAND
Unit 117, 21 Botanic Avenue
Belfast BT7 1JJ, Northern Ireland
FREEPHONE : 0800 2794796
E: info@grantni.com

