



EFFICIENT HEATING SOLUTIONS

MADE in IRELAND

# Grant Vortex Deisel Condensing Boilers

26kW / 36kW / 46kW

Whisper quiet operation - High efficiency circulating pump - EZ-Fit flue system

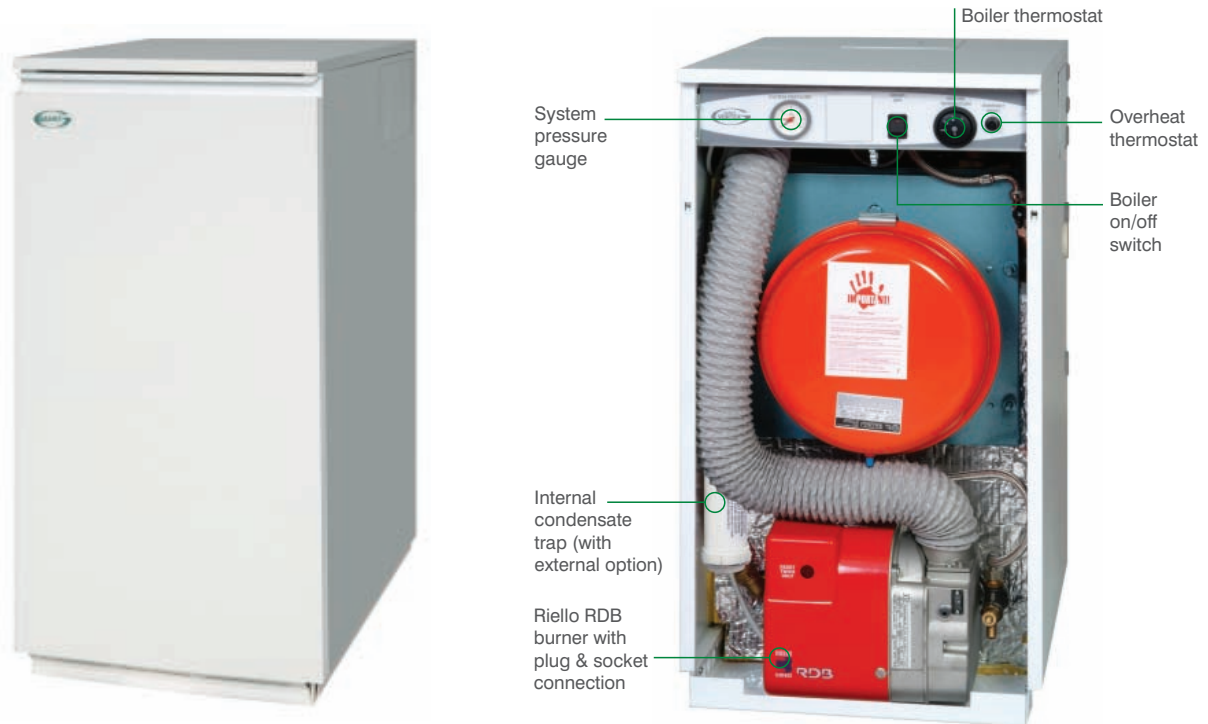

Model shown: DBV26 (front view)

## Technical Specifications

Model	DBV26	DBV36	DBV46
Output kW	15 to 26	26 to 36	36 to 46
Output Btu/h	50-90,000	90-123,000	123-157,000
Efficiency	95%	97%	92.6%
Flow connection	20mm	25mm	25mm
Return connection	20mm	25mm	25mm
Cold water in (system kit)	15mm	15mm	15mm
Pressure relief (system kit)	2.5bar	2.5bar	2.5bar
Weight (dry)	130kg	144kg	150kg
Condensate pipe	21.5mm OD plastic overflow pipe all models		



www.waterware.co.nz  
 info@waterware.co.nz  
 ph +64 9 273 9191



EFFICIENT HEATING SOLUTIONS

MADE in IRELAND

## EZ-Fit White Powder Coated Balanced Flue Sets

- EZ-Fit unique clamping system reduces installation time and costs.
- Top flue sets can be extended to a maximum of 8m.
- Side flue sets can be extended to a maximum of 6m.

### Grant Vortex DBV26

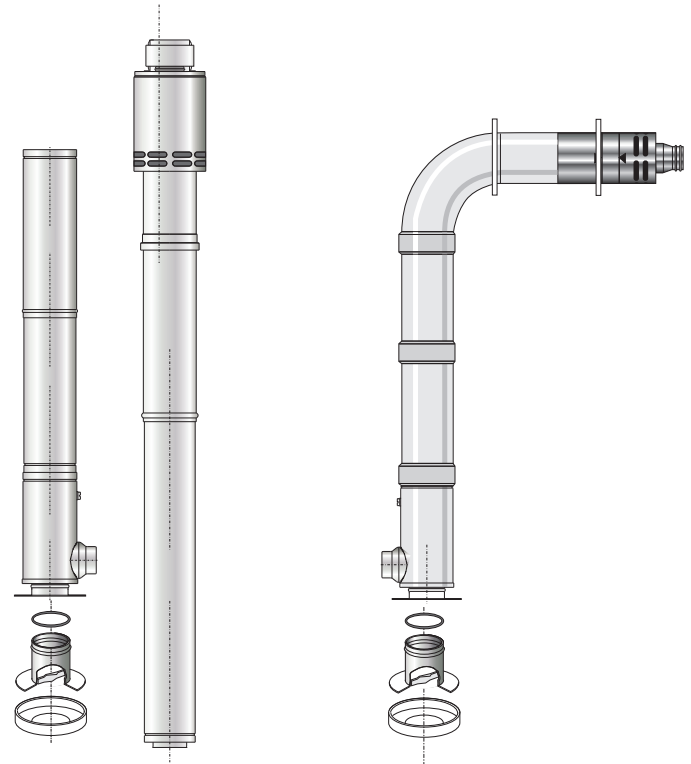
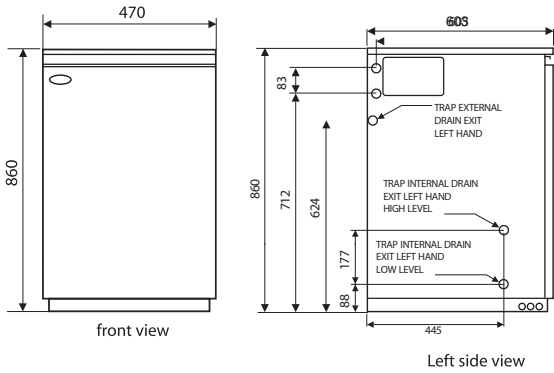

3m Top Flue Set  
DBV26FST (26kW)  
DBV36FST (36 & 46kW)

1.2m High Level Side Flue Set  
DBV26FSS (26kW)  
DBV36FSS (36 & 46kW)

### Grant Vortex DBV26 and DBV36

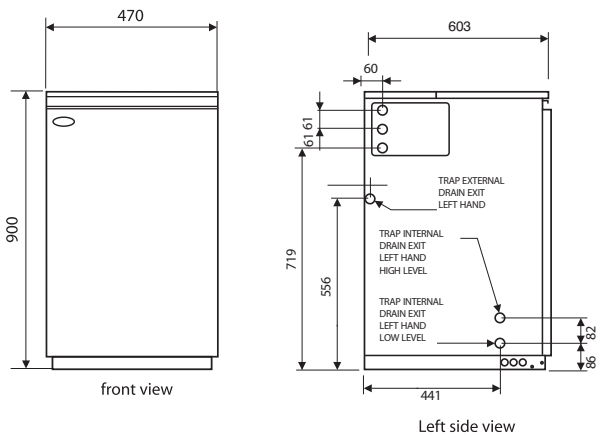

### Grant Vortex DBV46

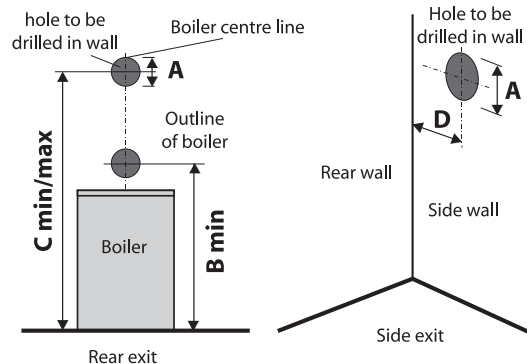
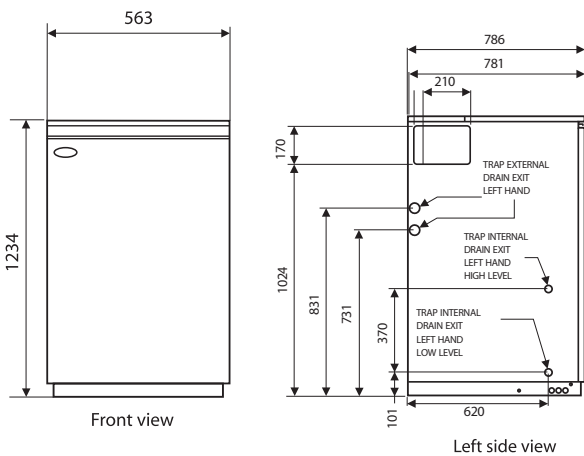

	Flue Ø	A	*Bmin	C min	C max	D
26kW	150	175	1215	1715	2115	115
36 / 46kW	180	200	1280	1700	2020	115

(\*Bmin is with 2 middle telescoping sections removed)