

WATERWARE

# Solar Tempering Valve

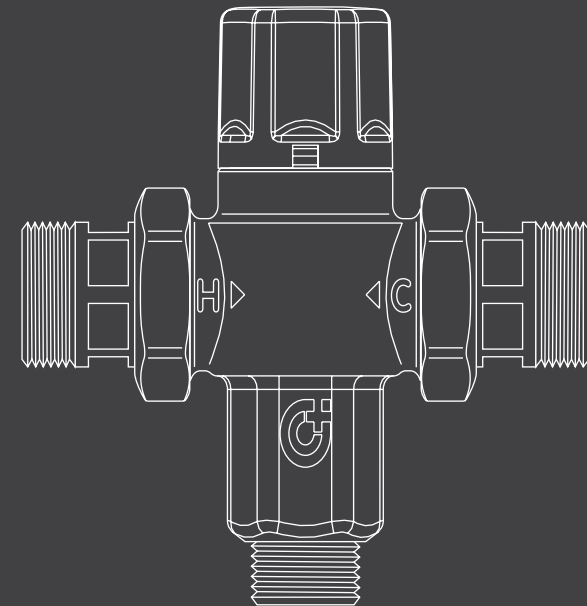

Available in TV252140/150/160  
Technical Installation Manual

PH 09 273 9191 | [info@waterware.co.nz](mailto:info@waterware.co.nz)  
PO Box 58 776 Botany, Manukau  
[waterware.co.nz](http://waterware.co.nz)

## WARRANTY

If any material defect arising from the manufacturing process is found in a new tap or valve Waterware Services Ltd. will undertake to repair or replace it (at its option). This undertaking will not apply if:

1. The defect is brought to Waterware's attention later than 5 years from the date of manufacture.
2. Failure by any person to follow installation instructions or installation in an environment outside the recommended limitations or relevant NZ and or Australian Standards and local plumbing codes. No installation should proceed without installation instructions and claims instructions were missing are not accepted as a means of avoiding this condition.
3. Evidence cannot be produced which confirms that the relevant tap or valve was purchased from a known customer of Waterware Services Ltd.
4. Repair work is undertaken without prior arrangement with Waterware Services Ltd.
5. Normal maintenance requirements, refer to specific product maintenance guides.

Waterware Services Ltd. shall in no way be liable for any loss, damage (direct, indirect or consequential), cost or expense suffered or incurred by the purchaser. Obligations accepted by Waterware Products Ltd. are.....

..... in addition to all other rights and remedies had by the Purchaser in law in respect of the valve and does not limit the right the Consumer may have under the Consumers Guarantee Act 1993.

..... subject to the exceptions and conditions previously listed. All expressed or implied conditions, statements or warranties as to the quality or fitness on any purpose of a tap or valve or otherwise are hereby expressly excluded to the fullest extent permitted by law except under conditions and warrants which cannot be legally excluded by law and which are intended in the contract for the supply of the valve by the Trade Practises and any other Act of Law.

WATERWARE

PH 09 273 9191 | [info@waterware.co.nz](mailto:info@waterware.co.nz)  
PO Box 58 776 Botany, Manukau  
[waterware.co.nz](http://waterware.co.nz)

### Technical data

Approval	UNI EN 12165 CW602N
Quality Assured	ISO9001
Temp Range	30 - 65 °C
Temp Control	+/- 2 °C
Max Op. Temp.	100 °C
Max Op. Press.	1400 kPa
Flow	Rates see graph
Material	DR Brass
Sizes available	15, 20, 25 mm
Check valves	Standard in cold feed, dual hot and cold check valves available in 'C' versions
Min Operating.	Fail-safe *15 °C Temp. differential
*Note the fail-safe feature of this valve conforms to BS1415 as tested at 20 kPa, valve shut off bypass will occur at higher pressures	



### IMPORTANT NOTE:

- Valve is rated for continuous hot water up to a maximum of 100°C. Solar systems operating beyond this temperature will cause irreparable damage not covered by the conditions of warranty.
- Valve is not intended for point of use installations.

### INSTALLATION NOTES

- Installations should firstly conform to any relevant NZ and or Australian Standards and local plumbing codes. The following notes will help to ensure a trouble-free and effective installation.
- Valve should be placed at supply source to prevent untempered hot water bursts from being delivered to the outlet. Consult Waterware Sales for advise on ring main or point of use installations.
- Valve can be installed in vertical or horizontal position (any orientation).
- Hot and cold inlet pressure variations should be kept to a minimum (preferably balanced) for optimum temperature stability.
- Standard valves include a check valve in the cold union for domestic HWC installations. An optional 'C' model valve includes dual hot and cold check valves for special applications.
- The desired temperature should be set after the hot water cylinder has been commissioned and heated. Once set, remove the handle and reposition with the lock tab engaged to prevent tampering.
- Never install a tempering valve in an open vent pipe.
- All supply lines should be protected by a y strainer or similar.
- The valve must not be subjected to extreme temperatures either during installation or in use. In particular, avoid brazing or soldering near the valve.

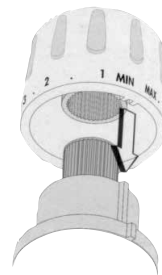

- Before final installation and commissioning the system must be thoroughly flushed out to ensure removal of all debris (See above on Y-Strainers). On older systems, it may be necessary to consider chemical cleaning (descaling) of the system. In known hard water areas, the use of a water softener in the system should be considered to promote ongoing trouble-free operation.

### Maintenance & Testing

Varying degrees of water quality will effect the rate at which scaling or ingression of foreign matter can disable the proper operation of the valve. The valve is designed to inspected and serviced on site if need be. Ensure all surfaces of both the body and control assembly are clean and o-rings lightly lubricated with 'Greasil 4000' or similar. Heat damage is noticeable by deformation of the o-ring profiles and rubber sock over the control element. A maintenance kit including all o-rings and a replacement control element is available if necessary (code: TV522SE).

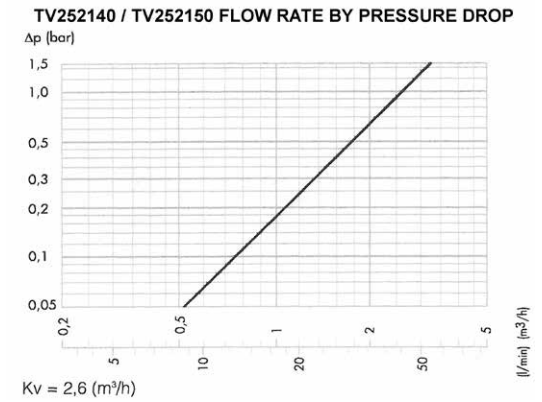

To check performance first ensure HWC storage temperature is not less than 60°C by testing water drained from the TPR valve. Use a bathroom tap to measure with a thermometer the temperature range while cycling the tempering valve control knob from minimum (30°C) to maximum (up to 65°C). Reset the valve to a safe temperature as required by law - Domestic 55°C Commercial 45°C.

### Typical Installations:

#### High Pressure

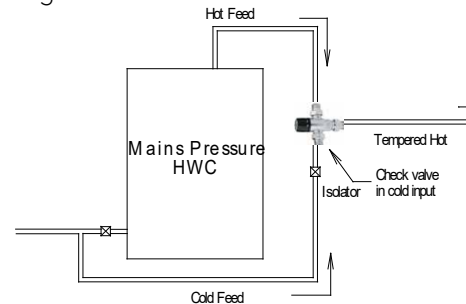

#### Low Pressure

