

## SLIDE SHOWERS

### Installation Limitations

This product is designed for installation in equal high pressure systems only.

- Maximum working pressure 500kPa
- Maximum working temperature 65°C.
- Hot and cold supplies must be protected by line filters

### Installation Procedure *(see diagram over)*

1. Ensure both supply pipes have been flushed and are free from debris before proceeding.
2. Ensure the top and bottom rail mounts are fixed securely to a solid substrate best prepared prior to lining the shower enclosure wall. Follow the assembly diagram according to the model you have purchased. It is recommended a bead of silicon sealant (or equivalent) be laid between the slide rails mounting plates and the surface of the shower wall to prevent any ingress of water.
3. With the rubber gasket in place, hand tighten the 'tapered' nut end of the hose to the hand shower and the other end to the outlet connection. The hose should hang naturally without unnecessary kinks or tight radius bends.
4. Turn water supply on and check carefully all connection points for water tightness.

### Care and Use

1. Shutting the tap gently will reduce the chance of water hammer or 'banging' pipes.
2. Regularly clean the chrome surfaces only with non scouring, neutral wash solutions.



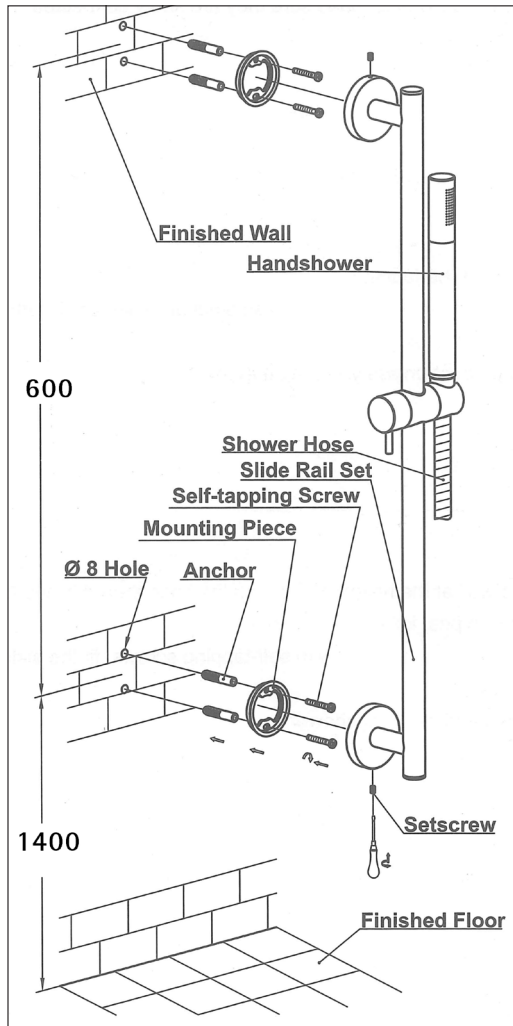

#### **WARRANTY**

If any material defect arising from the manufacturing process is found in a new tap or valve Waterware Services Ltd. will undertake to repair or replace it (at its option). This undertaking will not apply if:

1. The defect is brought to Waterware's attention later than 5 years from the date of manufacture.
2. Failure by any person to follow installation instructions or installation in an environment outside the recommended limitations or relevant NZ and or Australian Standards and local plumbing codes. No installation should proceed without installation instructions and claims instructions were missing are not accepted as a means of avoiding this condition.
3. Evidence cannot be produced which confirms that the relevant tap or valve was purchased from a known customer of Waterware Services Ltd.
4. Repair work is undertaken without prior arrangement with Waterware Services Ltd.
5. Normal maintenance requirements, refer to specific product maintenance guides.

Waterware Services Ltd. shall in no way be liable for any loss, damage (direct, indirect or consequential), cost or expense suffered or incurred by the purchaser. Obligations accepted by Waterware Products Ltd. are.....

..... in addition to all other rights and remedies had by the Purchaser in law in respect of the valve and does not limit the right the Consumer may have under the Consumers Guarantee Act 1993.

..... subject to the exceptions and conditions previously listed. All expressed or implied conditions, statements or warranties as to the quality or fitness on any purpose of a tap or valve or otherwise are hereby expressly excluded to the fullest extent permitted by law except under conditions and warrants which cannot be legally excluded by law and which are intended in the contract for the supply of the valve by the Trade Practises and any other Act of Law.