

- en Operating instructions
- en Installation and maintenance instructions



uniTOWER plus

VIH QW 190/6 E

Publisher/manufacturer

Vaillant GmbH

Berghauser Str. 40 ■ D-42859 Remscheid
Tel. +492191 18 0 ■ Fax +492191 18 2810
info@vaillant.de ■ www.vaillant.de



en	Operating instructions	1
en	Installation and maintenance instructions.....	12

Operating instructions

Contents

1	Safety	2
1.1	Action-related warnings	2
1.2	Intended use	2
1.3	General safety information	2
2	Notes on the documentation	4
3	Product description	4
3.1	Heat pump system	4
3.2	Product design	4
3.3	Opening the front flap	4
3.4	Control elements	4
3.5	Control panel	5
3.6	Description of the symbols	5
3.7	Functional description of buttons	5
3.8	Type designation and serial number	6
3.9	CE marking	6
3.10	Safety devices	6
4	Operation	6
4.1	Basic display	6
4.2	Operating concept	6
4.3	Menu display	6
4.4	Starting up the product	7
4.5	Setting the heating flow temperature	8
4.6	Setting the domestic hot water temperature	8
4.7	Switching off the product's functions	8
5	Care and maintenance	8
5.1	Caring for the product	8
5.2	Maintenance	8
5.3	Reading maintenance messages	8
5.4	Checking the system pressure	8
6	Troubleshooting	9
6.1	Reading fault messages	9
6.2	Detecting and eliminating faults	9
7	Decommissioning	9
7.1	Temporarily decommissioning the product	9
7.2	Permanently decommissioning the product	9
8	Recycling and disposal	9
9	Guarantee and customer service	9
9.1	Guarantee	9
9.2	Customer service	9
Appendix	10
A	Troubleshooting	10
B	Overview of the end user operating level	10



1 Safety

1 Safety

1.1 Action-related warnings

Classification of action-related warnings

The action-related warnings are classified in accordance with the severity of the possible danger using the following warning signs and signal words:

Warning symbols and signal words

**Danger!**

Imminent danger to life or risk of severe personal injury

**Danger!**

Risk of death from electric shock

**Warning.**

Risk of minor personal injury

**Caution.**

Risk of material or environmental damage

1.2 Intended use

There is a risk of injury or death to the user or others, or of damage to the product and other property in the event of improper use or use for which it is not intended.

This product is a system component for controlling the heating circuits and domestic hot water generation in conjunction with a heat pump using a system control.

Intended use includes the following:

- observance of the operating instructions included for the product and any other installation components
- compliance with all inspection and maintenance conditions listed in the instructions.

The product is intended exclusively for domestic use.

The intended use only allows for these product combinations:

Outdoor unit	Indoor unit
VWL ..5/6 A ..	VIH QW 190/6...
	VWZ MEH 97/6

This product can be used by children aged from 8 years and above and persons with reduced physical, sensory or mental capabilities or lack of experience and knowledge if

they have been given supervision or instruction concerning use of the product in a safe way and understand the hazards involved. Children must not play with the product. Cleaning and user maintenance work must not be carried out by children unless they are supervised.

Any other use that is not specified in these instructions, or use beyond that specified in this document, shall be considered improper use. Any direct commercial or industrial use is also deemed to be improper.

Caution.

Improper use of any kind is prohibited.

1.3 General safety information

1.3.1 Danger caused by improper operation

Improper operation may present a danger to you and others, and cause material damage.

- ▶ Carefully read the enclosed instructions and all other applicable documents, particularly the "Safety" section and the warnings.
- ▶ Only carry out the activities for which instructions are provided in these operating instructions.

1.3.2 Risk of death due to changes to the product or the product environment

- ▶ Never remove, bridge or block the safety devices.
- ▶ Do not tamper with any of the safety devices.
- ▶ Do not damage or remove any tamper-proof seals on components.
- ▶ Do not make any changes:
 - The product itself
 - The water and electricity supply lines
 - to the expansion relief valve
 - to the drain pipework
 - to constructional conditions that may affect the operational reliability of the product





1.3.3 Risk of injury and material damage due to maintenance and repairs carried out incorrectly or not carried out at all

- ▶ Never attempt to carry out maintenance work or repairs on your product yourself.
- ▶ Faults and damage should be immediately rectified by a competent person.
- ▶ Adhere to the maintenance intervals specified.

1.3.4 Risk of material damage caused by frost

- ▶ Ensure that the heating installation always remains in operation during freezing conditions and that all rooms are sufficiently heated.
- ▶ If you cannot ensure the operation, have a competent person drain the heating installation.



2 Notes on the documentation

2 Notes on the documentation

- ▶ Always observe all operating instructions that are enclosed with the installation components.
- ▶ Store these instructions and all other applicable documents for further use.

These instructions apply only to:

Product
VIH QW 190/6 (without electric back-up heater)
VIH QW 190/6 E

3 Product description

3.1 Heat pump system

Design of a typical heat pump system with split technology:

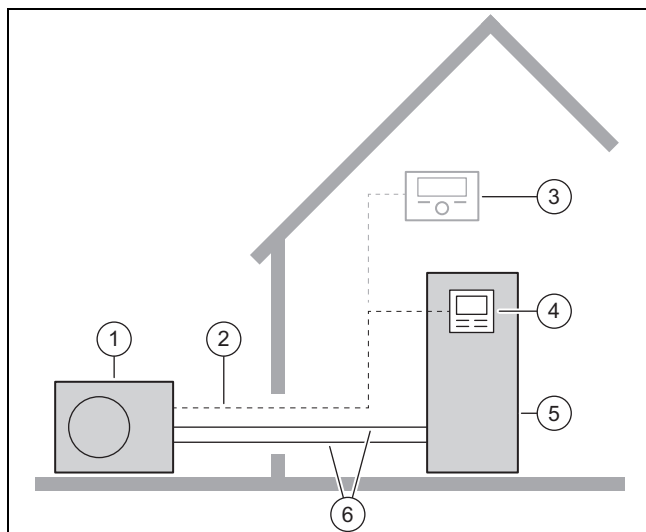

- | | |
|-----------------------------|-------------------------------|
| 1 Heat pump, outdoor unit | 4 Control for the indoor unit |
| 2 eBUS line | 5 Heat pump, indoor unit |
| 3 System control (optional) | 6 Heating circuit |

3.2 Product design

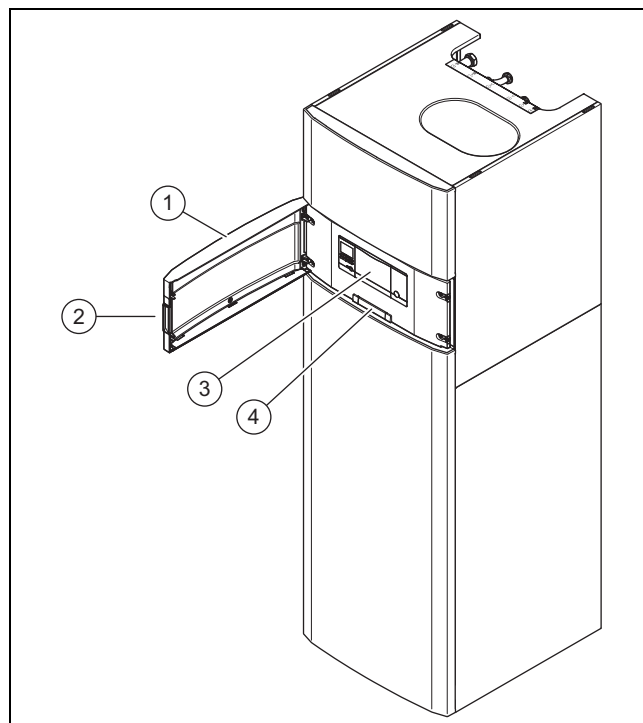

- | | |
|-------------------|--|
| 1 Front flap | 3 Control elements |
| 2 Recessed handle | 4 Plate with serial number on the rear |

3.3 Opening the front flap

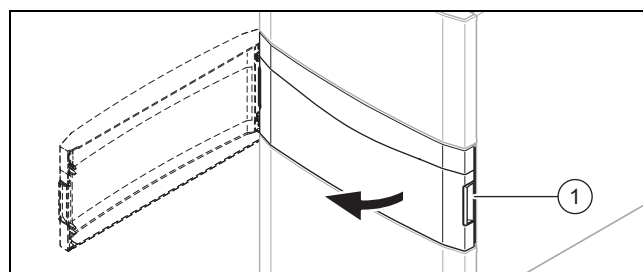

- ▶ Pull the front flap on one of the recessed handles (1) towards you.

3.4 Control elements

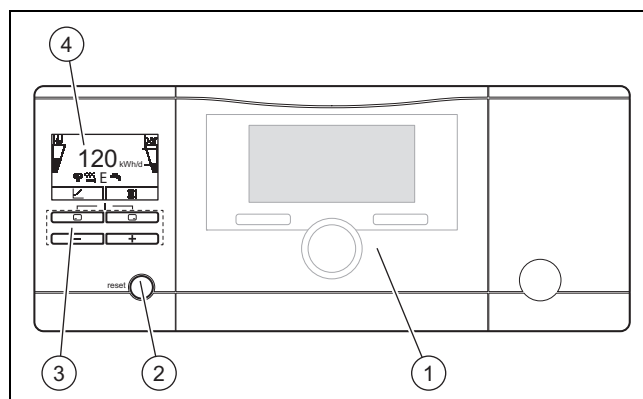

- | | |
|---------------------------------------|-----------------|
| 1 System control (optional accessory) | 3 Control panel |
| 2 Reset button | 4 Display |

3.5 Control panel

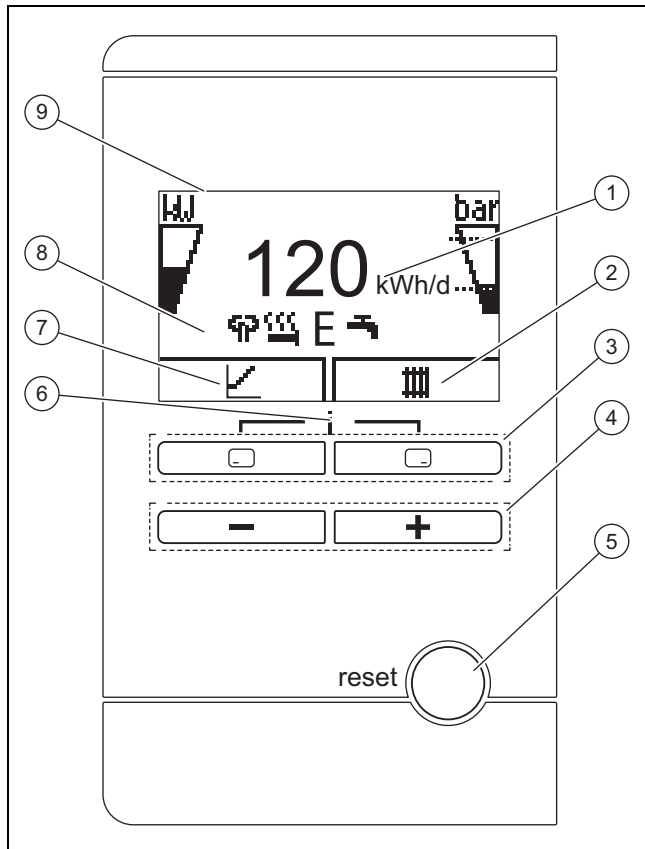

- | | | | |
|---|--|---|---|
| 1 | Displays the daily environmental energy yield | 6 | Access to the menu for additional information |
| 2 | Display of the current right-hand selection button | 7 | Display of the current assignment of the left-hand selection button |
| 3 | Left- and right-hand selection buttons | 8 | Displays the symbols for the heat pump's current operating mode |
| 4 | [-] and [+] button | 9 | Display |
| 5 | Reset button, product restart | | |

3.6 Description of the symbols

If you do not press any buttons within one minute, the light goes out.

Symbol	Meaning	Explanation
	Compressor power	<ul style="list-style-type: none"> - Not filled: Compressor not in operation - Partially filled: Compressor in operation. Partial load mode. - Fully filled: Compressor in operation. Full load mode.





Symbol	Meaning	Explanation
	<ul style="list-style-type: none"> - Without decoupling module - Filling pressure in the building circuit (measured in the outdoor unit) - With decoupling module - Filling pressure in the building circuit (measured in the indoor unit) 	<p>The dashed lines show the permitted range.</p> <ul style="list-style-type: none"> - Displayed statically: Filling pressure in the permitted range - Displayed flashing: Filling pressure outside of the permitted range
	Noise reduction mode	- Operation with reduced sound emissions
	Electric back-up heater	<ul style="list-style-type: none"> - Displayed flashing: Electric back-up heater in operation - Displayed together with the "Heating mode" symbol: Electric back-up heater active for heating mode - Displayed together with the "Domestic hot water generation" symbol: Electric back-up heater active for domestic hot water mode
	eco mode	- Energy-saving domestic hot water mode
	Heating mode	- Heating mode active
	Domestic hot water generation	- Domestic hot water mode active
	Cooling mode	- Cooling mode active
	Fault condition	- Appears instead of the basic display, may be an explanatory plain text display

3.7 Functional description of buttons

The two selection buttons are soft keys, meaning that they can be assigned different functions.

Button	Meaning
	<ul style="list-style-type: none"> - Cancelling the change to a set value or activating an operating mode - Calling up a higher selection level in the menu
	<ul style="list-style-type: none"> - Confirming a set value or activating an operating mode - Calling up a lower selection level in the menu

4 Operation

Button	Meaning
 + 	Calling up the additional functions
 or 	<ul style="list-style-type: none"> - Navigating between individual menu items - Increasing or decreasing the chosen set value

Adjustable values flash in the display.

You must always confirm a change to a value. Only then is the new setting saved. You can press  to cancel a process at any time. If you do not press any buttons for longer than 15 minutes, the display returns to the basic display.

3.8 Type designation and serial number

The type designation and serial number are on the data plate.

3.9 CE marking



The CE marking shows that the products comply with the basic requirements of the applicable directives as stated on the declaration of conformity.

The declaration of conformity can be viewed at the manufacturer's site.

3.10 Safety devices

3.10.1 Frost protection function

The frost protection function for the system is controlled using the product itself or using the optional system control. If the system control fails, the product guarantees limited frost protection for the heating circuit.

At negative outdoor temperatures, there is an increased risk of the heating water freezing if a heat pump fault occurs, e.g. due to a power cut or a defective compressor.

3.10.2 Low-water pressure protection

This function continuously monitors the pressure of the heating water in order to prevent a possible loss of heating water.

3.10.3 Freeze protection

This function prevents the unit's internal heating circuit from freezing when the heating flow temperature drops below a certain value.

If the heating flow temperature of the outdoor unit falls below 4° C, the compressor is switched on in order to increase the heating flow temperature.

3.10.4 Pump blocking protection

This function prevents the pumps for heating water from sticking. The pumps, which were out of operation for 23 hours, are switched on for 10–20 seconds, one after the other.

3.10.5 Safety cut-out (SCO) in the heating circuit

If the temperature in the heating circuit of the internal electric back-up heater exceeds the maximum temperature, the safety cut-out shuts down the electric back-up heater as a

securing measure. After it is triggered, the safety cut-out must be replaced.

- Max. heating circuit temperature: 98 °C

4 Operation

4.1 Basic display

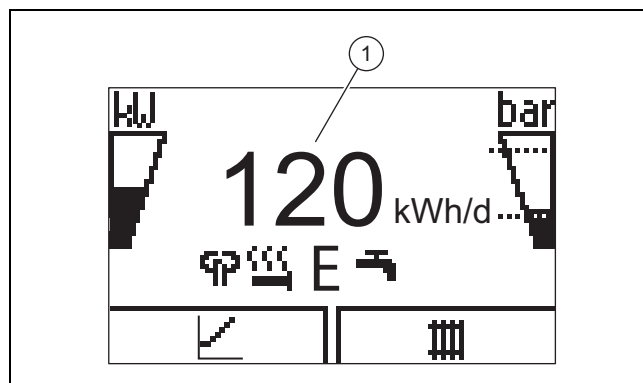

The displays shows the basic display with the current status of the product. The daily energy yield (1) is displayed in the centre of the display.

If you press a selection button, the activated function is displayed in the display.

As soon as a fault message is present, the basic displays switches to the fault message.

4.2 Operating concept

The product has two operating levels.

The operating level for the end user shows the most important information and offers setting options which do not require any special prior knowledge.

The operating level for the competent person is reserved for the competent person and is protected by a code.

Overview of the end user operating level (→ Page 10)

4.3 Menu display

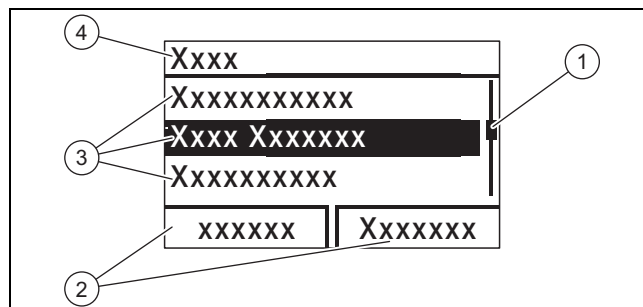

- | | | | |
|---|---|---|------------------------------|
| 1 | Scroll bar | 3 | Selection level list entries |
| 2 | Current assignment of the selection buttons | 4 | Selection level |



Note

Path details at the start of a section specify how to access this function, e.g. **Menu** → **Information** → **Contact data**.

4.4 Starting up the product

4.4.1 Opening the isolator devices

1. Ask the competent person who installed the product to explain to you where these isolator devices are located and how to handle them.
2. If installed, open the service valves in the heating installation's flow and return.
3. Open the cold-water isolation valve.

4.4.2 Switching on the product



Note

The product does not have an on/off switch. The product is switched on and ready for operation as soon as it is connected to the power grid. It can only be switched off using the partition that is installed on-site, e.g. fuses or circuit breaker in the utility connection box.

1. Ensure that the product casing has been installed.
2. Switch on the product via the fuses in the utility connection box.
 - ◁ The "basic display" is shown in the product's operating display.
 - ◁ The "basic display" may also be shown in the display for the optional system control.

4.4.3 Adjusting the target cylinder temperature



Danger!

Risk of death from legionella.

Legionella multiply at temperatures below 60 °C.

- ▶ Have a competent person inform you about the measures that should be taken to protect against Legionella in your installation.
- ▶ Do not set any water temperatures below 60 °C without consulting the competent person first.

Depending on the source of the energy obtained from the environment, target cylinder temperatures of up to 70 °C can be reached with the compressor. In order to achieve energy-efficient domestic hot water generation predominantly from the energy extracted from the environment, the factory setting for the desired domestic hot water temperature must be adjusted on the optional system control and/or on the heat pump's control panel.

Condition: System control connected

- ▶ To do this, adjust the target cylinder temperature (**Desired DHW circuit temperature**) to between 50 and 55 °C.
- ▶ Also switch on the electric back-up heater for the domestic hot water generation so that, also at outdoor temperatures below 0 °C and above 20 °C, the required 60 °C can be achieved for the anti-legionella function time programme.

Condition: No system control connected

- ▶ To do this, adjust the target cylinder temperature (**desired domestic hot water circuit temperature**) to 65 °C.
- ▶ Also switch on the electric back-up heater for the domestic hot water generation so that, at outdoor temperatures below 0 °C and above 20 °C, the required 60 °C can also be achieved for the anti-legionella function.

4.4.4 Yield indicator

You can use this function to display the environmental energy yield as a cumulative value for a period of a day, a month and the total for the heating, domestic hot water generation and cooling modes.

You can displays the working figure for a period of a month and the total for the heating and domestic hot water generation modes. The working figure is the ratio of thermal energy generated to the operating current used. Monthly values may vary considerably since, for example, in the summer only domestic hot water generation is used. A large number of factors influence this estimate, e.g. the type of heating installation (direct heating mode = low flow temperature or indirect heating mode via buffer cylinder = high flow temperature). This figure may therefore deviate by up to 20%.

The working figures only record the power consumption of internal components, not of external components such as external heating circuit pumps, valves, etc.

4.4.5 Displaying the Live Monitor

Menu → Live Monitor

You can use the Live Monitor to view the current status of the product.

4.4.6 Displaying the building circuit pressure

Menu → Live Monitor → Building circuit pressure

You can use this function to display the current filling pressure in the heating installation.

4.4.7 Reading the operating statistics

Menu → Information → Heating op. hours







Menu → Information → DHW operating hours

Menu → Information → Cooling op. hours

Menu → Information → Total operating hours

You can use this function to display the operating hours for heating mode, for domestic hot water mode, for cooling mode and for overall operation.

4.4.8 Setting the language

1. If you want to set another language, press **and hold**  and  **at the same time**.
2. Also press the reset button for a short time.
3. **Press and hold**  and  until the display shows the language setting.
4. Select the required language by pressing  or .
5. Press (OK) to confirm your selection.
6. Once you have set the correct language, press (OK) again to confirm this.

5 Care and maintenance

4.4.9 Set display contrast

Menu → Basic settings → Display contrast

- ▶ You can set the contrast here.

4.4.10 Serial number and article number

Menu → Information → Serial number

The product's serial number is displayed.

The article number is found in the second line of the serial number.



4.4.11 Contact details for the competent person

Menu → Information → Contact data Phone number

If the competent person has entered their telephone number during the installation, you can read it here.

4.5 Setting the heating flow temperature

Condition: No system control connected



- ▶ Press  in the basic display.
- ▶ Use  or  to change the value and confirm this.

Condition: System control connected

- ▶ Set the heating flow temperature on the system control, → System control operating instructions.

4.6 Setting the domestic hot water temperature

Condition: No system control connected

- ▶ Press  in the basic display.
- ▶ Use  or  to change the value and confirm this.



Condition: System control connected

- ▶ Set the domestic hot water temperature on the system control, → System control operating instructions.

4.7 Switching off the product's functions

4.7.1 Switching off heating mode (Summer mode)

Condition: No system control connected



- ▶ Press  in the basic display.
- ▶ Use  to change the value to zero and confirm this.

Condition: System control connected

- ▶ Switch off heating mode on the system control (summer mode), → System control operating instructions.

4.7.2 Switching off domestic hot water generation

Condition: No system control connected

- ▶ Press  in the basic display.
- ▶ Use  to set the value to zero and confirm this.

Condition: System control connected

- ▶ Switch off the domestic hot water generation at the system control (→ System control operating instructions).

4.7.3 Draining the heating installation

Another way to protect the heating installation and the product from frost for very long switch-off times is to drain them completely.

- ▶ Consult a competent person about this.

5 Care and maintenance

5.1 Caring for the product

- ▶ Clean the casing with a damp cloth and a little solvent-free soap.
- ▶ Do not use sprays, scouring agents, detergents, solvents or cleaning agents that contain chlorine.

5.2 Maintenance

An annual inspection and biennial maintenance of the product carried out by a competent person is a prerequisite for ensuring that the product is permanently ready and safe for operation, reliable, and has a long service life. The inspection may require maintenance to be carried out earlier, depending on the results.

5.3 Reading maintenance messages

If the  symbol is shown in the display, the product requires maintenance work or the product is in restricted mode (comfort protection). The product is not in fault mode; it continues to operate.

- ▶ Consult a competent person.

Condition: Lhm. 37 is displayed

The product is in Comfort protection mode. The product has detected a permanent fault and continues to run with restricted comfort.

5.4 Checking the system pressure

1. Check the filling pressure of the heating installation every day for a week after initial start-up and maintenance work, and then twice a year.
 - Min. heating circuit operating pressure: ≥ 0.07 MPa (≥ 0.70 bar)
2. Use **Menu Live Monitor Water pressure** to display the filling pressure.
3. Inform your competent person so that they can add heating water and increase the filling pressure and, in event of frequent pressure losses, determine and eliminate the cause of the loss of heating water.

6 Troubleshooting

6.1 Reading fault messages

Fault messages have priority over all other displays and are shown on the display instead of the basic display. If several faults occur at the same time, these are displayed alternately for two seconds each.

Depending on the type of fault, the system can work in limp home mode in order to maintain the heating mode or domestic hot water generation.

F.723 Building circuit: Pressure too low

If the filling pressure falls below the minimum pressure, the heat pump will be switched off automatically.

- ▶ Inform your competent person so that he can top up the heating water.

F.1120 Immersion heater: Phase failure

The product has an internal circuit breaker which switches off the heat pump in the event of short circuits or the failure of one (product with 230 V power supply) or several (product with 400 V power supply) current-carrying phases.

If the electric back-up heater is defective, the anti-legionella function is not always guaranteed.

- ▶ Inform your competent person so that they can eliminate the fault and reset the internal circuit breaker.

6.2 Detecting and eliminating faults

- ▶ If problems occur whilst operating the product, you can carry out certain checks with the aid of the table. Troubleshooting (→ Page 10)
- ▶ If the product is not functioning correctly, even though you have checked the points listed in the table, contact a competent person.

7 Decommissioning

7.1 Temporarily decommissioning the product

- ▶ Use the partition that is installed on-site (e.g. fuses or power switches) to disconnect the product from the power supply.

7.2 Permanently decommissioning the product

- ▶ Have a competent person permanently decommission and dispose of the product.

8 Recycling and disposal

- ▶ The competent person who installed your product is responsible for the disposal of the packaging.



■ If the product is labelled with this mark:

- ▶ In this case, do not dispose of the product with the household waste.
- ▶ Instead, hand in the product to a collection centre for waste electrical or electronic equipment.



■ If the product contains batteries that are labelled with this mark, these batteries may contain substances that are hazardous to human health and the environment.

- ▶ In this case, dispose of the batteries at a collection point for batteries.

9 Guarantee and customer service

9.1 Guarantee

For information on the manufacturer's guarantee, you can write to the contact address that is provided on the back page.

9.2 Customer service

For contact details for our customer service department, you can write to the address that is provided on the back page, or you can visit www.vaillant.com.

Appendix

Appendix

A Troubleshooting

Problem	Possible cause	Remedy
No domestic hot water, heating remains cold; product does not start up	Building power supply switched off	Switch on building power supply
	Domestic hot water or heating set to "off"/domestic hot water temperature or target temperature set too low	Ensure that domestic hot water mode and/or heating mode is activated in the system control. Set the domestic hot water temperature in the system control to the required value.
	Air in the heating installation	Purging the radiators If the problem occurs again: Inform the competent person
Domestic hot water mode without any problems; heating does not start	No heat requirement via the control	Check the timer programme on the control and correct if necessary Check the room temperature and, if required, correct the target room temperature (→ Control operating instructions)

B Overview of the end user operating level

Setting level	Values		Unit	Increment, select	Factory setting	Setting
	Min.	Max.				
Basic display → Right-hand selection button						
Room temperature setpoint *	Current value		°C			
Manual cooling demand*						
Basic display → Left-hand selection button						
Domestic hot water cylinder target temperature*	Current value		°C			
Domestic hot water cylinder actual temperature	Current value		°C			
Yield indicator →						
Energy yield: Day, Heating	Cumulative value		kWh			
Energy yield: Day, Domestic hot water	Cumulative value		kWh			
Energy yield: Day, Cooling	Cumulative value		kWh			
Energy yield: Month, Heating	Cumulative value		kWh			
Working figure: Month, Heating	Cumulative value					
Energy yield: Total, Heating	Cumulative value		kWh			
Working figure: Total, Heating	Cumulative value					
Energy yield: Month, Cooling	Cumulative value		kWh			
SEER, month, cooling	Cumulative value					
Energy yield: Total, Cooling	Cumulative value		kWh			
SEER, total, cooling	Cumulative value					
Energy yield: Month, Domestic hot water	Cumulative value		kWh			
Working figure: Month, Domestic hot water	Cumulative value					
Energy yield: Total, Domestic hot water	Cumulative value		kWh			
Working figure: Total, Domestic hot water	Cumulative value					
Total energy consumption	Cumulative value		kWh			
Live Monitor →						
Current status message(s)	Current value					
*If no system control is installed, the menu item is displayed in the product's control panel.						

Setting level	Values		Unit	Increment, select	Factory setting	Setting
	Min.	Max.				
Building circuit water pressure	Current value		bar			
Building circuit flow rate	Current value		l/h			
Compressor anti-cycling time	Current value		min			
Immersion heater anti-cycling time	Current value		min			
Target flow temp.	Current value		°C			
Current flow temp.	Current value		°C			
Energy integral	Current value		°min			
Cooling capacity	Current value		kW			
Electrical power consumption	Current value		kW	Total power consumption of the heat pump without any external components connected (as supplied).		
Compressor modulation	Current value		%			
Air inlet temperature	Current value		°C			
Immersion heater power	Current value		kW			
External current anode status	Current value				Anode not connected	
Outdoor temperature	Current value		°C			
Information →						
Contact details	Phone number					
Serial number	Permanent value					
Operating hours total	Cumulative value		h			
Hours heating	Cumulative value		h			
DHW operating hours	Cumulative value		h			
Cooling op. hours	Cumulative value		h			
Default settings →						
Language	Current language			Languages available for selection	02 English	
Display contrast	Current value			1	25	
	15	40				
Resets →						
No sub-items available						
*If no system control is installed, the menu item is displayed in the product's control panel.						

Contents

Installation and maintenance instructions

Contents

1	Safety	14	6.3	Electrical partition	25
1.1	Action-related warnings	14	6.4	Installing components for the energy supply company lockout function	25
1.2	Intended use	14	6.5	Removing the cover from the power supply PCB	26
1.3	General safety information	14	6.6	Routing the cables in the product	26
1.4	Regulations (directives, laws, standards)	15	6.7	Establishing the power supply, 1~/230V	26
2	Notes on the documentation	16	6.8	Establishing the power supply, 3~/400V	27
2.1	Further information	16	6.9	Installing the system control in the electronics box	27
3	Product description	16	6.10	Opening the electronics box	28
3.1	Heat pump system	16	6.11	Routing the cables in the electronics box	28
3.2	Safety devices	16	6.12	Carrying out the wiring	28
3.3	Functional elements	17	6.13	Connecting the circulation pump	28
3.4	Serial number	17	6.14	Connecting a limit thermostat for the underfloor heating	28
3.5	Information on the data plate	17	6.15	Connecting the outdoor temperature sensor	29
3.6	Connection symbols	17	6.16	Connecting the external prioritising diverter valve (optional)	29
3.7	CE marking	18	6.17	Connecting the VR 70/VR 71 mixer module	29
3.8	Energy balance control	18	6.18	Installing the cover for the power supply PCB	29
3.9	Compressor hysteresis	18	6.19	Checking the electrical installation	29
3.10	Cooling mode	18	7	Operation	29
4	Set-up	18	7.1	Operating concept of the product	29
4.1	Unpacking the product	18	8	Start-up	29
4.2	Checking the scope of delivery	18	8.1	Prioritising diverter valve, setting the heating circuit/cylinder charging	29
4.3	Selecting the installation site	18	8.2	Checking and treating the heating water/filling and supplementary water	29
4.4	Dimensions	19	8.3	Filling and purging the heating installation	30
4.5	Minimum clearances and installation clearances	19	8.4	Filling the domestic hot water circuit	31
4.6	Product dimensions for the transport	19	8.5	Purging	31
4.7	Transporting the product	19	8.6	Switching on the product	31
4.8	Separating the product into two modules where necessary	20	8.7	Running the installation assistants	31
4.9	Removing the casing	21	8.8	Menu functions without the optional system control	32
4.10	Installing the casing	22	8.9	Enabling the electric back-up heater	32
4.11	Moving the electronics box (optional)	23	8.10	Setting the anti-legionella function	32
4.12	Setting up the indoor unit	23	8.11	Calling up the installer level	32
4.13	Removing the carrying straps	23	8.12	Checking the configuration	32
5	Hydraulics installation	23	8.13	Calling up statistics	32
5.1	Carrying out the installation preparations	23	8.14	Displaying the filling pressure in the building circuit	32
5.2	Connecting the heat pump to the indoor unit	24	8.15	Checking function and leak-tightness	33
5.3	Connecting the building circuit	24	8.16	Floor drying	33
5.4	Installing the domestic hot and cold water connection	24	8.17	Starting up the optional system control	33
5.5	Installing potable water pipes	24	9	Adapting the unit to the heating installation	33
5.6	Installing the drain pipe on the expansion relief valve	24	9.1	Configuring the heating installation	33
5.7	Connecting the condensate discharge	24	9.2	Total pressure loss in the product, building circuit	34
5.8	Connecting additional components	25	9.3	Total pressure loss in the product, domestic hot water	34
6	Electrical installation	25	9.4	Instructing the end user	34
6.1	Preparing the electrical installation	25			
6.2	Requirements for the quality of the mains voltage	25			

10	Troubleshooting	34	Index	60
10.1	Contacting your service partner.....	34		
10.2	Reading off the fault codes.....	34		
10.3	Querying the fault memory	34		
10.4	Resetting the fault memory.....	34		
10.5	Displaying Live Monitor (status codes).....	34		
10.6	Using the function menu	34		
10.7	Carrying out the actuator test	35		
10.8	Safety cut-out.....	35		
10.9	Resetting parameters to factory settings	35		
11	Inspection and maintenance	35		
11.1	Procuring spare parts	35		
11.2	Checking maintenance messages.....	35		
11.3	Observing inspection and maintenance intervals	36		
11.4	Preparing for inspection and maintenance	36		
11.5	Using check programmes.....	36		
11.6	Checking the pre-charge pressure of the expansion vessel	36		
11.7	Checking the magnesium protection anode	36		
11.8	Cleaning the domestic hot water cylinder.....	36		
12	Draining	36		
12.1	Draining the product's heating circuit.....	36		
12.2	Draining the product's domestic hot water circuit	37		
13	Decommissioning.....	37		
13.1	Decommissioning the product	37		
14	Recycling and disposal.....	37		
15	Customer service.....	37		
	Appendix	38		
A	Functional diagram.....	38		
B	Wiring diagram.....	39		
C	Control PCB	40		
D	Basic connection diagram for the energy supply company lockout, shutdown via connection S21	41		
E	Basic connection diagram for the energy supply company lockout, shutdown via partition	42		
F	Installer level overview.....	43		
G	Status codes	47		
H	Maintenance messages	49		
I	Comfort protection mode.....	49		
J	Fault codes.....	50		
K	5.4 kW back-up heater at 230 V	54		
L	8.54 kW back-up heater at 400 V	55		
M	Inspection and maintenance work.....	55		
N	Characteristic values for the internal temperature sensors, hydraulic circuit	55		
O	Characteristic values for the VR10 internal temperature sensors, cylinder temperature	56		
P	Characteristic values for the VRC DCF outdoor temperature sensor.....	57		
Q	Technical data.....	57		



1 Safety

1 Safety

1.1 Action-related warnings

Classification of action-related warnings

The action-related warnings are classified in accordance with the severity of the possible danger using the following warning signs and signal words:

Warning symbols and signal words

**Danger!**

Imminent danger to life or risk of severe personal injury

**Danger!**

Risk of death from electric shock

**Warning.**

Risk of minor personal injury

**Caution.**

Risk of material or environmental damage

1.2 Intended use

There is a risk of injury or death to the user or others, or of damage to the product and other property in the event of improper use or use for which it is not intended.

This product is a system component for controlling the heating circuits and domestic hot water generation in conjunction with a heat pump using a system control.

The product is intended exclusively for domestic use.

The intended use only allows for these product combinations:

Outdoor unit	Indoor unit
VWL ..5/6 A ..	VIH QW 190/6...
	VWZ MEH 97/6

Intended use includes the following:

- observance of accompanying operating, installation and maintenance instructions for the product and any other system components
- installing and setting up the product in accordance with the product and system approval
- compliance with all inspection and maintenance conditions listed in the instructions.

Intended use also covers installation in accordance with the IP code.

Any other use that is not specified in these instructions, or use beyond that specified in this document, shall be considered improper use. Any direct commercial or industrial use is also deemed to be improper.

Caution.

Improper use of any kind is prohibited.

1.3 General safety information

1.3.1 Risk caused by inadequate qualifications

The following work must only be carried out by competent persons who are sufficiently qualified to do so:

- Set-up
- Dismantling
- Installation
- Start-up
- Inspection and maintenance
- Repair
- Decommissioning
- ▶ Proceed in accordance with current technology.

1.3.2 Risk of death from electric shock

There is a risk of death from electric shock if you touch live components.

Before commencing work on the product:

- ▶ Disconnect the product from the power supply by switching off all power supplies at all poles (electrical partition with a contact gap of at least 3 mm, e.g. fuse or circuit breaker).
- ▶ Secure against being switched back on again.
- ▶ Wait for at least 3 minutes until the capacitors have discharged.
- ▶ Check that there is no voltage.

1.3.3 Risk of death due to lack of safety devices

The basic diagrams included in this document do not show all safety devices required for correct installation.

- ▶ Install the necessary safety devices in the installation.





- ▶ Observe the applicable national and international laws, standards and directives.

1.3.4 Risk of being burned or scalded by hot components

- ▶ Only carry out work on these components once they have cooled down.

1.3.5 Risk of scalding from hot water

There is a risk of scalding at the hot water draw-off points if the hot water temperatures are greater than 60 °C. Young children and elderly persons are particularly at risk, even at lower temperatures.

- ▶ Select a moderate set target temperature.
- ▶ Inform the operator about the risk of scalding when the **Anti-legionella** function is switched on.

1.3.6 Risk of injury due to the heavy weight of the product

The product weighs over 50 kg.

- ▶ Make sure that the product is carried by at least two people.
- ▶ Use suitable transport and lifting equipment, in accordance with your risk assessment.
- ▶ Use suitable personal protective equipment: Gloves, safety footwear, protective goggles, protective helmet.

1.3.7 Material damage due to unsuitable installation surface

The installation surface must be even and have sufficient load-bearing capacity to support the operating weight of the product. An uneven installation surface may cause leaks in the product.

There is a risk of death if the connections are subject to leaks.

- ▶ Make sure that the product is positioned flush against the installation surface.
- ▶ Ensure that the installation surface has sufficient load-bearing capacity to bear the operating weight of the product.

1.3.8 Risk of material damage due to malfunctioning

Not rectifying faults, changing the safety devices and failing to carry out maintenance

can cause malfunctioning and pose safety risks during operation.

- ▶ Ensure that the heating installation is in a technically perfect condition.
- ▶ Ensure that no safety or monitoring devices have been removed, bridged or disabled.
- ▶ Immediately eliminate any faults and damage that may affect safety.

1.3.9 Material damage due to additives in the heating water

Unsuitable antifreeze and corrosion inhibitors may damage seals and other components of the heating circuit, and may therefore also cause water leaks.

- ▶ Only add approved antifreeze and corrosion inhibitors to the heating water.

1.3.10 Risk of material damage caused by frost

- ▶ Do not install the product in rooms prone to frost.

1.3.11 Risk of material damage caused by using an unsuitable tool

- ▶ Use the correct tool.

1.4 Regulations (directives, laws, standards)

- ▶ Observe the national regulations, standards, directives, ordinances and laws.



2 Notes on the documentation

2 Notes on the documentation

- ▶ Always observe all the operating and installation instructions included with the system components.
- ▶ Pass these instructions and all other applicable documents on to the end user.

These instructions apply only to:

Product
VIH QW 190/6 (without electric back-up heater)
VIH QW 190/6 E

2.1 Further information



- ▶ Scan the displayed code using your smartphone in order to view further information about the installation.
 - ◀ You are guided to installation videos.

3 Product description

3.1 Heat pump system

Design of a sample heat pump system with monoblock technology:

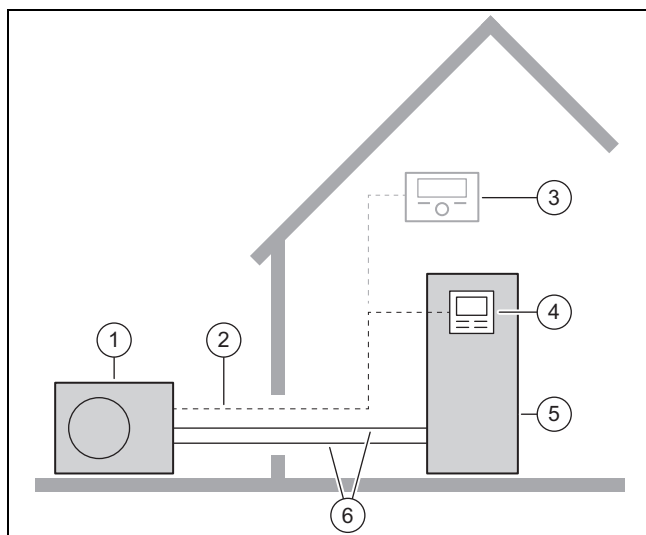

- | | | | |
|---|---------------------------|---|-----------------------------|
| 1 | Heat pump, outdoor unit | 4 | Control for the indoor unit |
| 2 | eBUS line | 5 | Heat pump, indoor unit |
| 3 | System control (optional) | 6 | Heating circuit |

3.2 Safety devices

3.2.1 Frost protection function

The frost protection function for the system is controlled using the product itself or using the optional system control. If the system control fails, the product guarantees limited frost protection for the heating circuit.

At negative outdoor temperatures, there is an increased risk of the heating water freezing if a heat pump fault occurs, e.g. due to a power cut or a defective compressor.

3.2.2 Low-water pressure protection

This function continuously monitors the pressure of the heating water in order to prevent a possible loss of heating water. If the water pressure falls below the minimum pressure, an analogue pressure sensor switches the product off and, if available, switches other modules to standby mode. If the water pressure reaches the operating pressure, the pressure sensor switches the product back on.

If the heating water pressure falls below ≤ 0.1 MPa (1 bar), a maintenance message appears below the display of the minimum operating pressure.

- Min. heating circuit pressure: ≥ 0.05 MPa (≥ 0.50 bar)
- Min. heating circuit operating pressure: ≥ 0.07 MPa (≥ 0.70 bar)

3.2.3 Safety cut-out (SCO) in the heating circuit

If the temperature in the heating circuit of the internal electric back-up heater exceeds the maximum temperature, the safety cut-out shuts down the electric back-up heater as a securing measure. After it is triggered, the safety cut-out must be replaced.

- Max. heating circuit temperature: 98 °C

3.3 Functional elements

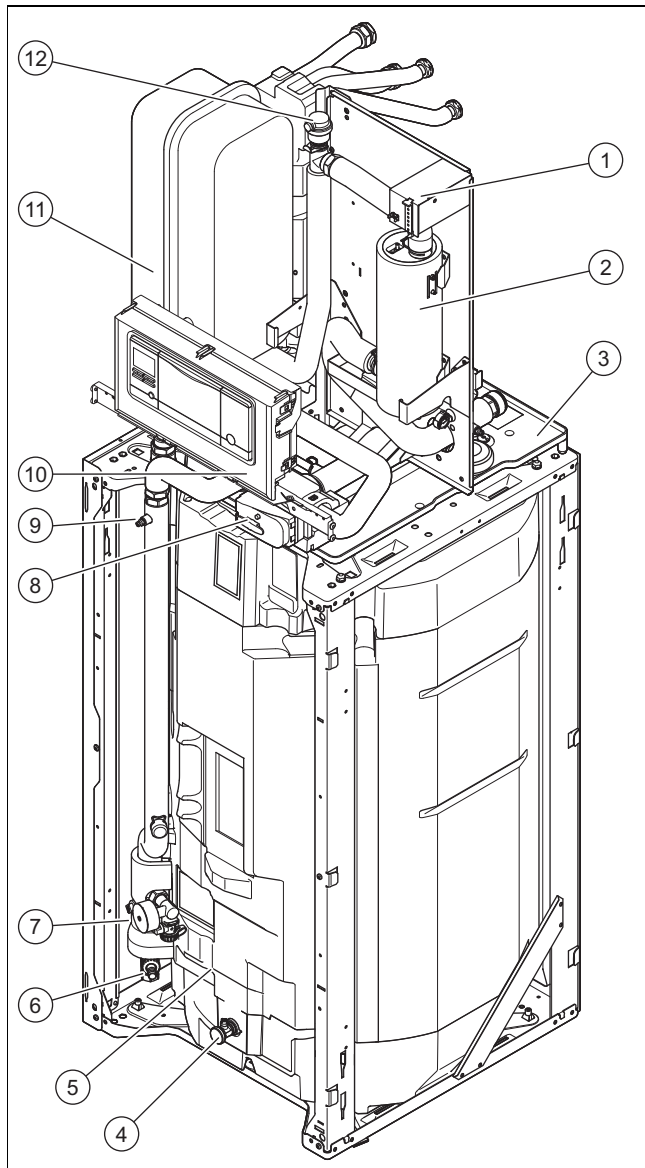

- | | | | |
|---|---|----|-----------------------------|
| 1 | Safety cut-out | 7 | Manometer and filling tap |
| 2 | Back-up heater | 8 | Prioritising diverter valve |
| 3 | Condensate tray | 9 | Purging valve |
| 4 | Draining the domestic hot water cylinder | 10 | Electronics box |
| 5 | Domestic hot water cylinder | 11 | Expansion vessel |
| 6 | Draining cock, heating flow and return draining cock and building circuit | 12 | Automatic air vent |

3.4 Serial number

The serial number can be found on the data plate on the rear of the electronics box.

The serial number may also be shown on the product's display (→ Operating instructions).

3.5 Information on the data plate



The data plate keeps record of the country in which the product is to be installed.

	Information	Meaning
	Serial no.	Unique unit identification number
Nomenclature	VIH	Vaillant indirect domestic hot water cylinder
	QW	Rectangular domestic hot water cylinder
	190	Cylinder volume
	E	With electric back-up heater
	/6	Unit generation
	IP	Protection class
Symbols		Cylinder heating coil
		Control
		Heating circuit
		Cylinder tank, fill quantity, permissible pressure
		Back-up heater
	P max	Rated power, maximum
	P	Rated power
	I max	Rated current, maximum
	I	In-rush current
Heating circuit, domestic hot water circuit	MPa (bar)	Permissible operating pressure
	L	Fill quantity
	CE marking	See section "CE marking"

3.6 Connection symbols

Symbol	Connection
	Building circuit, flow
	Building circuit, return
	Heating flow
	Heating return

4 Set-up

Symbol	Connection
	Domestic hot water circuit, cold water
	Domestic hot water circuit, domestic hot water

3.7 CE marking



The CE marking shows that the products comply with the basic requirements of the applicable directives as stated on the declaration of conformity.

The declaration of conformity can be viewed at the manufacturer's site.

3.8 Energy balance control

The energy balance is the integral from the difference between the flow temperature actual value and target value, which is added up every minute. If the set heat deficit ($WE = -60^\circ\text{min}$ in heating mode) is reached, the heat pump starts. If the supplied heat volume corresponds to the heat deficit (integral = 0°min), the heat pump is switched off.

The energy balancing is used for heating and cooling mode.

3.9 Compressor hysteresis

The heat pump is switched on and off via the compressor hysteresis for heating mode and also for energy balancing. When the compressor hysteresis is above the target flow temperature, the heat pump is switched off. When the hysteresis is below the target flow temperature, the heat pump starts up again.

3.10 Cooling mode

The product is compatible with the heat pump's cooling mode.

- ▶ Activate and parametrise the cooling mode in the system control.

4 Set-up

4.1 Unpacking the product

1. Remove the product packaging.
2. Remove the documentation.
3. Remove the front casing. (→ Page 21)

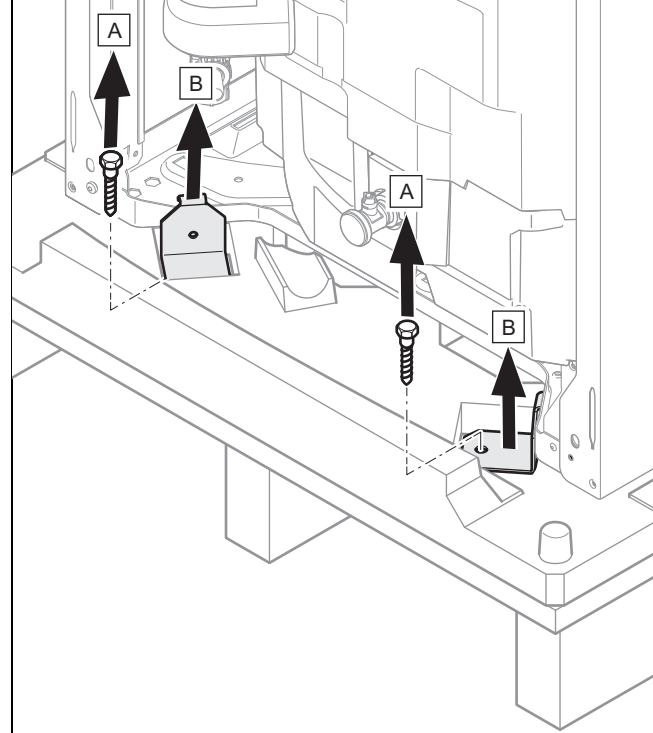

4. Unscrew the four fixing tabs at the front and rear of the pallet and remove them.

4.2 Checking the scope of delivery

- ▶ Check that the scope of delivery is complete and intact.

Quantity	Designation
1	Product
1	Enclosed documentation
1	Bag with installation material
1	Main power supply cable, single-phase, 230 V (3 x 6 mm ²)
1	Main power supply cable, three-phase, 400 V (5 x 1.5 mm ²)

4.3 Selecting the installation site

- ▶ The installation site must be below 2000 metres above sea level.
- ▶ Select a dry room that is frost-proof throughout and in which the maximum installation height is not exceeded and the environmental temperature is neither above nor below the permitted range.
 - Permissible environmental temperature: 7 to 40 °C
 - Permissible relative air humidity: 40 to 75 %
- ▶ Ensure that the required minimum clearances can be maintained.
- ▶ The permissible height difference between the indoor unit and outdoor unit must not be greater than 15 m.

- ▶ When selecting the installation site, you must take into consideration that, when the product is in operation, it transfers vibrations to the floor and the nearby walls.
- ▶ Ensure that the floor is even and offers sufficient load-bearing capacity to bear the weight of the product.
- ▶ Ensure that the pipes are routed appropriately.

4.4 Dimensions

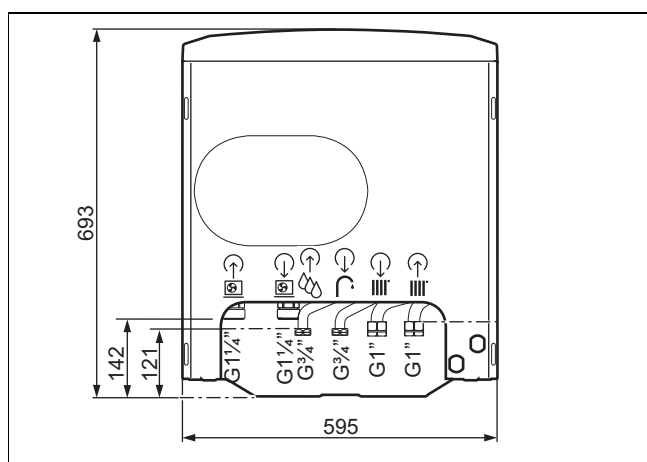
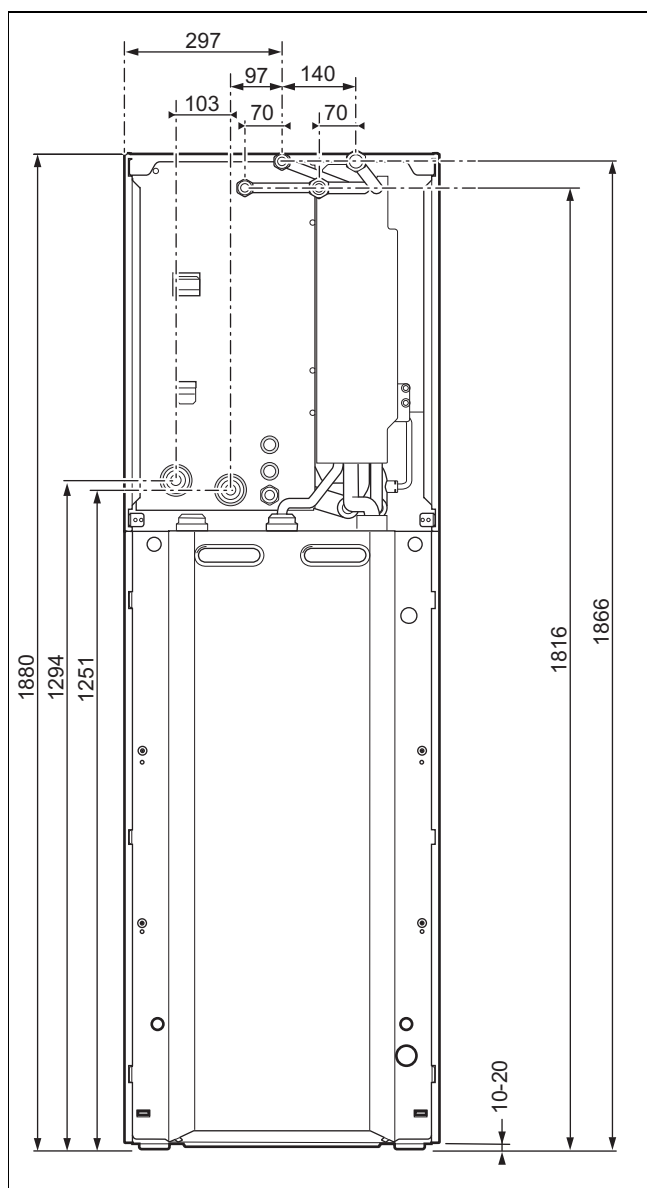

4.5 Minimum clearances and installation clearances

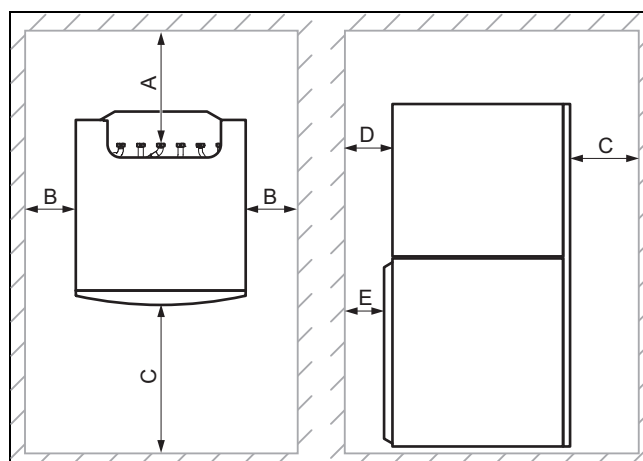

A	130 mm	D	40 mm
B	300 mm	E	10 mm
C	600 mm		

- ▶ Provide sufficient clearance (**B**) on at least one side of the product in order to facilitate access for maintenance and repair work.
- ▶ When using the accessories, observe the minimum clearances/installation clearances.

4.6 Product dimensions for the transport

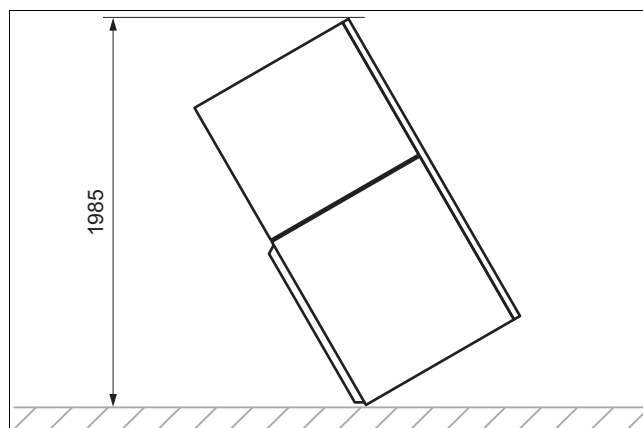

4.7 Transporting the product



Danger!
Risk of injury due to carrying heavy loads.
 Carrying heavy loads can cause injuries.

- ▶ When transporting heavy products, observe all valid laws and other regulations.

1. If the spatial conditions do not allow for the unit to be inserted as a whole, separate the product into two modules. (→ Page 20)
2. Transport the product to the installation site. Use the recessed handles on the rear and the carrying straps at the front on the underside of the product as an aid.

4 Set-up

4.7.1 Using the carrying straps

1. Remove the front casing. (→ Page 21)



Danger!
Risk of injury due to repeated use of the carrying straps.

Due to material ageing, the carrying straps are not designed to be reused during any subsequent transportation.

- ▶ Once the product has been started up, cut off the carrying straps.



Caution.
Risk of damage caused by carrying straps.

The carrying straps may damage the front casing during transport.

- ▶ Remove the front casing before you use the carrying straps.

2. To transport the unit safely, use the two carrying straps on the two front feet of the product.

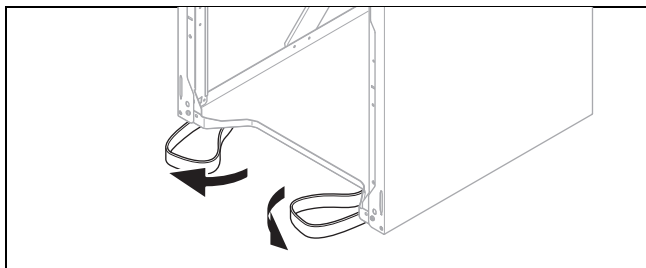

3. If the carrying straps are located underneath the product, swivel these to the front.

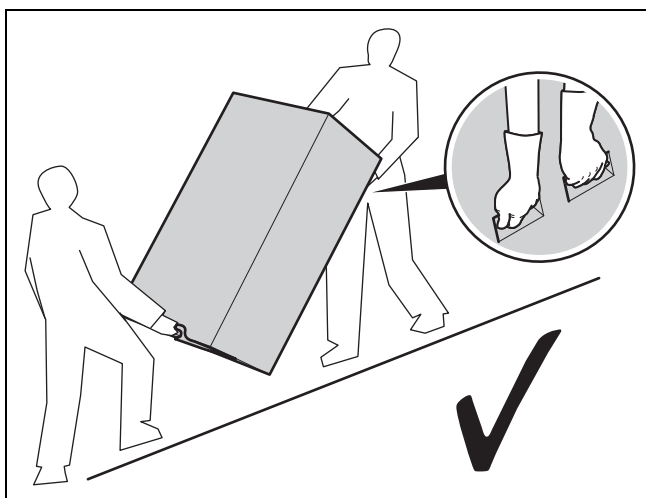

4. Always transport the lower part of the product as shown above.

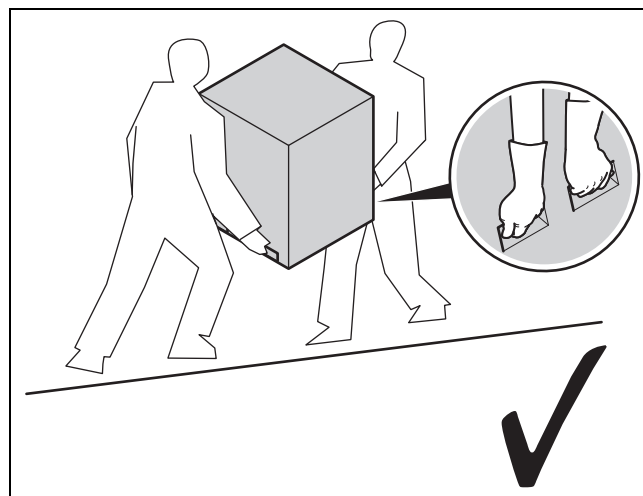

5. Always transport the upper part of the product as shown above.

4.8 Separating the product into two modules where necessary

1. Remove the front casing. (→ Page 21)
2. Remove the side casing. (→ Page 21)
3. Move the electronics box into the maintenance position. (→ Page 23)

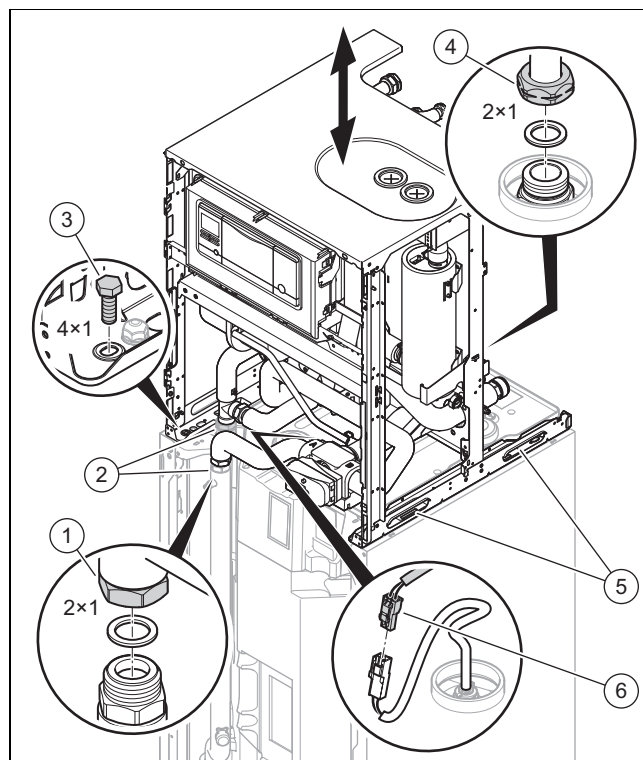

4. Slide the heat insulation (2) on the pipe transitions upwards.
5. Unscrew the two nuts (1) on the pipe connections.
6. Disconnect the plug connection for the cylinder temperature sensor (6).
7. Remove the four screws (3).
8. Unscrew the two nuts (4) on the pipe connections.
9. Use the recessed handles (5) to lift off the upper part of the product.
10. To assemble the product, carry out the steps described above in reverse order.

4.9 Removing the casing

4.9.1 Removing the front casing

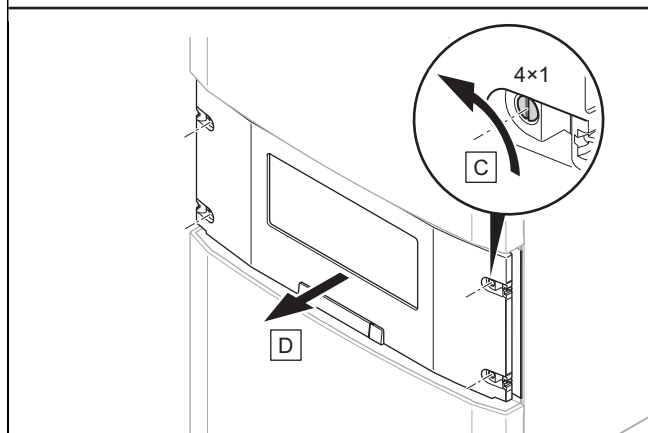
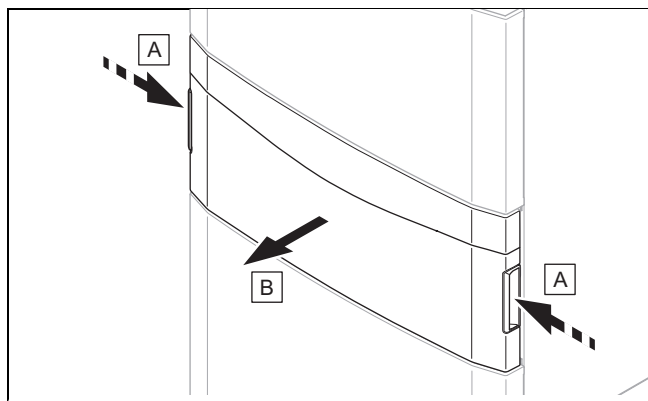

1. Remove the front flap on the control panel by taking hold of the recessed handles with both hands and lifting off the front flap towards you.
2. Turn the four screws by a quarter turn and lift off the cover on the control panel towards you.

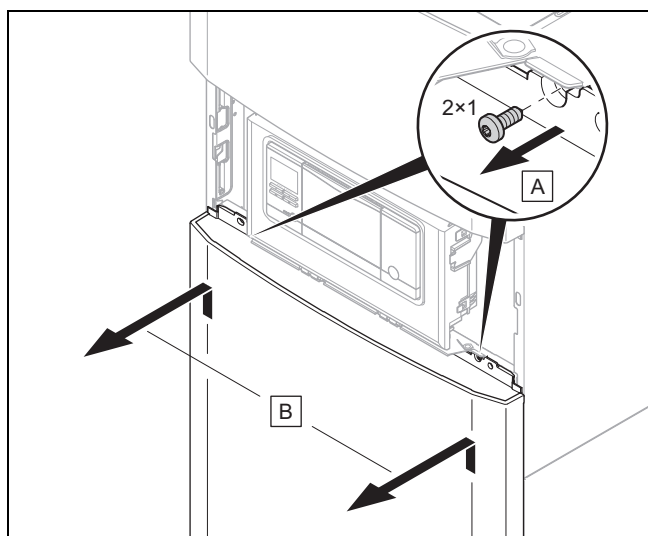

3. Remove both screws, raise the lower section of the front casing and pull it forwards and out.

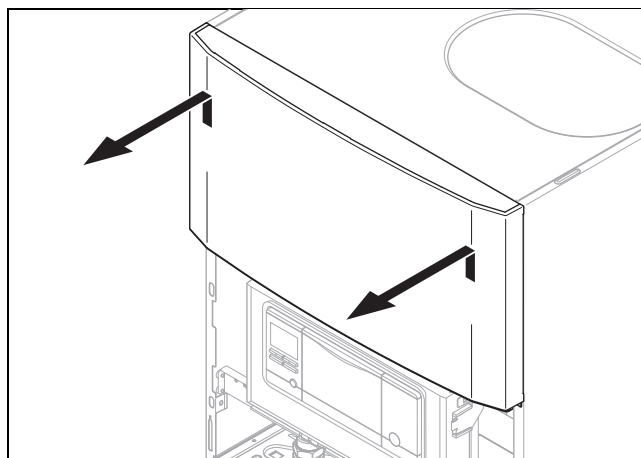

4. Lift the upper section of the front casing upwards and out.

4.9.2 Removing the side casing

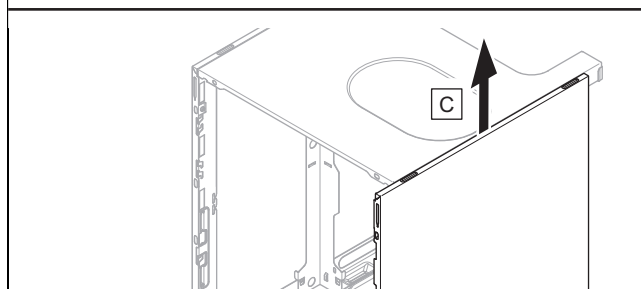
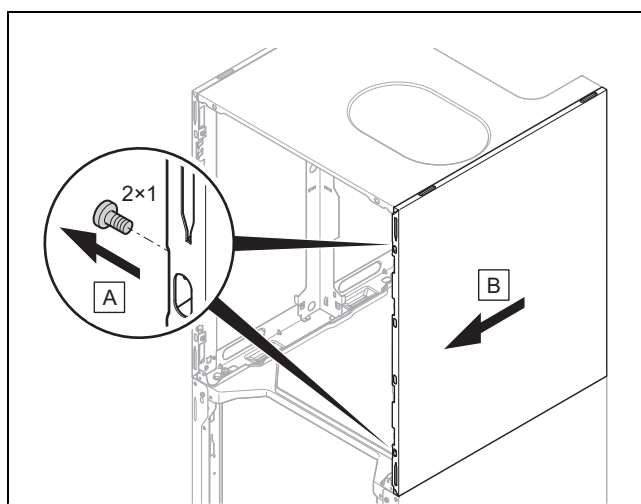

- Remove the side casing as shown in the figure.

4 Set-up

4.10 Installing the casing

4.10.1 Installing the front casing

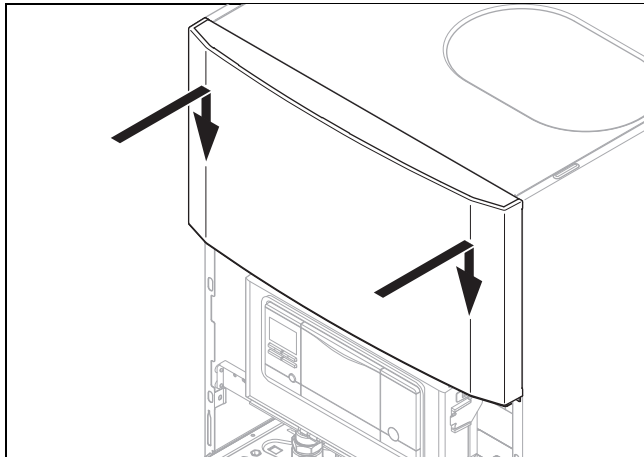

1. Install the upper part of the front casing as shown in the figure.

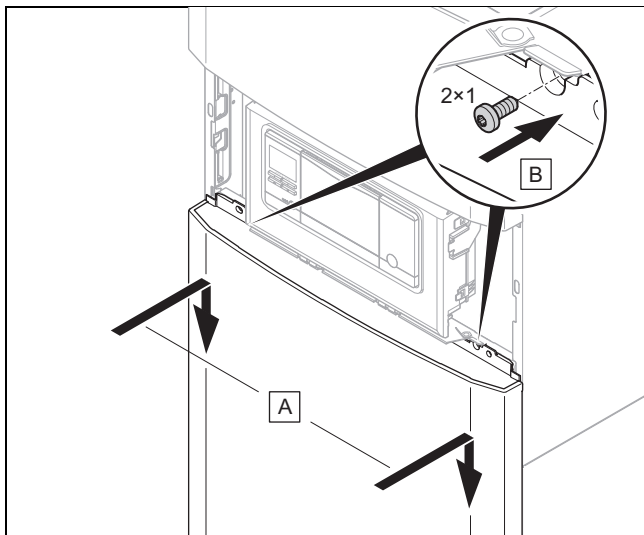

2. Hook the lower part of the front casing, using the retaining brackets, into the cut-outs in the side casings and lower it down.
3. Use the two screws to secure the lower part of the front casing.

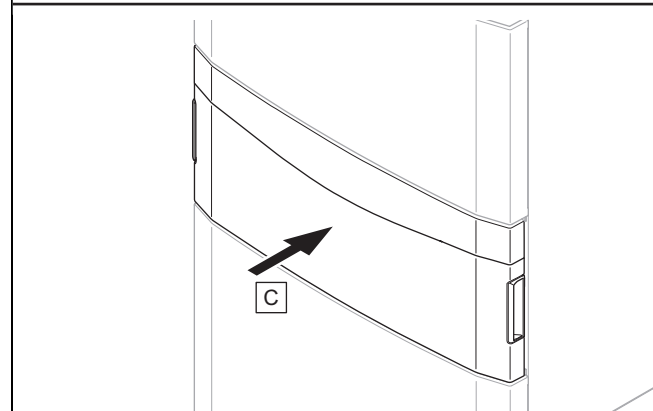
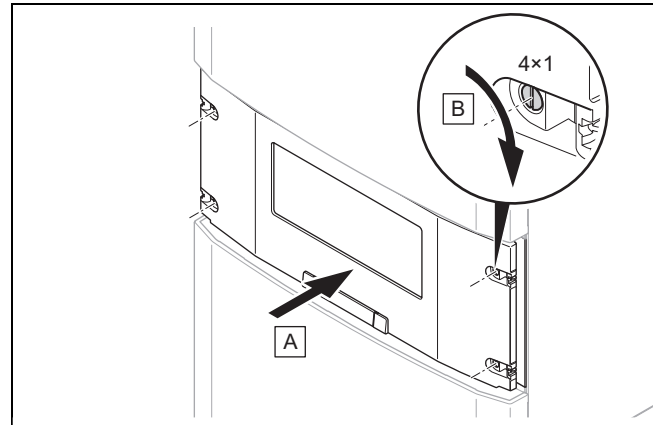

4. Insert the control panel cover and use the four screws to secure it in place.
5. Attach the control panel's front flap and check that the front flap can move easily when it is opened from either side.

4.10.2 Installing the side casing

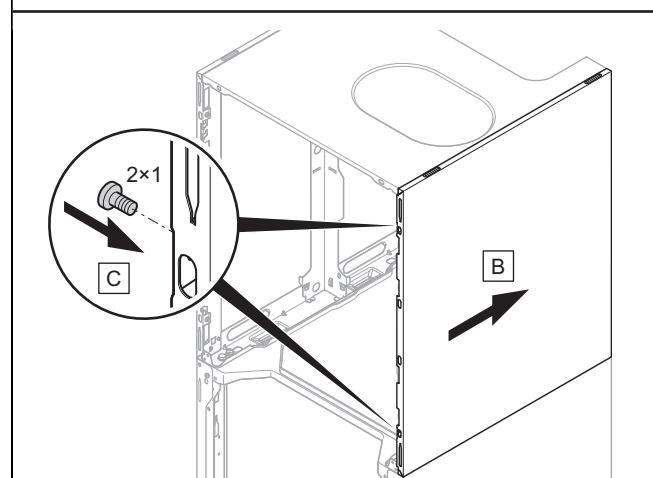
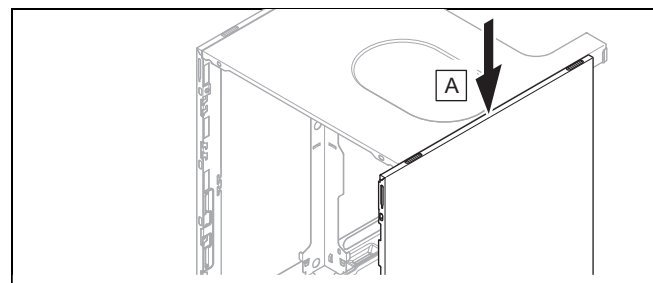

- Install the side casing as shown in the figure.

4.11 Moving the electronics box (optional)

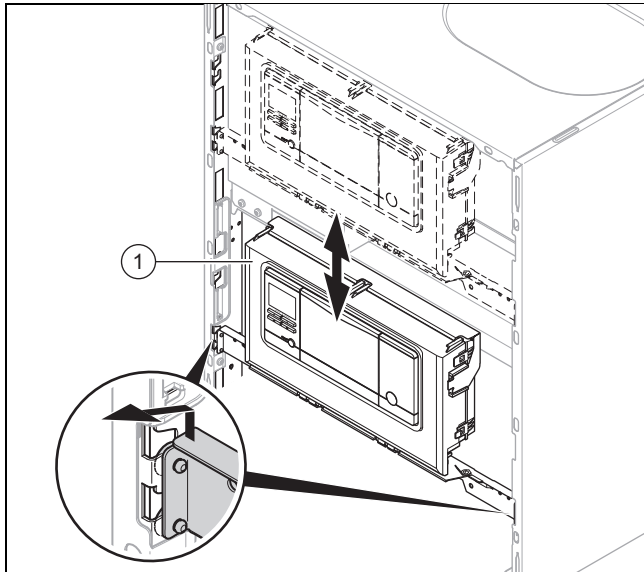

1. Push the electronics box (1) upwards and pull it towards you.
2. Move the electronics box into the required position.

4.12 Setting up the indoor unit

1. When setting up the product, take its weight, including the water content, into account.

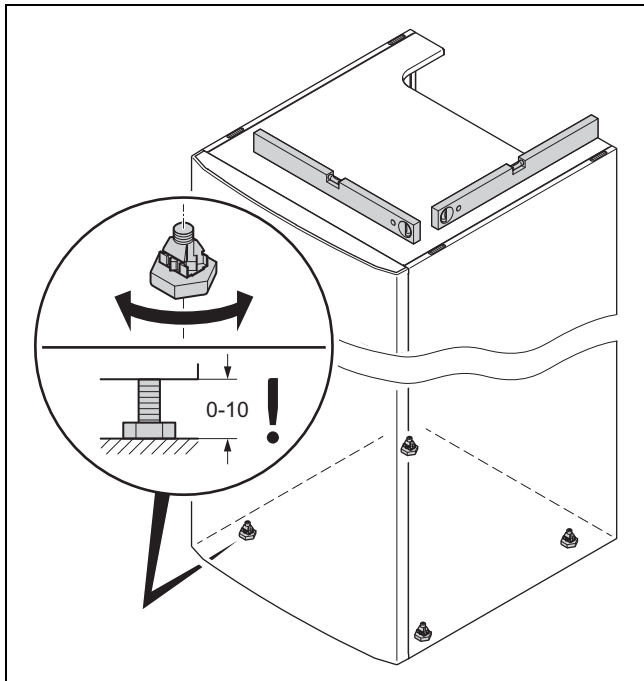

2. Orientate the product horizontally by adjusting the adjustable feet.

4.13 Removing the carrying straps

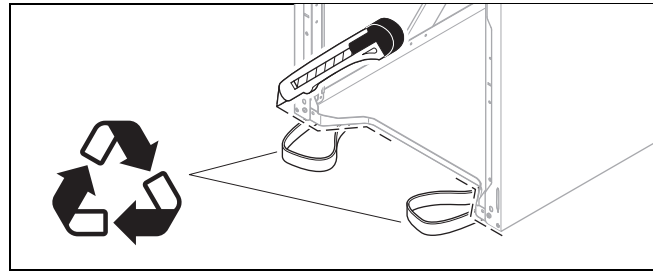

1. After you have set up the product, cut off the carrying straps and dispose of them in accordance with the relevant regulations.
2. Refit the front casing to the product.

5 Hydraulics installation

5.1 Carrying out the installation preparations

- ▶ Install the following components, preferably from the manufacturer's accessories:
 - An expansion relief valve, a stopcock and a manometer on the heating return
 - A domestic hot water safety assembly and a stopcock on the cold water supply
 - A stopcock on the heating flow
- ▶ Check whether the volume of the installed expansion vessel is sufficient for the heating system. If required, install an additional expansion vessel, connected as close to the product as possible, in the heating return.
- ▶ Install the connection pipes such that they are free from mechanical stress.
- ▶ If you are using metallic pipes to connect the pipe to the outdoor unit, earth the pipes.
- ▶ Heat-insulate the pipes.
- ▶ Only solder connectors if the connectors are not yet screwed to the service valves.
- ▶ Carefully flush the heating installation before connecting the product.
- ▶ Check whether the expansion relief valve's drain pipe-work opposite the outdoor air remains open, is installed in a frost-free environment, always runs downwards and visibly ends in an open drain.
- ▶ For heating installations with solenoid valves or thermostatically controlled valves, install a bypass with bypass valve in order to guarantee a volume flow of at least 40%.

5 Hydraulics installation

5.2 Connecting the heat pump to the indoor unit

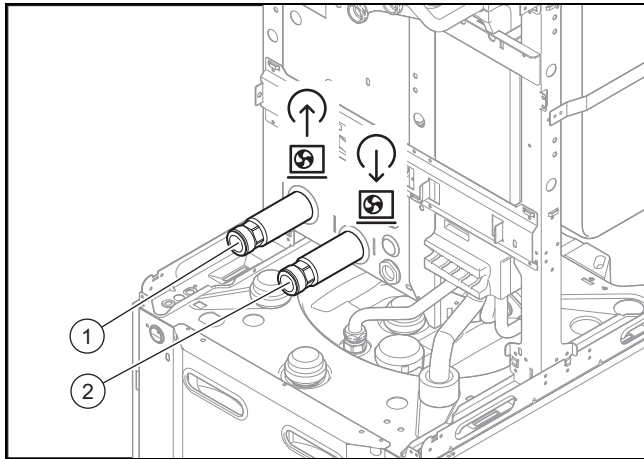

- 1 G 1 1/4" connection, heating flow from the heat pump
- 2 G 1 1/4" connection, heating return to the heat pump

1. Blow or flush the supply pipes thoroughly prior to installation.
2. Connect the heat pump to the product.
3. Check whether the connections are leak-tight. (→ Page 33)

5.3 Connecting the building circuit

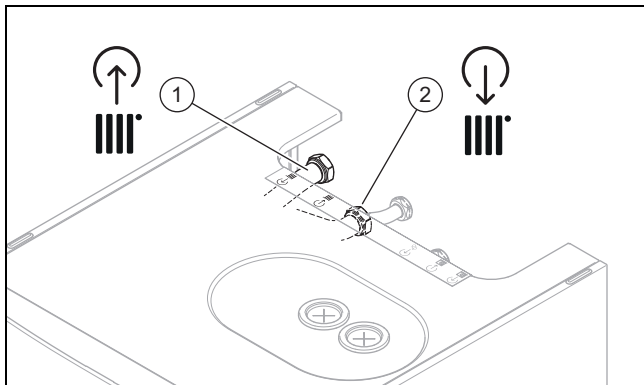

- ▶ Install the building circuit's flow (2) and return (1) in accordance with the relevant standards.

5.4 Installing the domestic hot and cold water connection

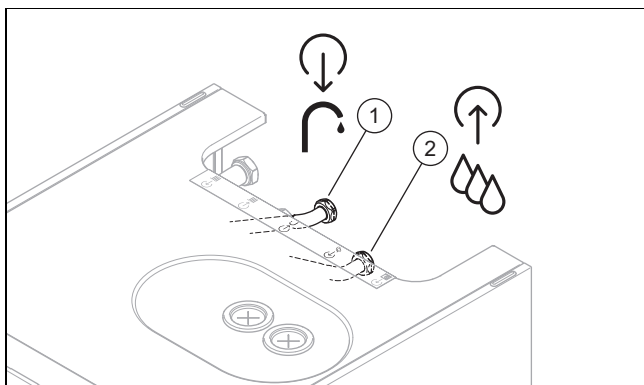

- ▶ Install the cold water connection (2) and the domestic hot water connection (1) in accordance with the relevant standards.

5.5 Installing potable water pipes

To connect the potable water pipes to the domestic hot water cylinder, various piping sets are offered as accessories for surface or concealed installation.

The piping, which is to be set up on-site, requires the following components:

- Domestic hot water thermostatic mixing valve
- Potable water expansion vessel, if required
- Pressure reducer in the cold water pipe (if required)
- Non-return valve in the heating circuit (if required)
- Service valves
- Circulation pump for anti-legionella function, if required

The domestic hot water thermostatic mixing valve ensures that the hot water from the cylinder is mixed with cold water to produce water with a maximum temperature between 30 and 70 °C as required. When starting up the heating installation, if you set the domestic hot water thermostatic mixing valve to the required maximum temperature, this maximum temperature is retained at the domestic hot water draw-off points.

- ▶ When installing the supply pipes, observe the set-up instructions that are included with the relevant accessories.
- ▶ To guarantee effective scald protection, set the thermostatic mixing valve to < 60 °C and check the temperature at a domestic hot water draw-off point.

5.6 Installing the drain pipe on the expansion relief valve

1. Install the drain pipe with a continuous downwards incline in a frost-free environment.
2. Ensure that the size of the drain pipe corresponds to the size of the expansion relief valve that has been checked with the type sample.
3. Ensure that the drain pipe has a maximum of two elbows and a maximum length of 2 m.
4. Make sure that the end of the pipe is visible.
5. Terminate the drain pipe in such a way that escaping water or steam cannot cause injury to persons or damage to electronic components.
6. Open the expansion relief valve regularly in order to remove any scale deposition and ensure that the device is not blocked.

5.7 Connecting the condensate discharge

Condition: Cooling mode activated

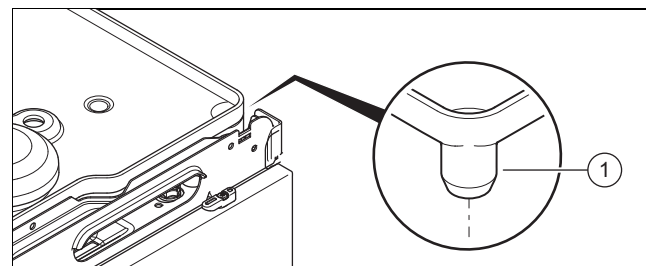

- ▶ Heat-insulate all of the pipes for the building circuit in the building.
- ▶ If the product is set up in the wet room and there is a large amount of condensate, you must connect a condensate discharge.
- ▶ Drill a hole into the hopper (1) on the condensate tray.

- Diameter: 8 mm
- ▶ Install a condensate discharge hose on the condensate tray on-site and connect it to the sewage system via a free drain.

5.8 Connecting additional components

You can install the following components:

- Domestic hot water circulation pump
- Domestic hot water expansion vessel
- External heating pump (multi-zone operation)
- External heating solenoid valve (multi-zone operation)
- Buffer cylinder for the heating system
- 2 l brine expansion vessel

Multiple-zone module and buffer cylinder cannot be installed at the same time, because they are installed at the same connections.

6 Electrical installation

6.1 Preparing the electrical installation



Danger!

Risk of death from electric shock as a result of an improper electrical connection!

An improper electrical connection may negatively affect the operational safety of the product and result in material damage or personal injury.

- ▶ Only carry out the electrical installation if you are a trained competent person and are qualified for this work.

1. Observe the technical connection conditions for connecting to the energy supply company's low-voltage network.
2. If the local power supply network operator requires that the heat pump is controlled using an ESCO blocking signal, install a corresponding contact switch as prescribed by the power supply network operator.
3. Determine whether the power supply for the product should be set up with a single-tariff meter or a dual-tariff meter.
4. Connect the product via a fixed connection and a partition with a contact gap of at least 3 mm.
5. Leave the cable cross-section for the connection cable to the distribution box unchanged.
6. If the power supply cable for this product is damaged, it must be replaced by the manufacturer or their customer service or a similarly qualified person in order to prevent any hazards.
7. Ensure that the nominal voltage of the power grid corresponds to that of the product's main power supply cabling.
8. Make sure that access to the power supply is always available and is not covered or blocked.

6.2 Requirements for the quality of the mains voltage

For the mains voltage of the single-phase 230 V network, a tolerance of +10% to -15% must be provided.

For the mains voltage of the three-phase 400 V network, a tolerance of +10% to -15% must be provided. For the voltage difference between the individual phases, a tolerance of +/- 2% must be provided.

6.3 Electrical partition

The electrical partitions are referred to as "disconnectors" in these instructions. The fuse or the circuit breaker that is installed in the building's meter/fuse box is usually used as the disconnector.

6.4 Installing components for the energy supply company lockout function

Condition: Energy supply company lockout function provided

The heat generation from the heat pump can be switched off temporarily by the energy supply company – usually by using a ripple control receiver. The unit can be shut down in two ways:

- The signal for the shutdown is fed to connection S21 for the indoor unit.
- The signal for the shutdown is fed to a partition that is installed on-site in the meter/fuse box.
- ▶ Install and wire additional components in the building's meter/fuse box. To do this, follow the wiring diagram in the appendix.

Option 1: Actuating connection S21

- ▶ Connect a 2-pole control cable to the relay contact (potential-free) for the ripple control receiver and to connection S21.



Note

In the event of control via connection S21, the energy supply does not have to be disconnected on-site.

- ▶ In the system control, set whether the electric back-up heater, the compressor or both should be blocked via S21.

Option 2: Disconnect the power supply with contactor

- ▶ Upstream of the indoor unit, install a contactor into the power supply for the low tariff.
- ▶ Install a 2-pole control cable. Connect the control output for the ripple control receiver to the control input for the contactor.
- ▶ Connect the power supply that is switched by the contactor to X300.



Note

When the energy supply (for the compressor or electric back-up heater) is switched off via the tariff contactor, S21 is not connected.

6 Electrical installation

6.5 Removing the cover from the power supply PCB

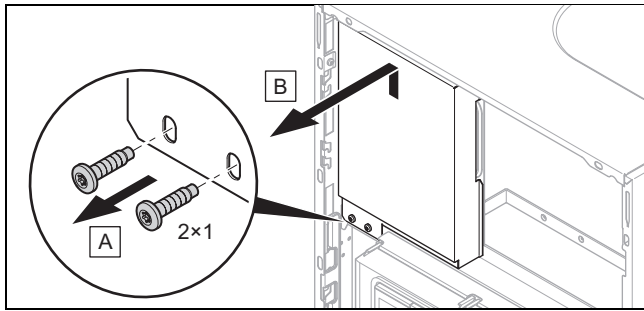

1. Remove the front casing. (→ Page 21)
2. Remove both screws.
3. Pull the cover for the power supply PCB forwards and out.

6.6 Routing the cables in the product

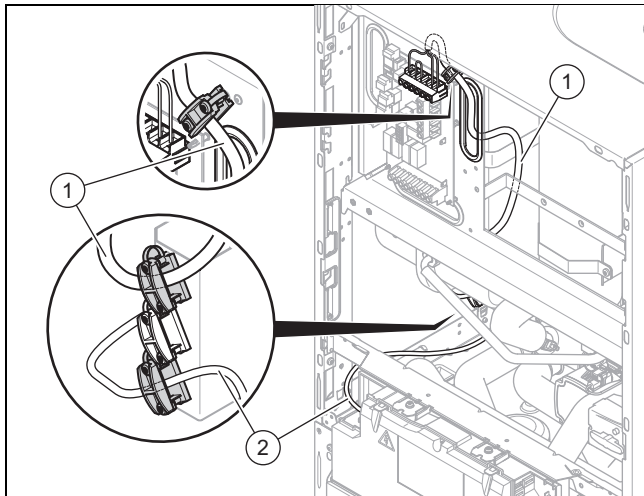

1. If required, remove the left-hand side casing.
2. Guide the power supply cable (1) and other connection cables (24 V/eBUS) (2) along the left-hand side casing in the product.
3. Guide the power supply cables through the strain reliefs and to the terminals on the power supply PCB.
4. Connect the power supply cable to the corresponding terminals.
5. Secure the power supply cable in the strain reliefs.

6.7 Establishing the power supply, 1~/230V

- Determine the type of connection:

Case	Connection type
Energy supply company lockout not provided	Single power supply
Energy supply company lockout provided, shutdown via connection S21	
Energy supply company lockout provided, shutdown via partition	Dual power supply

6.7.1 1~/230V single power supply

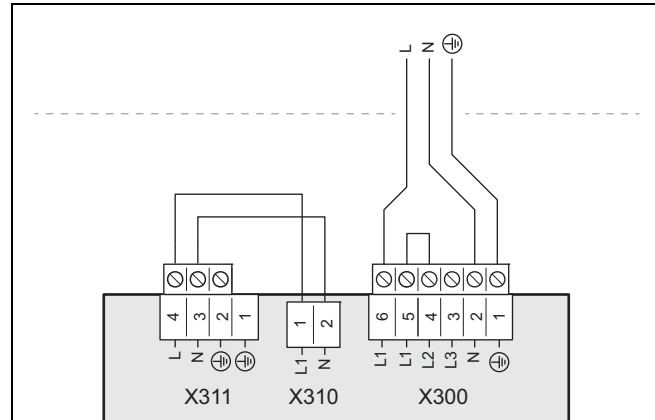

1. Note the specifications on the sticker on the electronics box.
2. Install a disconnector for the product.
3. Use the enclosed 3-pole power supply cable.
4. Connect the power supply cable to L1, N, PE.
5. Use the strain relief clamp to secure the cable in place.

6.7.2 1~/230V dual power supply

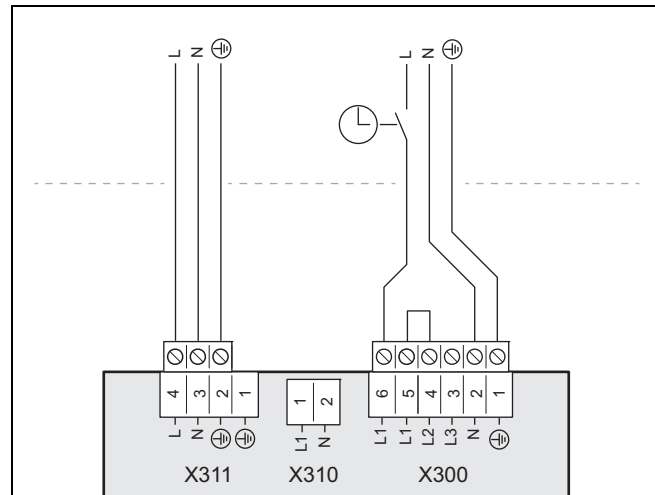

1. Note the specifications on the sticker on the electronics box.
2. Install two disconnectors for the product.
3. Use the enclosed 3-pole power supply cable and an additional 3-pole power supply cable with a temperature resistance of 90 °C.
 - Note that commercially available power supply cables do not usually have sufficient temperature resistance.
4. Connect the enclosed power supply cable (from the heat pump electricity meter) to connection X300.
5. Remove the 2-pole bridge between connections X310 and X311.
6. Connect the additional power supply cable (from the household electricity meter) to connection X311.
7. Use the strain relief clamps to secure the cables in place.

6.8 Establishing the power supply, 3~/400V

- Determine the type of connection:

Case	Connection type
Energy supply company lockout not provided	Single power supply
Energy supply company lockout provided, shutdown via connection S21	
Energy supply company lockout provided, shutdown via partition	Dual power supply

6.8.1 3~/400V single power supply

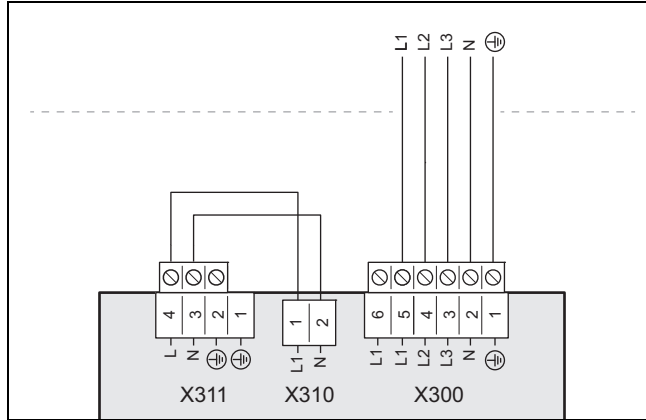

1. Note the specifications on the sticker on the electronics box.
2. Install a disconnector for the product.
3. Use the enclosed 5-pole power supply cable.
4. Remove the 2-pole bridge from between contacts L1 and L2 on connection X311.
5. Connect the power supply cable to connection X300.

6.8.2 3~/400V dual power supply

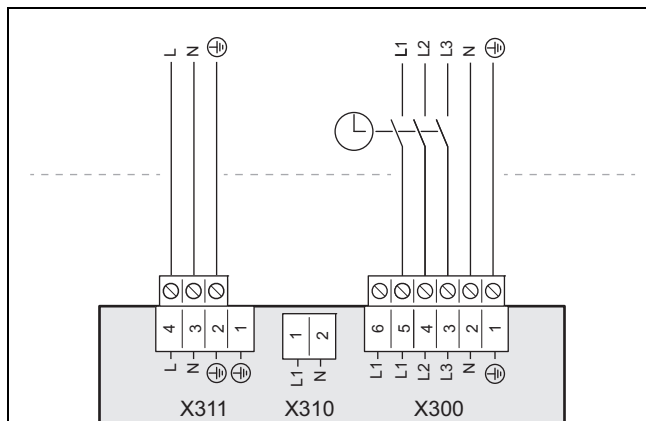

1. Note the specifications on the sticker on the electronics box.
2. Install two disconnectors for the product.
3. Use the enclosed 5-pole power supply cable (low tariff) and the enclosed 3-pole power supply cable (high tariff).
4. Remove the 2-pole bridge from between contacts L1 and L2 on connection X300.
5. Remove the 2-pole bridge between connections X310 and X311.

6. Connect the 5-pole power supply cable (from the heat pump electricity meter) to connection X300.
7. Connect the 3-pole power supply cable (from the household electricity meter) to connection X311.
8. Use the strain relief clamps to secure the cables in place.

6.9 Installing the system control in the electronics box

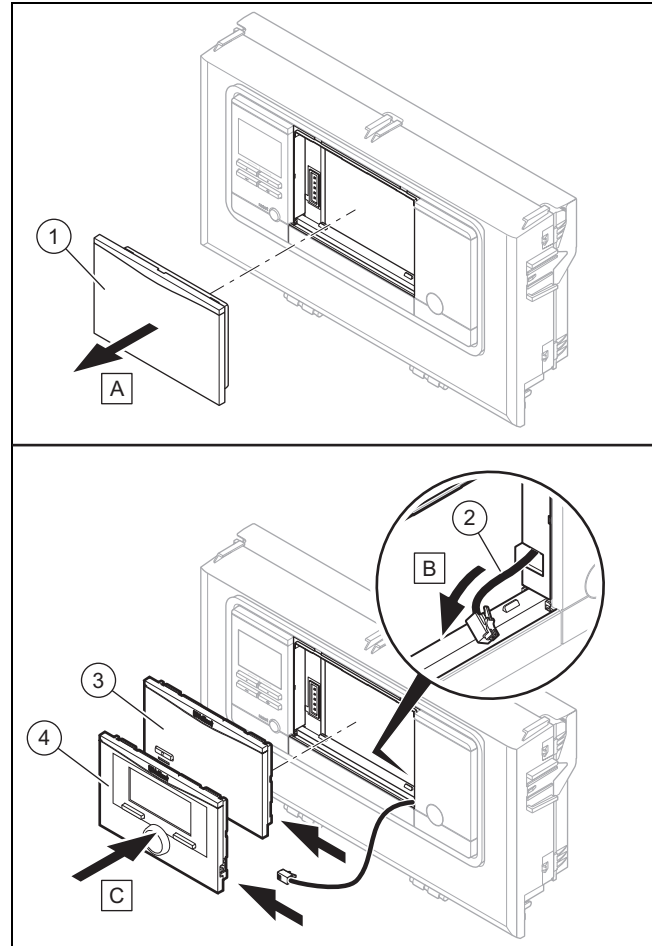

1. Remove the cover (1) on the electronics box.
2. Connect the DIF cable (2), which is laid out ready, either to the system control or to the mobile base station.
3. If you are using a radio receiver, use the mobile base station (3).
4. If you are using the wired system control, use the system control (4).
5. Consult the instructions for the system control for information on coupling the mobile base station and the system control.

6 Electrical installation

6.10 Opening the electronics box

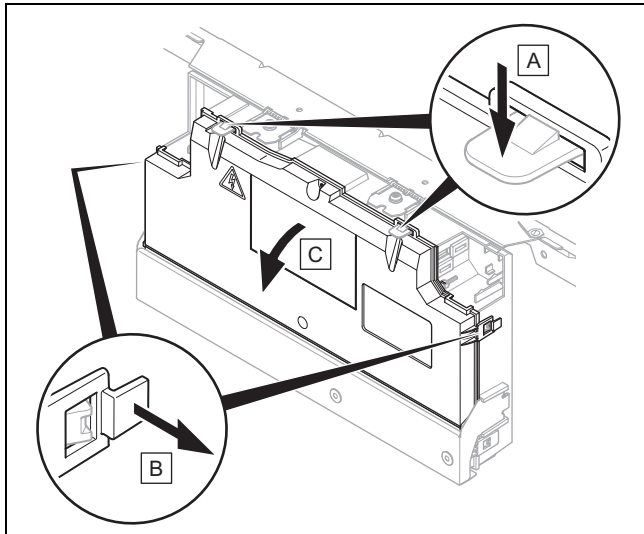

1. Hinge the electronics box forwards.
2. Detach the four clips, on the left and the right and at the top, from the brackets.

6.11 Routing the cables in the electronics box

1. At lengths of 10 m or more, mains voltage connection cables must be laid separately from sensor or bus lines. Minimum clearance for the extra low-voltage wire and power supply cable at a line length of > 10 m: 25 cm. If this is not possible, use shielded lines. Lay the shielding on one side of the sheet for the product's electronics box.

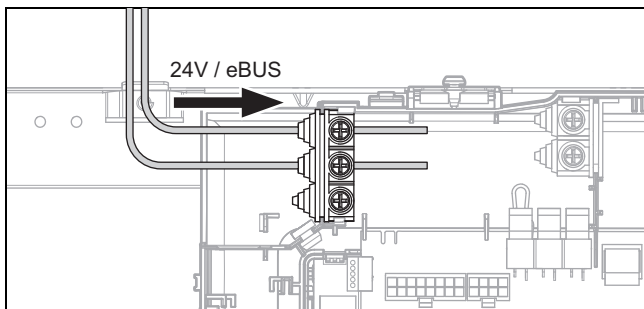

2. Route 24 V cables and eBUS cables through the left-hand strain reliefs on the electronics box.

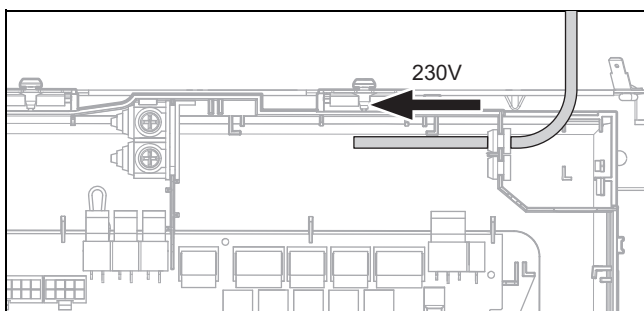

3. Route 230 V cables through the right-hand strain reliefs on the electronics box.

6.12 Carrying out the wiring

1. Ensure that the mains voltage is correctly disconnected from the safety extra-low voltage.
2. Only connect power supply cables to the terminals that are marked for the purpose.
3. Shorten the connection cables according to requirements.

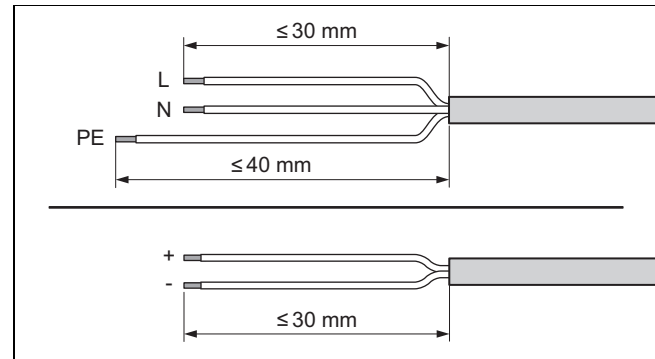

4. Strip the electrical wire as shown in the figure. In doing so, ensure that the insulation on the individual conductors is not damaged.
5. Ensure the inner conductor insulation is not damaged when stripping the outer sheathing.
6. Only strip inner conductors just enough to establish good, sound connections.
7. Fit conductor end sleeves on the stripped ends of the conductors.
8. Screw the respective plug to the connection cable.
9. Check whether all conductors are inserted mechanically securely in the terminals of the plug. Remedy this if necessary.
10. Plug the plug into the associated PCB slot.

6.13 Connecting the circulation pump

1. Route the 230 V connection cable for the circulation pump from the right and into the control PCB's electronics box.
2. Connect the 230 V connection cable to the plug from slot X11 on the control PCB and plug it into the slot.
3. Connect the connection cable for the external button using terminals 1 (0) and 6 (FB) on the X41 edge connector, which is supplied with the control.
4. Plug the edge connector into slot X41 on the control PCB.
5. Set the circulation pump in the system control.

6.14 Connecting a limit thermostat for the underfloor heating

Condition: Intermediate heat exchanger installed

- ▶ Remove the S20 plug for the bypass line at terminal X100 on the indoor unit's control PCB.
- ▶ Connect the limit thermostat to plug S20 for the indoor unit.

Condition: No intermediate heat exchanger installed

- ▶ Connect the limit thermostat to plug S20 for the outdoor unit, → aroTHERM plus operating and installation instructions.

6.15 Connecting the outdoor temperature sensor

Condition: No system control connected

- ▶ Connect an outdoor temperature sensor to plug *AF* on terminal *X41* on the control PCB.

6.16 Connecting the external prioritising diverter valve (optional)

- ▶ Connect the external prioritising diverter valve to *X14* on the control PCB.
 - The connection to a permanently live phase "L" with 230 V and to a switched phase "S" is available. Phase "S" is actuated by an internal relay and releases 230 V.

6.17 Connecting the VR 70/VR 71 mixer module

1. Connect the power supply for the **VR 70/VR 71** mixer module to *X314* on the power supply PCB.
2. Connect the **VR 70/VR 71** mixer module to the eBUS interface on the control PCB.

6.18 Installing the cover for the power supply PCB

1. Tighten all of the screws on the strain relief clamps.
2. Position the cover. Ensure that you do not damage any cables.
3. Use the two screws to secure the cover for the power supply PCB.

6.19 Checking the electrical installation

- ▶ After the installation is complete, check the electrical installation to ensure that the connections that have been established are secured properly and are sufficiently insulated.

7 Operation

7.1 Operating concept of the product

The operating concept and the display and setting options of the end user level are described in the operating instructions.

8 Start-up

8.1 Prioritising diverter valve, setting the heating circuit/cylinder charging

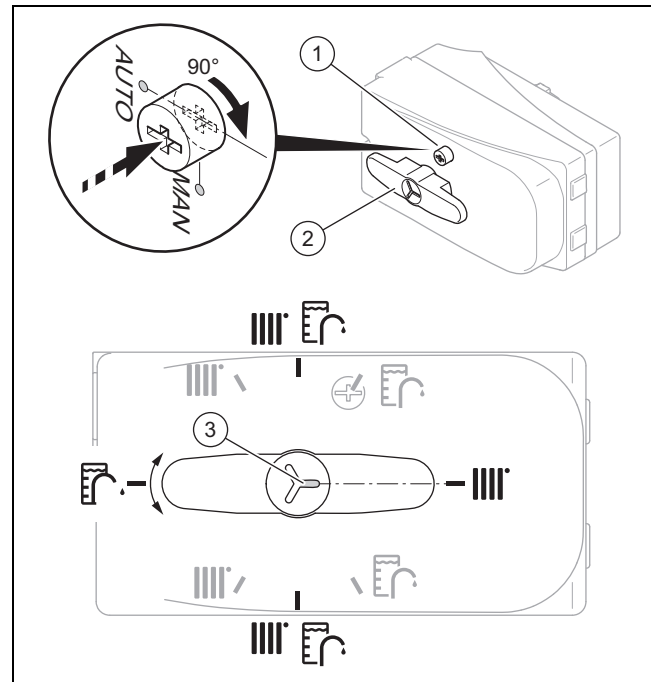

1. If you want to manually set the prioritising diverter valve, press the knob (1) and turn it 90° clockwise.
 - ◀ You can now turn the selection lever (2) to the required position.



Note

The notch (3) that points to the selection lever's extension displays the position of the selection lever. You can turn the selection lever by 90° each time to select heating, cylinder charging and the mid-position between heating/cylinder charging (black). In automatic mode, the selection lever can move to other intermediate positions (grey).

2. If you want to actuate the heating circuit, turn the selection lever (2) to "Heating circuit".
3. If you want to actuate the domestic hot water cylinder, turn the selection lever to "Domestic hot water cylinder".
4. If you want to actuate the heating circuit and the domestic hot water cylinder, turn the selection lever to "Heating circuit/domestic hot water cylinder".

8.2 Checking and treating the heating water/filling and supplementary water



Caution.

Risk of material damage due to poor-quality heating water

- ▶ Ensure that the heating water is of sufficient quality.

- ▶ Before filling or topping up the installation, check the quality of the heating water.

8 Start-up

Checking the quality of the heating water

- ▶ Remove a little water from the heating circuit.
- ▶ Check the appearance of the heating water.
- ▶ If you ascertain that it contains sedimentary materials, you must desludge the installation.
- ▶ Use a magnetic rod to check whether it contains magnetite (iron oxide).
- ▶ If you ascertain that it contains magnetite, clean the installation and apply suitable corrosion-inhibition measures, or fit a magnetic filter.
- ▶ Check the pH value of the removed water at 25 °C.
- ▶ If the value is below 8.2 or above 10.0, clean the installation and treat the heating water.
- ▶ Ensure that oxygen cannot get into the heating water.

Checking the filling and supplementary water

- ▶ Before filling the installation, measure the hardness of the filling and supplementary water.

Treating the filling and supplementary water

- ▶ Observe all applicable national regulations and technical rules when treating the filling and supplementary water.

Provided the national regulations and technical rules do not stipulate more stringent requirements, the following applies:

You must treat the heating water in the following cases

- If the entire filling and supplementary water quantity during the operating life of the system exceeds three times the nominal volume of the heating installation, or
- If the guideline values listed in the following table are not met, or
- If the pH value of the heating water is less than 8.2 or more than 10.0.

Total heating output	Water hardness at specific system volume ¹⁾					
	≤ 20 l/kW		> 20 l/kW ≤ 50 l/kW		> 50 l/kW	
kW	°dH	mol/m ³	°dH	mol/m ³	°dH	mol/m ³
< 50	< 16.8	< 3	11.2	2	0.11	0.02
> 50 to ≤ 200	11.2	2	8.4	1.5	0.11	0.02
> 200 to ≤ 600	8.4	1.5	0.11	0.02	0.11	0.02
> 600	0.11	0.02	0.11	0.02	0.11	0.02

1) Nominal capacity in litres/heating output; in the case of multi-boiler systems, the smallest single heating output is to be used.



Caution.

Risk of material damage if the heating water is treated with unsuitable additives.

Unsuitable additives may cause changes in the components, noises in heating mode and possibly subsequent damage.

- ▶ Do not use any unsuitable antifreeze and corrosion inhibitors, biocides or sealants.

No incompatibility with our products has been detected to date with proper use of the following additives.

- ▶ When using additives, follow the manufacturer's instructions without exception.

We accept no liability for the compatibility of any additive or its effectiveness in the rest of the heating system.

Additives for cleaning measures (subsequent flushing required)

- Adey MC3+
- Adey MC5
- Fernox F3
- Sentinel X 300
- Sentinel X 400

Additives intended to remain permanently in the installation

- Adey MC1+
- Fernox F1
- Fernox F2
- Sentinel X 100
- Sentinel X 200

Additives for frost protection intended to remain permanently in the installation

- Adey MC ZERO
- Fernox Antifreeze Alphi 11
- Sentinel X 500

- ▶ If you have used the above-mentioned additives, inform the end user about the measures that are required.
- ▶ Inform the end user about the measures required for frost protection.

8.3 Filling and purging the heating installation

1. Flush the heating installation thoroughly prior to filling.
2. Open all of the thermostatic valves on the heating installation and, if required, all other isolation valves.
3. Check all of the connections and the entire heating installation for leaks.
4. Switch the prioritising diverter valve to manual operation (→ Page 29) and turn the selection lever to "Heating circuit/domestic hot water cylinder".
 - ◁ Both valves are open and the filling procedure is improved since the air in the system can escape.
 - ◁ The heating circuit and the spiral immersion heater for the domestic hot water cylinder are filled at the same time.

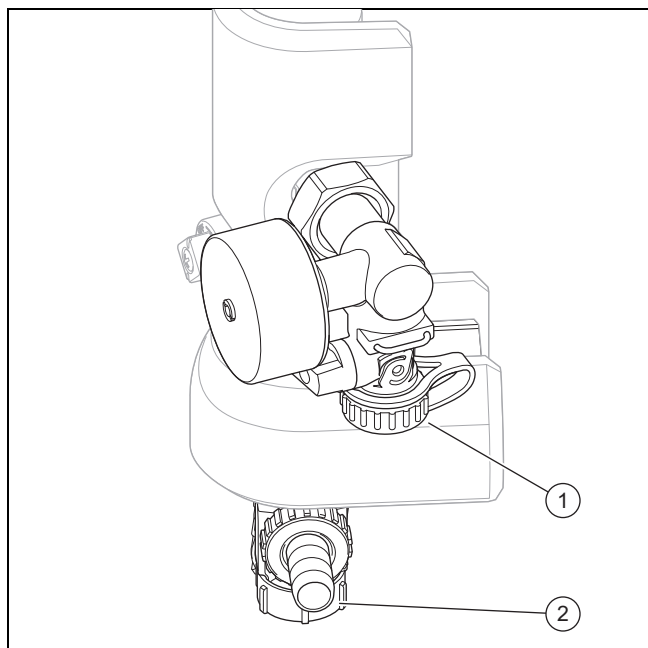

5. Connect a filling hose to the filling/draining valve (1).

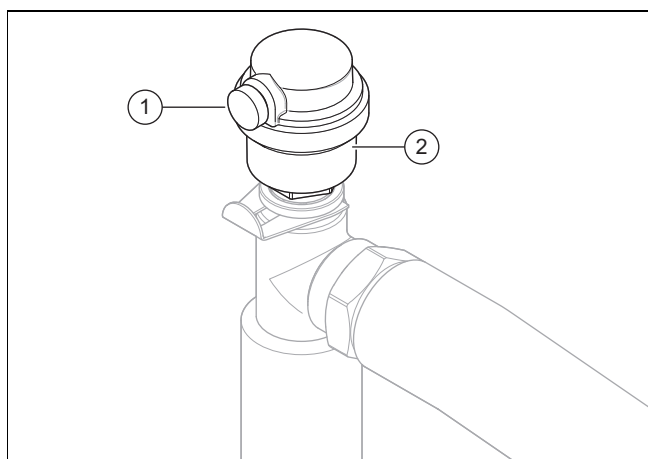

6. Open the purging screw (1) on the automatic air vent (2) in order to purge the product.
7. Open the filling/draining valve.
8. Open the heating water supply slowly.
9. Purge the highest radiator or underfloor heating circuit and wait until the circuit is completely purged.
10. Fill with water until the manometer (on-site) shows that the heating installation has reached a pressure of approx. 1.5 bar.
11. Close the filling/draining valve.
12. Then check the heating installation pressure again (if required, repeat the filling procedure).
13. Remove the filling hose from the filling/draining valve and screw the screw cap back on.
14. Set automatic mode for the prioritising diverter valve again (→ Page 29).

8.4 Filling the domestic hot water circuit

1. Open all domestic hot water tap fittings.
2. Wait until water escapes from each draw-off point and then close all the hot water taps.
3. Check the system for tightness.

8.5 Purging

1. Open the automatic air vent.
2. Start the purge programme for the building circuit P06 via: **Menu** → **Installer level** → **Test menu** → **Check programmes** → **Purge building circuit**.
3. Allow the P06 function to run for 60 minutes.
4. Once both purge programmes have finished, check whether the pressure in the heating circuit is 150 kPa (1.5 bar).
 - ◁ Top up with water if the pressure is below 150 kPa (1.5 bar).

8.6 Switching on the product



Note

The product does not have an on/off switch. The product is switched on as soon as it is connected to the power grid.

1. Use the partition that is installed on-site to switch the product on.
 - ◁ The display shows the basic display.
 - ◁ The basic display appears on the system control display.
 - ◁ The system's products start up.
 - ◁ The heating and domestic hot water demand are activated by default.
2. When you start up the heat pump system for the first time after electrical installation, the installation assistants for the system components will start automatically. Set the required values on the control panel of the indoor unit first, then on the optional system control and the other system components.

8.7 Running the installation assistants

The installation assistant is launched when the product is switched on for the first time. It provides direct access to the most important check programmes and configuration settings for starting up the product.

Confirm the launch of the installation assistant. All heating and domestic hot water demands are blocked whilst the installation assistant is active.

Set the following parameters:

- Language
- System control present
- Immersion heater power supply (electric back-up heater)
- Immersion heater power limit (electric back-up heater)
- Cooling technology
- Compressor current limit
- Relay multi-function output
- Intermediate heat exchanger present
- Check programme: Purge building circuit
- Contact details, Telephone number

8 Start-up

To access the next item, confirm by pressing **Next** in each case.

If you do not confirm the launch of the installation assistant, it is closed 10 seconds after you switch on the unit and the basic display then appears. If the installation assistant does not run through completely, it restarts the next time the unit is switched on.

8.7.1 Ending the installation assistant

- ▶ Once you have run through the installation assistant successfully, confirm by pressing .
- ◀ The installation assistant will close and will not launch again when the product is next switched on.

8.8 Menu functions without the optional system control

If no system control is installed and this has been confirmed in the installation assistant, the following additional functions are displayed in the product's control panel:

- End user level
 - **Room temperature setpoint**
 - **Screed drying activ.**
 - **Target cylinder temp.**
 - **Domestic hot water cylinder temp.**
 - **Manual cooling activation**
- Installer level
 - **Heat curve**
 - **Summer sw.-off temp.**
 - **Heating biv. point**
 - **DHW bivalence point**
 - **Heating alt. point**
 - **Max. flow temperature**
 - **Min. flow temperature**
 - **Heating mode activ.**
 - **DHW activation**
 - **Cyl. charg. hysteresis**
 - **Limp home mode Immersion heater: Heating/DHW**
 - **Cooling target flow**
 - **Screed drying day**

If the system control has been retroactively removed or a defect is present, you must reset the product to the factory setting and select the system control in the installation assistant in order to obtain the additional functions in the product's control panel.

8.9 Enabling the electric back-up heater

The electric back-up heater is controlled automatically and according to demand. Set the maximum output for the electric back-up heater at the indoor unit's control panel here.

On the system control, you can select whether the electric back-up heater is to be used for heating mode, domestic hot water mode or both modes.

- ▶ Activate the internal electric back-up heater with one of the output levels.
- ▶ You can find the output levels for the electric back-up heater in the tables in the appendix.
 - 5.4 kW back-up heater at 230 V (→ Page 54)
 - 8.54 kW back-up heater at 400 V (→ Page 55)
- ▶ Ensure that the maximum output for the electric back-up heater does not exceed the output of the fuse protection for the household electricity system .

8.10 Setting the anti-legionella function

- ▶ Set the anti-legionella function using the system control.

To ensure sufficient anti-legionella protection, the electric back-up heater must be activated.





Condition: Internal electric back-up heater deactivated or external back-up heater

The anti-legionella function can be used without a back-up heater in the outdoor temperature range of -10 °C to +30 °C; outside of this temperature range, the function can only be used with an activated internal or external back-up heater.

An external back-up heater must be protected against overheating, for example, so that it is intrinsically safe. An external back-up heater must be connected to contact X14 via a cut-off relay. On the indoor unit's control, the setting must be converted to the external back-up heater under **MA relay**.

Menu → Installer level → Configuration.

8.11 Calling up the installer level

1. Press  and  at the same time.
2. Navigate to **Menu → Installer level** and confirm by pressing  (**OK**).
3. Set the value **17** and confirm by pressing .

8.12 Checking the configuration

You can recheck and set the most important system parameters. Call up **Configuration** to configure the menu item.

Menu → Installer level → Configuration.

8.13 Calling up statistics

Menu → Installer level → Test menu → Statistics

You can use this function to call up the statistics for the heat pump.

8.14 Displaying the filling pressure in the building circuit

The product has a pressure sensor in the heating circuit and a digital pressure display.

- ▶ Select **Menu Live Monitor** to display the filling pressure in the building circuit.

8.15 Checking function and leak-tightness

Before you hand the product over to the end user:

- ▶ Check that the heating installation (heat generator and system) and the domestic hot water pipes are leak-tight.
- ▶ Check whether the drain pipework for the purging connections has been installed correctly.

8.15.1 Checking the heating mode

- ▶ Start check programme P.04.

8.15.2 Checking the domestic hot water generation

- ▶ Check whether the cylinder is purged and the domestic hot water temperature is reached.

8.16 Floor drying

- Condition: No system control connected



Caution.

Risk of damage to the product caused by impermissible purging

Without purging the heating circuit, the system may become damaged.

- ▶ If the screed drying is activated without a system control, purge the system manually. No automatic purging takes place.

- You can use this function to "dry heat" freshly laid screed in accordance with the construction regulations, according to a defined time and temperature schedule, without the need for a system control to be connected.

VIH QW 190/6

If there is no electric back-up heater, screed drying is only possible with this product if the return temperature is above 10 °C. This corresponds approximately to an outdoor temperature of +5 °C. At outdoor temperatures below +5 °C, there is a risk of increased icing of the fin-type heat exchanger in the outdoor unit.

When screed drying is activated, all the selected operating modes are interrupted. The function controls the flow temperature of the controlled heating circuit according to a pre-set programme, regardless of the outdoor temperature.

The display shows the target flow temperature. You can manually set the current day.

Days after starting the function	Target flow temperature for this day [°C]
1	25
2	30
3	35
4	40
5	45
6-12	45
13	40
14	35
15	30

Days after starting the function	Target flow temperature for this day [°C]
16	25
17-23	10 (frost protection function, pump in operation)
24	30
25	35
26	40
27	45
28	35
29	25

The day is always changed at 00:00, irrespective of when the function starts.

After a mains Off/On, screed drying starts with the last active day.

The function ends automatically when the last day of the temperature profile has elapsed (day = 29) or if you set the start day to 0 (day = 0).

8.17 Starting up the optional system control

The following work for starting up the system was carried out:

- The system control and the outdoor temperature sensor have been installed and wired.
- Start-up of all system components (except for the system control) is complete.

Follow the installation assistant and the operating and installation instructions for the system control.

9 Adapting the unit to the heating installation

9.1 Configuring the heating installation

To adjust the water flow rate that is created by the heat pump to the relevant installation, the maximum available remaining feed head can be set for the heat pump in heating and domestic hot water mode and the output of the building circuit pump for heating, cooling and domestic hot water.

Since the heat pump installation regulates the building circuit pump at the nominal flow in automatic mode, only set the parameters where required.

You can call up these parameters via **Menu → Installer level → Configuration**.

The adjustment range for the remaining feed head is between 20 kPa (200 mbar) and 90 kPa (900 mbar). The heat pump operates at its optimum level when the nominal flow can be achieved by setting the available pressure (Delta T = 5 K).

10 Troubleshooting

9.2 Total pressure loss in the product, building circuit

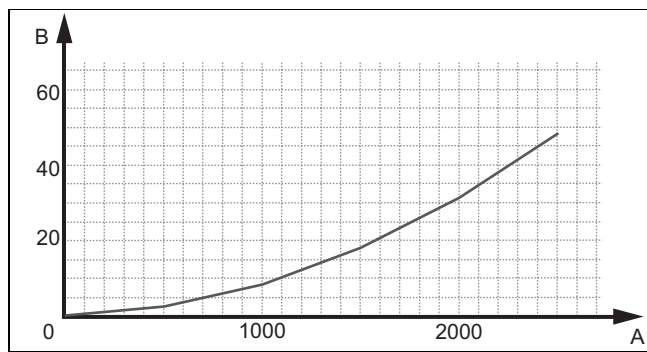

A Flow rate in the building circuit (l/h) B Pressure loss (kPa)

9.3 Total pressure loss in the product, domestic hot water

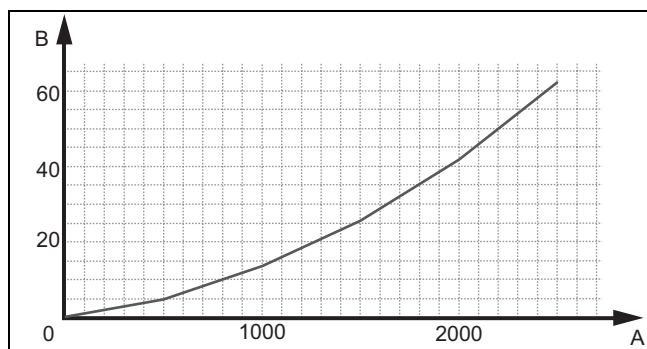

A Flow rate in the domestic hot water circuit (l/h) B Pressure loss (kPa)

9.4 Instructing the end user



Danger!

Risk of death from legionella.

Legionella multiply at temperatures below 60 °C.

- ▶ Ensure that the end user is familiar with all of the Anti-legionella measures in order to comply with the applicable regulations regarding legionella prevention.

- ▶ Explain to the end user how the safety devices work and where they are located.
- ▶ Inform the end user about all of the anti-legionella measures.
- ▶ Inform the end user how to handle the product.
- ▶ Draw particular attention to the safety warnings, which the end user must follow.
- ▶ Inform the end user that they must have the product maintained in accordance with the specified intervals.
- ▶ Explain to the end user how to check the system's water volume/filling pressure.
- ▶ Pass all of the instructions and documentation for the product to the end user for safe-keeping.

10 Troubleshooting

10.1 Contacting your service partner

If you contact your service partner, please mention if possible:

- The fault code that is displayed (**F.xx**)
- The status code (**S.xx**) that is displayed by the product in the Live Monitor

10.2 Reading off the fault codes

If a fault develops in the product, the display shows a fault code **F.xx**.

Fault codes have priority over all other displays.

If multiple faults occur at the same time, the display shows the corresponding fault codes for two seconds each in sequence.



- ▶ Eliminate the fault.
- ▶ To start up the product again, press the reset button (Operating instructions).
- ▶ If you are unable to eliminate the fault and the fault recurs despite several reset attempts, contact Customer Service.

10.3 Querying the fault memory

The product has a fault memory. You can use this to query the last ten faults that occurred in chronological order.

To call up the fault memory, select **Menu** → **Installer level** → **List of faults**.

The display shows:

- Number of faults that occurred
 - The fault that is currently selected with fault number **F.xx**
 - A plain text display explaining the fault.
- ▶ Use the  or  button to display the last ten faults that occurred.

10.4 Resetting the fault memory

- ▶ Press  twice and then **Delete** and **OK** to delete the fault list.

10.5 Displaying Live Monitor (status codes)

Status codes in the display provide information on the product's current operating mode. These can be called up via the **Live Monitor** menu.

10.6 Using the function menu

You can use the function menu to actuate and test individual components of the product during the fault diagnostics. (→ Page 35)

10.7 Carrying out the actuator test

Menu → **Installer level** → **Test menu** → **Sensor/actuator test**

You can check that the components of the heating installation are functioning correctly using the sensor/actuator test. You can actuate more than one actuator at a time.

If you do not select anything to change, you can have the current control values for the actuators and the sensor values displayed.

You can find a list of the sensor characteristic values in the appendix.

Characteristic values for the internal temperature sensors, hydraulic circuit (→ Page 55)

Characteristic values for the VRC DCF outdoor temperature sensor (→ Page 57)

10.8 Safety cut-out

The product has a safety cut-out.

If the safety cut-out has tripped, the cause must be eliminated and the safety cut-out replaced.

- ▶ See the "Fault codes" table in the appendix. Fault codes (→ Page 50)
- ▶ Check the back-up heater for damage due to overheating.
- ▶ Check that the power supply for the power supply PCB is working properly.
- ▶ Check the cabling for the power supply PCB.
- ▶ Check the cabling for the electric back-up heater.
- ▶ Check that all temperature sensors are working properly.
- ▶ Check that all other sensors are working properly.
- ▶ Check the pressure in the heating circuit.
- ▶ Check that the heating circuit pump is working properly.
- ▶ Check whether there is air in the heating circuit.

10.8.1 Replace the safety cut-out

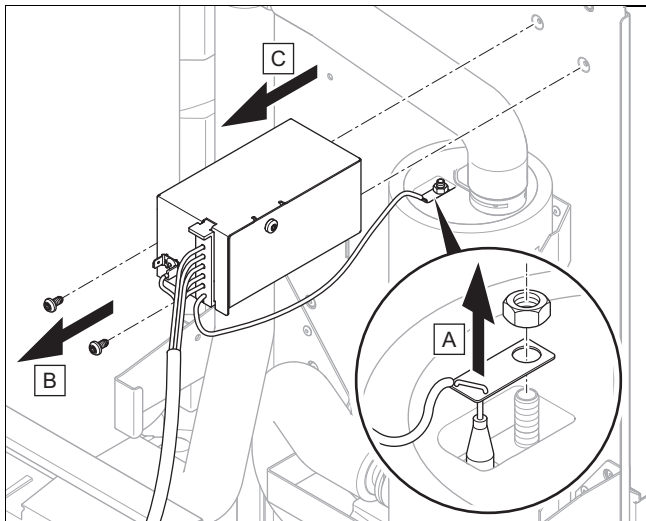

1. Disconnect the product from the power grid and protect it against being switched back on.
2. Remove the front casing.
3. Remove the cover from the power supply PCB. (→ Page 26)
4. Remove the connection cable from terminal block X302.

5. Remove the capillary tube from the temperature sensor on the electric back-up heater.
6. Remove both screws and remove the safety cut-out with the retainer from the product.
7. Install the new safety cut-out in reverse order.

10.9 Resetting parameters to factory settings

- ▶ Select **Menu** → **Menu** → **Installer level** → **Resets** to reset all of the parameters at the same time and to restore the product to the factory settings.

11 Inspection and maintenance

11.1 Procuring spare parts

The original components of the product were also certified by the manufacturer as part of the declaration of conformity. If you use other, non-certified or unauthorised parts during maintenance or repair work, this may void the conformity of the product and it will therefore no longer comply with the applicable standards.

We strongly recommend that you use original spare parts from the manufacturer as this guarantees fault-free and safe operation of the product. To receive information about the available original spare parts, contact the contact address provided on the back page of these instructions.

- ▶ If you require spare parts for maintenance or repair work, use only the spare parts that are permitted for the product.

11.2 Checking maintenance messages

If the  symbol is shown in the display, the product requires maintenance work or the product is in comfort protection mode.

- ▶ To obtain further information, call up the **Live Monitor**.
- ▶ Carry out the maintenance work that is listed in the table. Maintenance messages (→ Page 49)

Condition: Lhm.XX is displayed

The product is in Comfort protection mode. The product has detected a permanent fault and continues to run with restricted comfort.

- ▶ To determine which component is defective, read the fault memory (→ Page 34).



Note

If a fault message is present, the product remains in comfort protection mode after it is reset. After the product is reset, the fault message is displayed first before the message **Limp home mode (comfort protection)** appears again.

- ▶ Check the component that is displayed and replace it, if required.

12 Draining

11.3 Observing inspection and maintenance intervals

- ▶ Adhere to the minimum inspection and maintenance intervals. Carry out all of the work that is listed in the "Inspection and maintenance work" table in the appendix.
- ▶ Carry out maintenance work on the product at an earlier point if the results of the inspection that was carried out during previous maintenance make this necessary.

11.4 Preparing for inspection and maintenance

Observe the basic safety rules before carrying out inspection and maintenance work or installing spare parts.

- ▶ Switch off the product.
- ▶ Disconnect the product from the power supply.
- ▶ Secure the product against being switched back on again.
- ▶ When working on the product, protect all electric components from spraying water.
- ▶ Remove the front casing.

11.5 Using check programmes

You can call up the check programmes via **Menu** → **Installer level** → **Test menu** → **Check programme**.

If the product is in error condition, you cannot start any check programmes. You can detect an error condition by the fault symbol shown in the left bottom corner of the display. You must first reset.

To end the check programmes, you can press **Cancel** at any time.

11.6 Checking the pre-charge pressure of the expansion vessel

1. Close the service valves and drain the heating circuit. (→ Page 36)

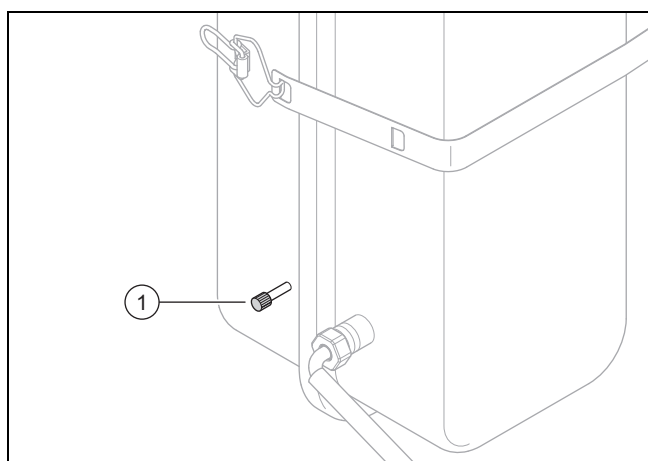

2. Measure the pre-charge pressure of the expansion vessel (1) at the valve (2).
3. If the pressure is below 0.075 MPa (0.75 bar) (depending on the static pressure of the heating installation), use nitrogen to fill the expansion vessel.
4. Fill the heating circuit.

11.7 Checking the magnesium protection anode

1. Drain the product's domestic hot water circuit. (→ Page 37)

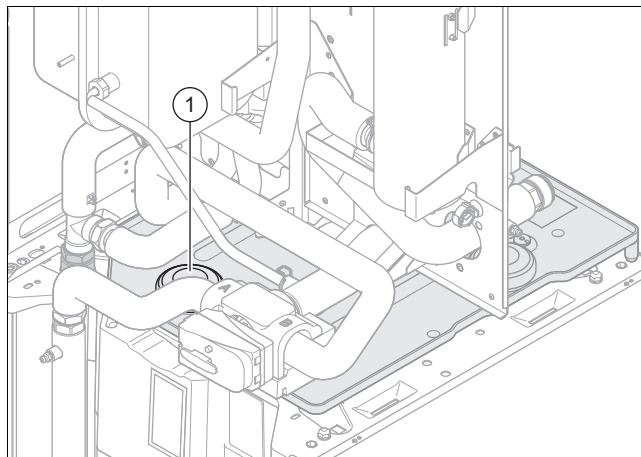

2. Remove the heat insulation from the magnesium protection anode (1).
3. Unscrew the magnesium protection anode from the cylinder and check the extent to which it has corroded.
4. If the anode is more than 60% worn, replace it.
5. Screw the anode back onto the cylinder after inspection.
6. Fill the cylinder and then check whether the threaded connection of the anode is leak-tight.
7. Purge the circuit.

11.8 Cleaning the domestic hot water cylinder

1. Drain the domestic hot water cylinder.
2. Remove the protection anode from the cylinder.
3. Use a jet of water through the anode opening on the cylinder to clean the cylinder interior.
4. Rinse sufficiently and allow the water used for cleaning to flow out via the cylinder drain cock.
5. Close the draining cock.
6. Refit the protection anode to the cylinder.
7. Fill the cylinder with water and check whether it is leak-tight.
8. Actuate the draining device on the domestic hot water safety assembly regularly in order to remove any scale deposition, and ensure that the device is not blocked.

12 Draining

12.1 Draining the product's heating circuit

1. Close the service valves in the heating flow and in the heating return.
2. Remove the front casing. (→ Page 21)
3. Remove the side casing. (→ Page 21)

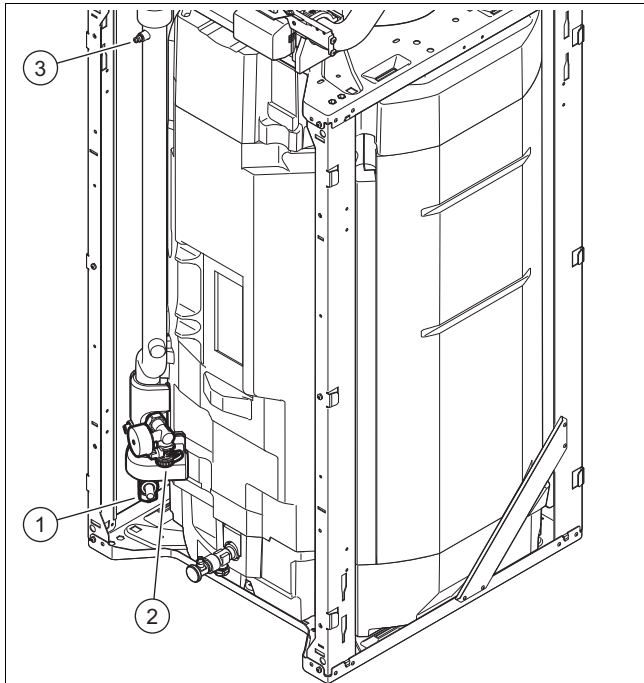

4. Connect a hose to each of the draining cocks (1) and (2), and guide the ends of the hoses to a suitable drainage point.
5. Use manual actuation to move the prioritising diverter valve to the "Heating circuit/domestic hot water cylinder" position. (→ Page 29)
6. Open the automatic air vent (red wheel).
7. After five minutes, open the air vent (3). If required, close it again if water is escaping.
8. Open the two stopcock in order to fully drain the heating circuit, including the heating coil for the domestic hot water cylinder.

12.2 Draining the product's domestic hot water circuit

1. Unlock the cold water connection.
2. Remove the front casing. (→ Page 21)

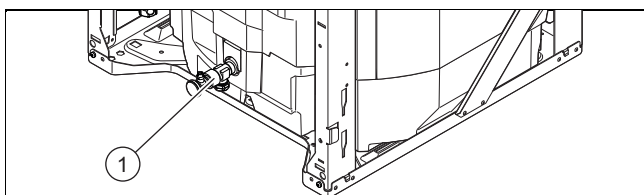

3. Connect a hose to the connection on the draining cock (1) and route the free end of the hose to a suitable drainage point.
4. Open the draining cock (1) to fully drain the product's domestic hot water circuit.
5. Open one of the 3/4 connections on the rear of the product on the domestic hot water cylinder.

13 Decommissioning

13.1 Decommissioning the product

- ▶ Disconnect the product from the power grid.
- ▶ Close the cold-water stopcock.
- ▶ Close the heating stopcock (flow and return).
- ▶ Drain the product.

14 Recycling and disposal

Disposing of the packaging

- ▶ Dispose of the packaging correctly.
- ▶ Observe all relevant regulations.

Disposing of the product and accessories

- ▶ Do not dispose of the product or the accessories with household waste.
- ▶ Dispose of the product and all accessories correctly.
- ▶ Observe all relevant regulations.

15 Customer service

For contact details for our customer service department, you can write to the address that is provided on the back page, or you can visit www.vaillant.com.

Appendix

Appendix

A Functional diagram

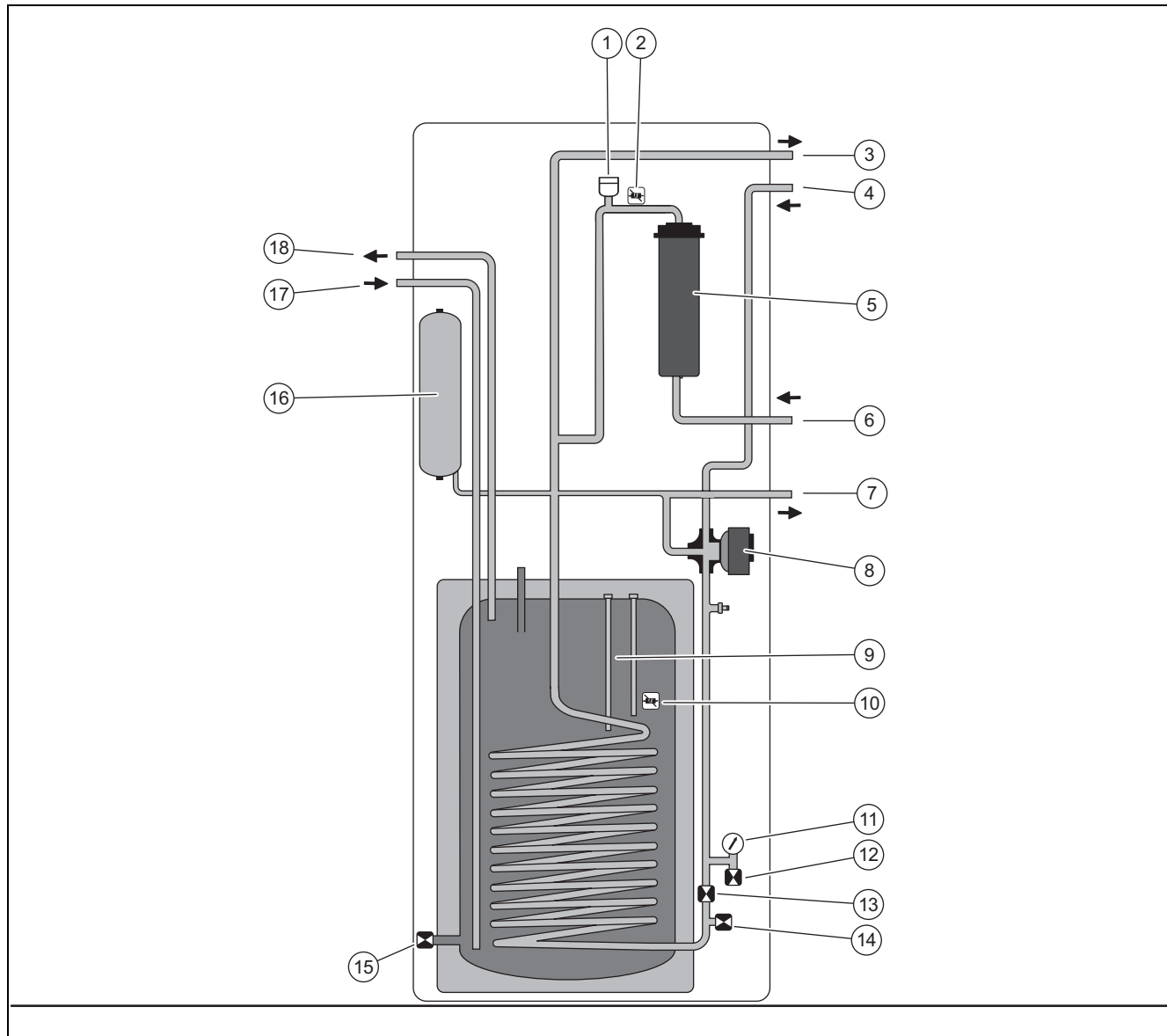

1	Automatic air vent	10	Cylinder temperature sensor
2	Flow temperature sensor: Electric back-up heater output	11	Manometer
3	Building circuit, flow	12	Filling/draining cock
4	Building circuit, return	13	Isolation valve
5	Back-up heater	14	Draining cock, heat pump and heating circuit
6	Heating flow from the outdoor unit	15	Domestic hot water cylinder's draining cock
7	Heating return to the outdoor unit	16	Diaphragm expansion vessel
8	Prioritising diverter valve	17	Cold water
9	Protection anode	18	Domestic hot water

B Wiring diagram

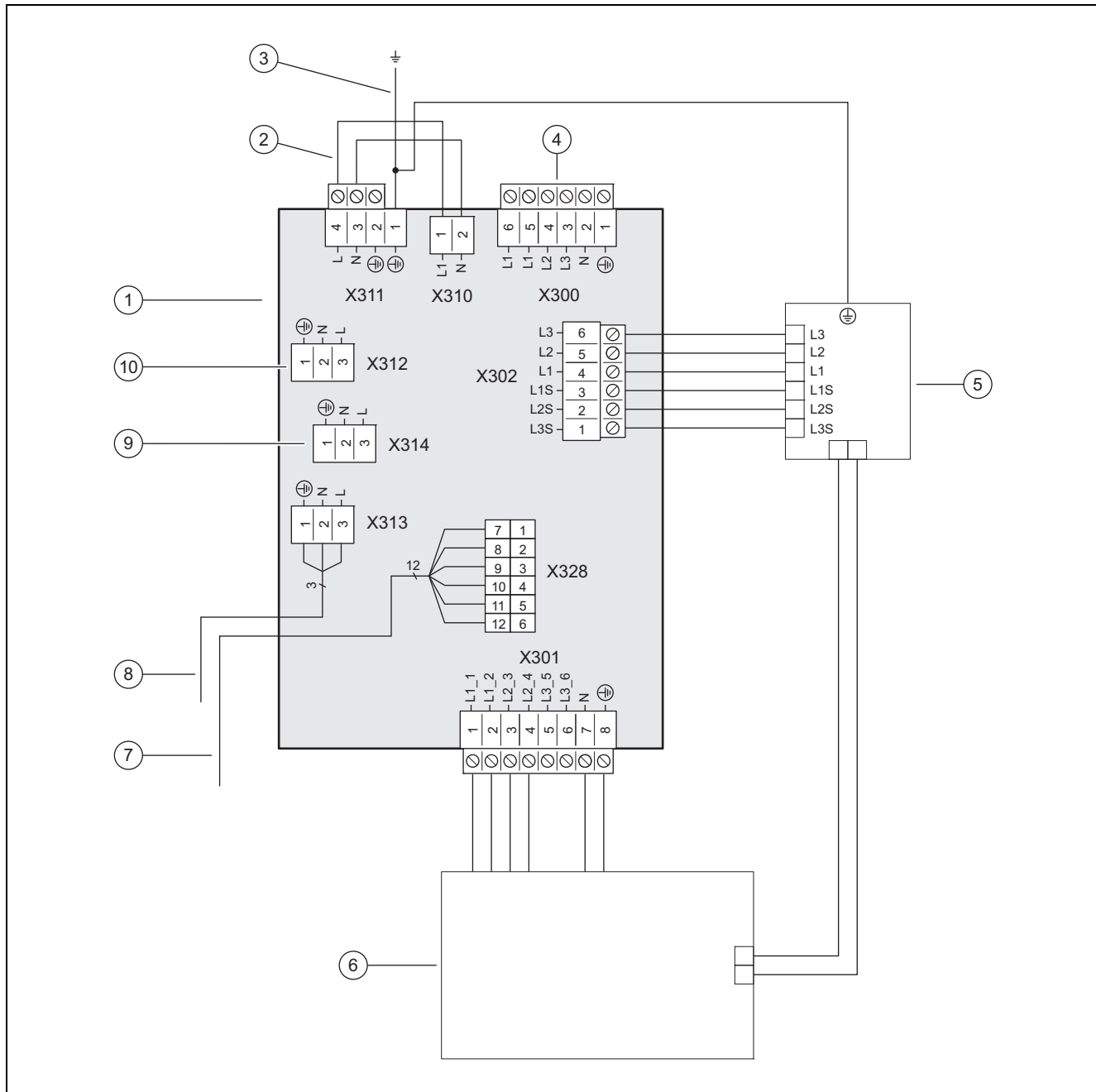

- | | |
|---|---|
| <p>1 Power supply PCB</p> <p>2 For single power supply: 230 V bridge between X311 and X310; for dual power supply: Replace the bridge at X311 with the 230 V connection</p> <p>3 Permanently installed protective conductor connection to the housing</p> <p>4 [X300] Power supply connection</p> <p>5 [X302] Safety cut-out</p> <p>6 [X301] Back-up heater</p> | <p>7 [X328] Data connection to the control PCB</p> <p>8 [X313] Power supply for the control PCB or the optional VR 70/VR 71 or the optional external current anode</p> <p>9 [X314] Power supply for the control PCB or the optional VR 70/VR 71 or the optional external current anode</p> <p>10 [X312] Power supply for the control PCB or the optional VR 70/VR 71 or the optional external current anode</p> |
|---|---|

C Control PCB

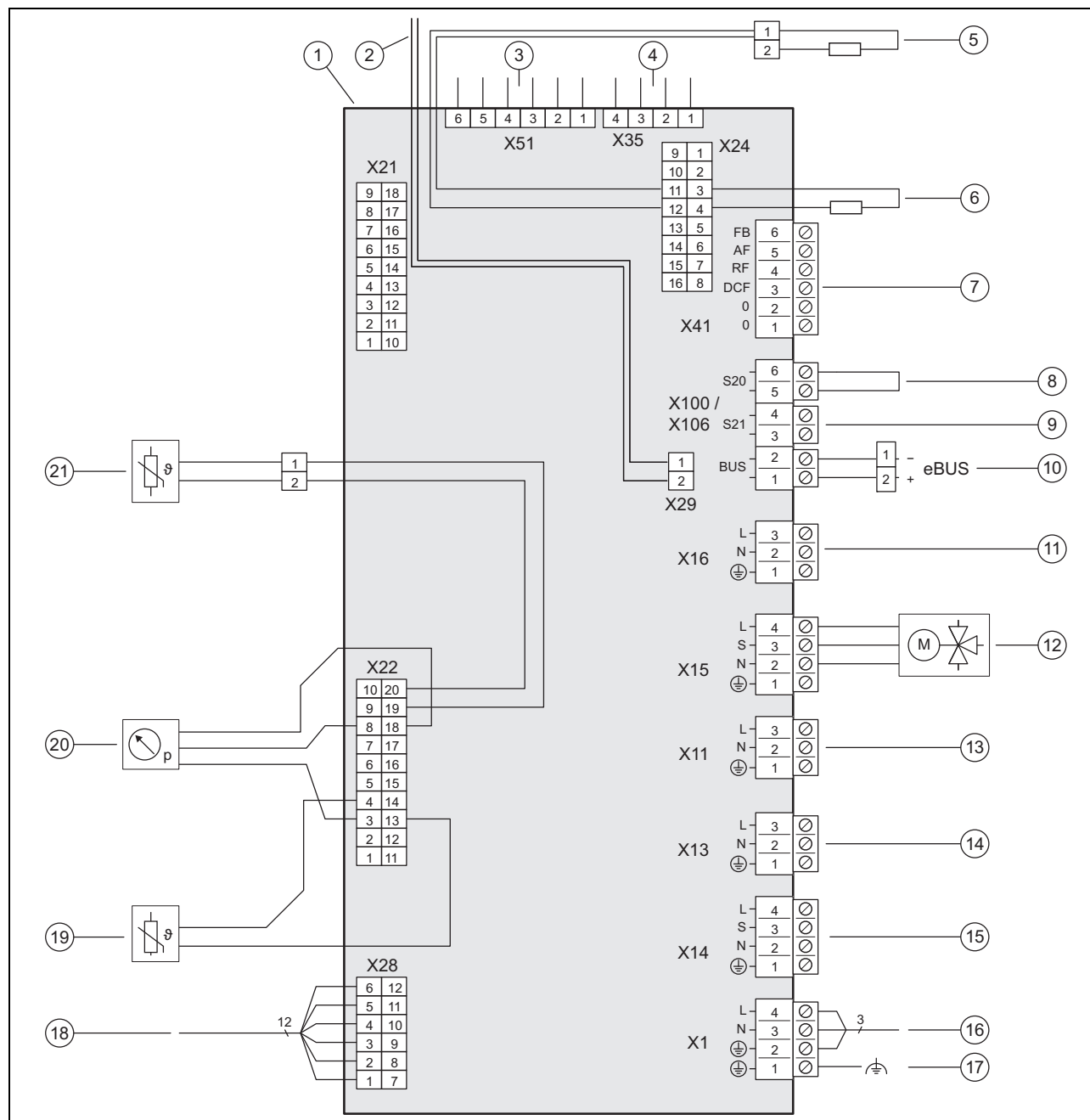

- | | | | |
|----|---|----|---|
| 1 | Control PCB | 11 | [X16] Optional: Accessory (intermediate heat exchanger pump) |
| 2 | [X29] eBUS bus connection for the installed system control | 12 | [X15] Internal prioritising diverter valve for heating circuit/cylinder charging |
| 3 | [X51] Display edge connector | 13 | [X11] Multi-function output 2: Domestic hot water circulation pump |
| 4 | [X35] Edge connector for optional external current anode | 14 | [X13] Multi-function output 1 |
| 5 | [X24] Coding resistor 3 | 15 | [X14] Multi-function output: External back-up heater/external prioritising diverter valve |
| 6 | [X24] Coding resistor 2 | 16 | [X1] 230 V supply for control PCB |
| 7 | [X41] Edge connector (outdoor temperature sensor, DCF, system temperature sensor, multi-function input) | 17 | [X1] Functional earth |
| 8 | [X106/S20] Limit thermostat | 18 | [X28] Data connection to the power supply PCB |
| 9 | [X106/S21] ESCO contact | 19 | [X22] Immersion heater flow temperature sensor |
| 10 | [X106/BUS] eBUS bus connection (outdoor unit, VRC 700, VR 70 / VR 71) | 20 | [X22] Optional: Accessory (building circuit pressure sensor for optional intermediate heat exchanger) |
| | | 21 | [X22] Domestic hot water cylinder temperature sensor |

D Basic connection diagram for the energy supply company lockout, shutdown via connection S21

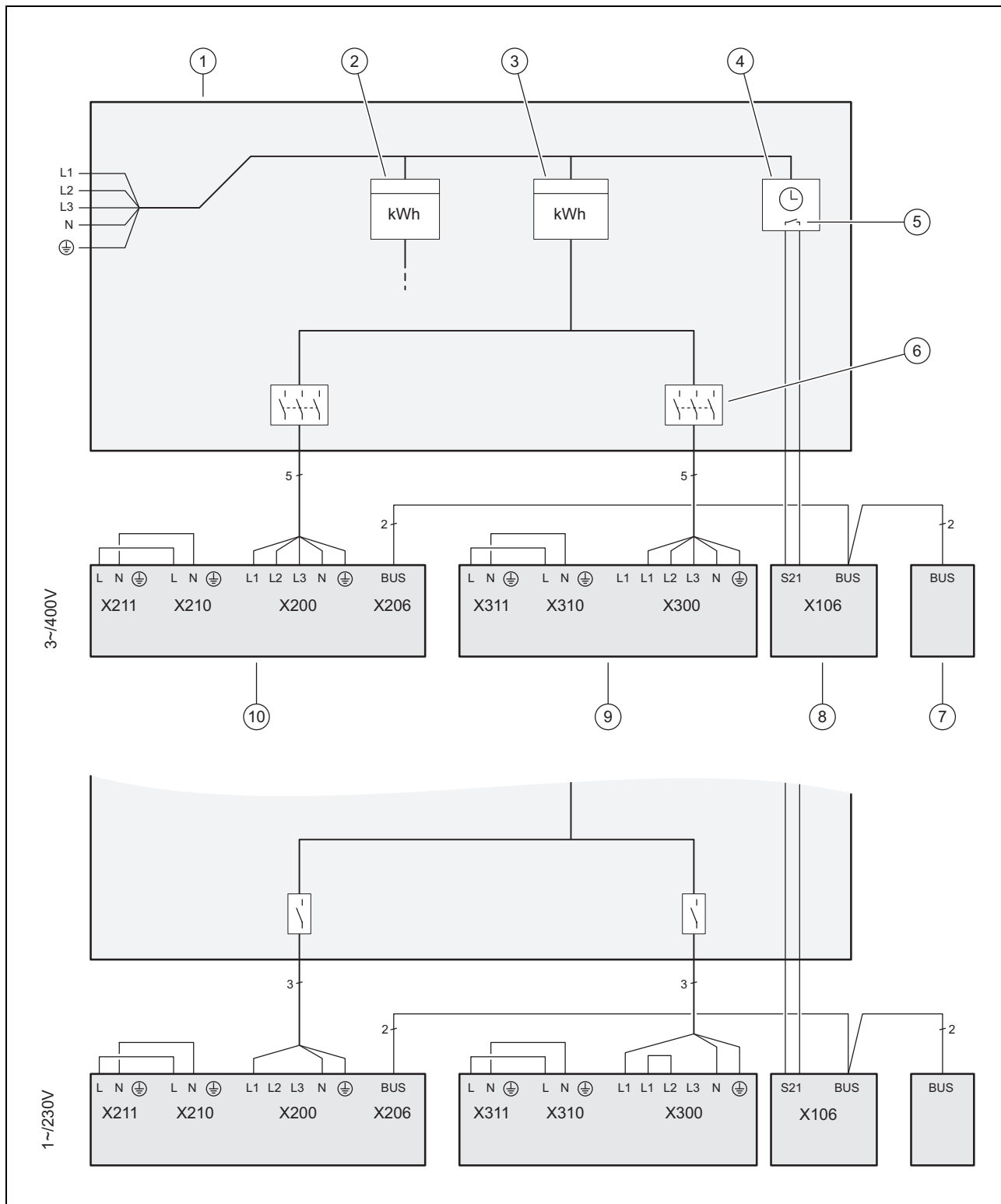

- | | | | |
|---|---|----|--------------------------------------|
| 1 | Meter/fuse box | 6 | Disconnector (circuit breaker, fuse) |
| 2 | Household electricity meter | 7 | System control |
| 3 | Heat pump electricity meter | 8 | Indoor unit, control PCB |
| 4 | Ripple control receiver | 9 | Indoor unit, power supply PCB |
| 5 | Potential-free normally open contact, for actuating S21, for the energy supply company lockout function | 10 | Outdoor unit, PCB INSTALLER BOARD |

Appendix

E Basic connection diagram for the energy supply company lockout, shutdown via partition

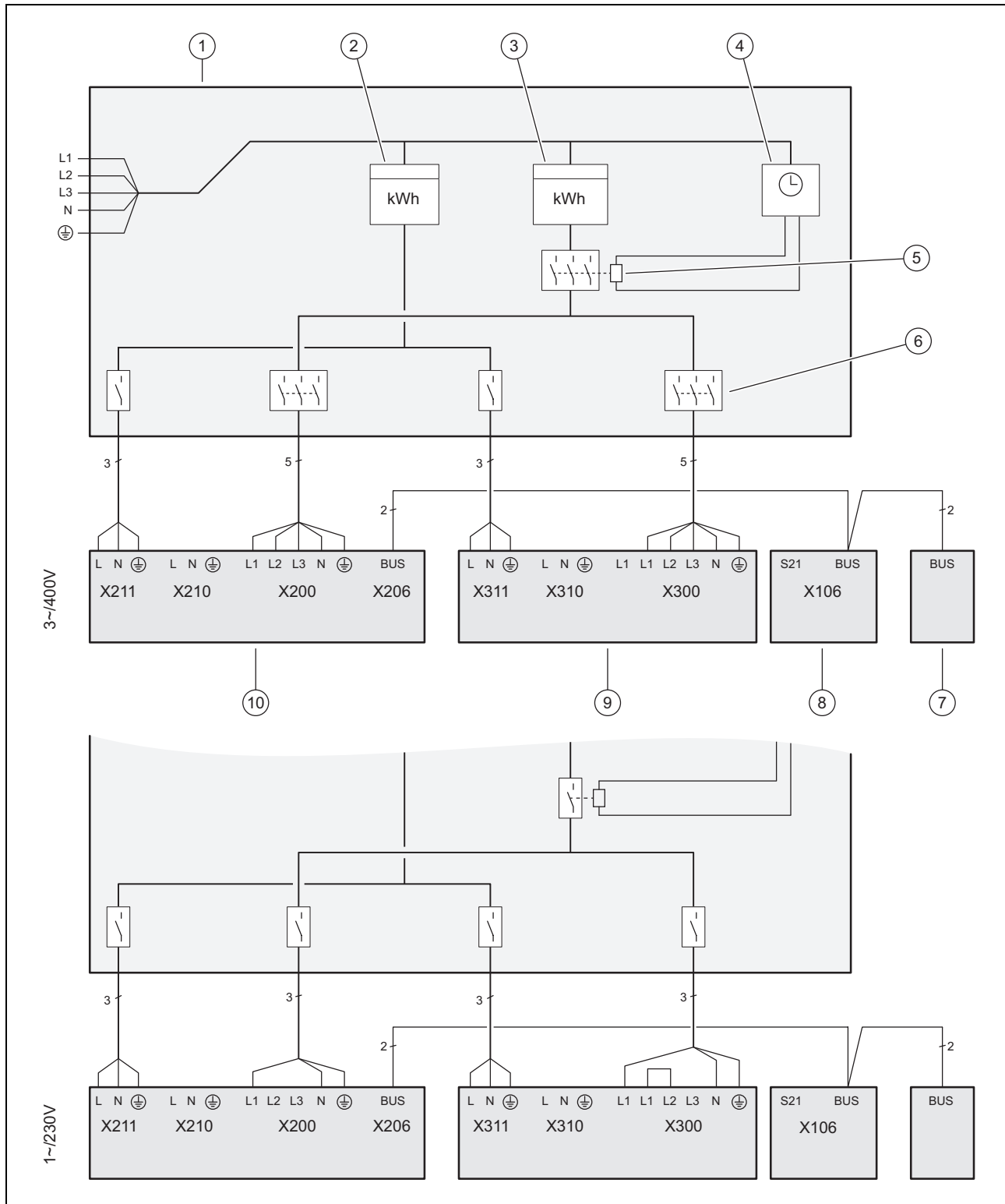

- | | | | |
|---|---|----|--------------------------------------|
| 1 | Meter/fuse box | 6 | Disconnecter (circuit breaker, fuse) |
| 2 | Household electricity meter | 7 | System control |
| 3 | Heat pump electricity meter | 8 | Indoor unit, control PCB |
| 4 | Ripple control receiver | 9 | Indoor unit, power supply PCB |
| 5 | Partition, for the energy supply company lockout function | 10 | Outdoor unit, PCB INSTALLER BOARD |

F Installer level overview

Setting level	Values		Unit	Increment, select, explanation	Factory setting	Setting
	Min.	Max.				
Installer level →						
Enter code	00	99		1 (competent person code 17)	17	
Installer level → Fault list →						
F.XX – F.XX ¹⁾	Current value					
Installer level → Test menu → Statistics →						
Compressor hours	Current value		h			
Compressor starts	Current value					
Build. pump hours	Current value		h			
Build. pump starts	Current value					
4-port valve hours	Current value		h			
4-port valve sw. ops	Current value					
Fan 1 operating hours	Current value		h			
Fan 1 starts	Current value					
Fan 2 operating hours	Current value		h			
Fan 2 starts	Current value					
EEV steps	Current value					
DHW PDV switch. ops	Current value					
Im. heater power cons.	Current value		kWh			
Im. heater op. hours	Current value		h			
Im. heater switch. ops	Current value					
No. switch. ops	Current value					
Installer level → Test menu → Check programmes →						
P.04 Heating mode				Select		
P.06 Purge building circuit				Select		
P.11 Cooling mode				Select		
P.12 De-icing				Select		
P.27 Immersion heater				Select		
P.29 High pressure				Select		
Installer level → Test menu → Sensor/actuator test →						
T.0.01 Building circuit pump power	0	100	%	5, off	0	
T.0.17 Fan 1	0	100	%	5	0	
T.0.18 Fan 2	0	100	%	5	0	
T.0.19 Condensate tray heater	Off	On		On, Off	Off	
T.0.20 4-port valve	Off	On		On, Off	Off	
T.0.21 Position: EEV	0	100	%	5	0	
T.0.23 Heating coil compressor	Off	On		On, Off	Off	
T.0.40 Flow temperature	-40	90	°C	0.1		
T.0.41 Return temperature	-40	90	°C	0.1		
¹⁾ See the overview of fault codes: Fault lists are only available, and can only be deleted, if faults have occurred. ²⁾ This parameter does not appear if a system control is connected. ³⁾ This parameter is only available in the products for Spain						

Appendix

Setting level	Values		Unit	Increment, select, explanation	Factory setting	Setting
	Min.	Max.				
T.0.42 Building circuit: Pressure	0	3	bar	0.1		
T.0.43 Building circuit: Flow rate	0	4000	l/h	1		
T.0.48 Air inlet temperature	-40	90	°C	0.1		
T.0.55 Compressor outlet temperature	-40	135	°C	0.1		
T.0.56 Compressor inlet temperature	-40	135	°C	0.1		
T.0.57 EEV outlet temperature	-40	90	°C			
T.0.59 Capacitor outlet temperature	-40	90	°C	0.1		
T.0.63 High pressure	0	31.9	bar (abs)	0.1		
T.0.64 Low pressure	0	8	bar (abs)	0.1		
T.0.67 High-pressure switch	Closed	Open		Closed, Open		
T.0.85 Evaporation temperature	-40	90	°C	0.1		
T.0.86 Condensation temperature	-40	70	°C	0.1		
T.0.87 Overheating target value	-40	90	K	0.1		
T.0.88 Overheating actual value	-40	90	K	0.1 to 20 K are normal operating parameters		
T.0.89 Subcooling target value	-40	90	K	0.1		
T.0.90 Subcooling actual value	-40	90	K	0.1		
T.0.93 Compressor speed	0	120	Rotation/s	1		
T.0.123 Temperature switch: Compressor outlet	Open	Closed		Open, closed		
T.1.02 DHW prioritising diverter valve	Heating	Domestic hot water		Heating, domestic hot water	Heating	
T.1.44 Cylinder temperature	-40	90	°C	0.1		
T.1.46 Lockout contact S20	Closed	Open		Closed, Open	Closed	
T.1.69 Outdoor temperature	-40	90	°C	0.1		
T.1.70 System temperature	-40	90	°C	0.1		
T.1.71 DCF status	Current value			No DCF signal Validate DCF signal Valid DCF signal		
T.1.72 Lockout contact S21	Closed	Open		Closed, Open	Open	
T.1.119 MO1 output	Off	On		Off, On	Off	
T.1.124 Safety cut-out immersion heater	Closed	Open		Closed, Open	Closed	
T.1.125 MPI input	Current value					
T.1.126 MO2 output	Off	On		Off, On	Off	
T.1.127 MO3 output	Off	On		Off, On	Off	
Installer level → Configuration →						
Language	Current language			Languages available for selection	02 English	
Contact details → Telephone number	Phone number			0-9		
Heat curve ²⁾	0.4	4.0		0.1		
Summer sw.-off temp. ²⁾	10	90	°C	1		
Heating biv. point ²⁾	-30	+20	°C	1		
¹⁾ See the overview of fault codes: Fault lists are only available, and can only be deleted, if faults have occurred. ²⁾ This parameter does not appear if a system control is connected. ³⁾ This parameter is only available in the products for Spain						

Setting level	Values		Unit	Increment, select, explanation	Factory setting	Setting
	Min.	Max.				
DHW bivalence point ²⁾	-20	+20	°C	1		
Heating alt. point ²⁾	-20	+40	°C	Off 1		
Max. flow temperature ²⁾	15	90	°C	1		
Min. flow temperature ²⁾	15	90	°C	1		
Heating mode activ. ²⁾				On Off		
DHW activation ²⁾				On Off		
Cyl. charg. hysteresis ²⁾	3	20	K	1		
Immers. heater mode ²⁾				Off Heating+DHW Heating Domestic hot water		
Limp home mode ²⁾				Off Heating Domestic hot water Heating+domestic hot water		
Cooling target flow ²⁾	7	24	°C	1		
MO relay				None Fault signal Ext. immersion heater DHW 3WV		
Compr.start heat. from	-999	9	°min	1	-60	
Compr.start cool. from	0	999	°min	1	60	
Compressor hyster. Heat.	0	15	K	Applies for heating mode only: 1	7	
Compressor hyster. Cool.	0	15	K	Applies for cooling mode only: 1	5	
Max. rem. feed head	200	900	mbar	10	900	
DHW mode	0 = ECO	2 = Balance		0 = ECO, 1 = Normal, 2 = Balance	0	
Max. anti-cycl. time	0	9	h	1	5	
Conf. heat. build. pump	50	100	% PWM	Auto	Auto	
Conf. cool. build. pump	50	100	% PWM	Auto	Auto	
Conf. DHW build. pump	50	100	% PWM	Auto	65	
Reset anti-cycl. time → Anti-cycl. time after pow. supp. switch-on	0	120	min	1	0	
Im. heater power supp.	230	400	V	230, 400		
Im. heater outp. range	External	9	kW	5 kW and 7 kW: 230 V and 400 V: 1-6: 1 kW-6 kW 12 kW: 230 V 1-6: 1 kW-6 kW 12 kW: 400 V 1-9: 1 kW-9 kW	6 or 9	
¹⁾ See the overview of fault codes: Fault lists are only available, and can only be deleted, if faults have occurred. ²⁾ This parameter does not appear if a system control is connected. ³⁾ This parameter is only available in the products for Spain						

Appendix

Setting level	Values		Unit	Increment, select, explanation	Factory setting	Setting
	Min.	Max.				
Compr. current limit				1 5–7 kW: 13–16 A 12 kW: 20–25 A		
Fan boost ³⁾	52	70		1	70	
Compr. noise reduct. ²⁾	40	60	%	1	40	
Only for products with cooling: Cooling technology	None	Active cooling		None, active cooling	None	
Intermediate heat exchanger	Yes	no		Yes, No		
Software version	Current value of the control PCB (HMU indoor unit xxxx, HMU outdoor unit xxxx) and the display (AI xxxx)			xxxx.xx.xx		
Installer level → Resets →						
Statistics → Reset statistics?				Yes, No	No	
Maintenance messages → Reset maintenance message				Yes, No	No	
High-pressure switch → Reset fault?				Yes, No	No	
Factory settings → Restore factory settings				Yes, No	No	
Screed drying ²⁾				Off, 1–29	Off	
Installer level → Start inst. assistant →						
Language				Languages available for selection	02 English	
Syst. control avail.?	Yes	no		Yes, No		
Im. heater power supp.	230 V	400 V				
Im. heater outp. range	External	9	kW	5 kW and 7 kW: 230 V and 400 V: 1–6: 1 kW–6 kW 12 kW: 230 V 1–6: 1 kW–6 kW 12 kW: 400 V: 1–9: 1 kW–9 kW	6 or 9	
Cooling technology	No cooling	Active cooling				
Compr. current limit	13	25	A	1 5–7 kW: 13–16 A 12 kW: 20–25 A		
MO relay				None, fault signal, ext. immersion heater, DHW 3WV	None	
Intermediate heat exchanger	Yes	no		Yes, No		
Check program: Purge building circuit	Yes	no		Yes, No	no	
Contact details Telephone number	Phone number			0–9	Empty	
End the installation assistant?				Yes, back		
¹⁾ See the overview of fault codes: Fault lists are only available, and can only be deleted, if faults have occurred. ²⁾ This parameter does not appear if a system control is connected. ³⁾ This parameter is only available in the products for Spain						

G Status codes

Statuscode	Meaning
Status external current anode	Anode not connected, Anode OK, Anode Fault
S.34 Heating mode: Frost protection	If the measured outdoor temperature falls below XX °C, the temperature of the heating circuit's flow and return is monitored. If the temperature difference exceeds the set value, the pump and compressor are started without a heat demand.
S.100 Standby	There is no heat demand or cooling demand. Standby 0: Outdoor unit. Standby 1: Indoor unit
S.101 Heating: Compressor shutdown	The heat demand is met, the demand is ended by the system control and the heat deficit is offset. The compressor is switched off.
S.102 Heating: Compressor blocked	The compressor is blocked for heating mode because the heat pump is outside of its operating limits.
S.103 Heating: Prerun	The start conditions for the compressor in heating mode are checked. Start the other actuators for heating mode.
S.104 Heating: Compressor active	The compressor works in order to meet the heat demand.
S.107 Heating: Overrun	The heat demand is met, the compressor is switched off. The pump and fan overrun.
S.111 Cooling: Compressor shutdown	The cooling demand is met, the demand is ended by the system control. The compressor is switched off.
S.112 Cooling: Compressor blocked	The compressor is blocked for cooling mode because the heat pump is outside of its operating limits.
S.113 Cooling: Compressor mode prerun	The start conditions for the compressor in cooling mode are checked. Start the other actuators for cooling mode.
S.114 Cooling: Compressor active	The compressor works in order to meet the cooling demand.
S.117 Cooling: Compressor mode overrun	The cooling demand is met, the compressor is switched off. The pump and fan overrun.
S.125 Heating: Immersion heater active	The immersion heater is used in heating mode.
S.132 Domestic hot water: Compressor blocked	The compressor is blocked for domestic hot water mode because the heat pump is outside of the operating limits.
S.133 Domestic hot water: Prerun	The start conditions for the compressor in domestic hot water mode are checked. Start the other actuators for domestic hot water mode.
S.134 Domestic hot water: Compressor active	The compressor works in order to meet the domestic hot water demand.
S.135 Domestic hot water: Immersion heater active	The immersion heater is used in domestic hot water mode.
S.137 Domestic hot water: Overrun	The domestic hot water demand is met, the compressor is switched off. The pump and fan overrun.
S.141 Heating: Immersion heater shutdown	The heat demand is met, the immersion heater is switched off.
S.142 Heating: Immersion heater blocked	The immersion heater is blocked for heating mode.
S.151 Domestic hot water: Immersion heater shutdown	The domestic hot water demand is met, the immersion heater is switched off.
S.152 Domestic hot water: Immersion heater blocked	The immersion heater is blocked for domestic hot water mode.
S.173 Anti-cycling time for the energy supply company	The mains voltage supply is interrupted by the energy supply company. The maximum anti-cycling time is set in the configuration.
S.202 Check programme: Purging of building circuit active	The building circuit pump is actuated in cyclical intervals, alternately in heating mode and domestic hot water mode.
S.203 Actuator test active	The sensor and actuator test is currently operating.
S.212 Connection fault: Control not recognised	System control was previously detected but the connection is broken. Check the eBUS connection to the system control. It can only be operated with the heat pump's additional functions.
S.240 Compr. oil temp. too low, environment too cold	The compressor heating is switched on. The unit does not start up.
S.252 Fan unit 1: Fan blocked	If the fan speed is 0 rpm, the heat pump is switched off for 15 minutes and then restarted. If the fan does not start up after four unsuccessful restarts, the heat pump is switched off and the fault message F.718 is displayed.
S.255 Fan unit 1: Air inlet temp. too high	The compressor does not start because the outdoor temperature at the fan is above the operating limits. Heating mode: > 43 °C. Domestic hot water mode: > 43 °C. Cooling mode: > 46 °C.

Appendix

Statuscode	Meaning
S.256 Fan unit 1: Air inlet temp. too low	The compressor does not start because the outdoor temperature at the fan is below the operating limits. Heating mode: < -20 °C. Domestic hot water mode: < -20 °C. Cooling mode: < 15 °C.
S.260 Fan unit 2: Fan blocked	If the fan speed is 0 rpm, the heat pump is switched off for 15 minutes and then restarted. If the fan does not start up after four unsuccessful restarts, the heat pump is switched off and the fault message F.785 is displayed.
S.272 Building circuit: Remaining feed head limit active	The remaining feed head that is set under the configuration is reached.
S.273 Building circuit: Flow temperature too low	The flow temperature that is measured in the building circuit is below the operating limits.
S.275 Building circuit: Flow rate too low	Building circuit pump defective. All consumers in the heating system are closed. The values fall below the specific minimum volume flows. Check that the dirt filter is permeable. Check the stopcocks and thermostatic valves. Ensure that the flow rate is at least 35% of the nominal flow rate. Check that the building circuit pump functions correctly.
S.276 Building circuit: Lock-out contact S20 open	Contact S20 is open at the heat pump's main PCB. Incorrect limit thermostat setting. Flow temperature sensor (heat pump, gas-fired boiler, system sensor) measures values that deviate downwards. Adjust the maximum flow temperature for the direct heating circuit via the system control (observe the upper switch-off threshold for the boilers). Adjust the set value for the limit thermostat. Check the sensor values
S.277 Building circuit: Pump fault	If the building circuit pump is inactive, the heat pump is switched off for 10 minutes and is then restarted. If the building circuit pump does not start up after three unsuccessful restarts, the heat pump is switched off and the fault message F.788 is displayed.
S.280 Freq. converter fault: Compressor	The compressor motor or wiring is defective.
S.281 Freq. converter fault: Mains voltage	There is overvoltage or undervoltage.
S.282 Freq. converter fault: Overheating	If the cooling of the frequency inverter is not sufficient, the heat pump is switched off for one hour and then restarted again. If the cooling is not sufficient after three unsuccessful restarts, the heat pump is switched off and the fault message F.819 is displayed.
S.283 De-icing time too long	If the de-icing takes longer than 15 minutes, the heat pump is restarted. If the time for the de-icing is still not sufficient after three unsuccessful restarts, the heat pump is switched off and the fault message F.741 is displayed. ▶ Check whether sufficient thermal energy is available from the building circuit.
S.284 De-icing flow temperature too low	If the flow temperature is below 5 °C, the heat pump is restarted. If the flow temperature is still not sufficient after three unsuccessful restarts, the heat pump is switched off and the fault message F.741 is displayed. ▶ Check whether sufficient thermal energy is available from the building circuit.
S.285 Compressor outlet temperature too low	Compressor outlet temperature is too low
S.286 Hot gas temperature switch open	If the hot gas temperature is above 119 °C +5 K, the heat pump is switched off for one hour and then restarted again. If the hot gas temperature has not fallen after three unsuccessful restarts, the heat pump is switched off and the fault message F.823 is displayed.
S.287 Fan 1: Wind	Before starting, the fan rotates at a speed of 50 rpm or higher. This may be caused by a strong outside wind.
S.288 Fan 2: Wind	Before starting, the fan rotates at a speed of 50 rpm or higher. This may be caused by a strong outside wind.
S.289 Current limit active	The outdoor unit's power consumption is reduced, the compressor speed is reduced. The compressor's operating current exceeds the limit value that is set under the configuration. (for 3 kW, 5 kW, 7 kW units: <16 A; for 10 kW, 12 kW units: <25 A)
S.290 Switch-on delay active	The compressor's switch-on delay is active.
S.302 High-pressure switch open	If the pressure in the refrigerant circuit exceeds the operating limit, the heat pump is switched off for 15 minutes and is then restarted again. If the pressure remains too high after four unsuccessful restarts, the fault message F.731 is displayed.
S.303 Compressor outlet temperature too high	The operating characteristics have been exited. The heat pump is restarted.
S.304 Evaporation temperature too low	The operating characteristics have been exited. The heat pump is restarted.
S.305 Condensation temperature too low	The operating characteristics have been exited. The heat pump is restarted.
S.306 Evaporation temperature too high	The operating characteristics have been exited. The heat pump is restarted.
S.308 Condensation temperature too high	The operating characteristics have been exited. The heat pump is restarted.
S.312 Building circuit: Return temperature too low	Return temperature in the building circuit too low for compressor to start. Heating: Return temperature < 5 °C. Cooling: Return temperature < 10 °C. Cooling: Check that the 4-port diverter valve works correctly.

Statuscode	Meaning
S.314 Building circuit: Return temperature too high	Return temperature in the building circuit too high for the compressor to start. Heating: Return temperature > 56 °C. Cooling: Return temperature > 35 °C. Cooling: Check that the 4-port diverter valve works correctly. Check the sensors.
S.351 Immersion heater: Flow temp. too high	The flow temperature at the immersion heater is too high. Flow temperature > 75 °C. The heat pump is switched off.
S.516 De-icing mode active	The heat pump de-ices the outdoor unit's heat exchanger. The heating mode is interrupted. The maximum de-icing time is 16 minutes.
S.575 Frequency converter: Internal fault	An internal electronics fault is present on the outdoor unit's inverter PCB. If this occurs three times, fault message F.752 appears.
S.581 Connection fault: Frequency converter not recognised	Missing communication between the frequency converter and the outdoor unit's PCB. After this occurs three times, fault message F.753 appears.
S.590 Fault: 4-port valve position not correct	The 4-port diverter valve does not move fully to the heating or cooling position.

H Maintenance messages

Code	Meaning	Cause	Remedy
M.23	Status external current anode	– External current anode not recognised	– If required, check for a cable break
M.32	Building circuit: Pressure low	– Pressure loss in the building circuit due to leakages or air pockets – Building circuit pressure sensor is defective	– Check the building circuit for leaks, top up with heating water and purge – Check the plug contact on the PCB and on the cable harness; check that the pressure sensor is working correctly and, if required, replace the pressure sensor
M.200	Building circuit 2: Low pressure	– Pressure loss in the building circuit due to leakages or air pockets – Building circuit pressure sensor is defective	– Check the building circuit for leaks, top up with heating water and purge – Check the plug contact on the PCB and on the cable harness; check that the pressure sensor is working correctly and, if required, replace the pressure sensor
M.201	Sensor fault: Cylinder temperature	– Cylinder temperature sensor defective	– Check the plug contact on the PCB and on the cable harness; check that the sensor is working correctly and, if required, replace the sensor
M.202	Sensor fault: System temperature	– System temperature sensor defective	– Check the plug contact on the PCB and on the cable harness; check that the sensor is working correctly and, if required, replace the sensor
M.203	Connection fault: Disp. not recognised	– Display defective – Display not connected	– Check the quality of the plug contact on the PCB and on the cable harness – Replace the display, if required

I Comfort protection mode

Code	Meaning	Description	Remedy
200	Sensor fault: Temp. air inlet	Still possible to operate with existing, functional outdoor temperature sensor	Replace the air inlet sensor

Appendix

J Fault codes

Code	Meaning	Cause	Remedy
F.022	Water pressure too low	<ul style="list-style-type: none"> - Pressure loss in the building circuit due to leakages or air pockets - Building circuit pressure sensor defective 	<ul style="list-style-type: none"> - Check the building circuit for leaks - Top up with water, purge - Check the quality of the plug contact on the PCB and on the cable harness - Check that the pressure sensor is working correctly - Replace the pressure sensor
F.042	Fault: Coding resistor	<ul style="list-style-type: none"> - Coding resistor damaged or not set 	<ul style="list-style-type: none"> - Check that the coding resistor is positioned correctly and, if required, replace it.
F.073	Sensor fault: Build. circ. pressure	<ul style="list-style-type: none"> - The sensor is not connected or the sensor input has short-circuited 	<ul style="list-style-type: none"> - Check and, if required, replace the sensor - Replace the cable harness
F.094	Fault: Vortex	<ul style="list-style-type: none"> - Volume flow sensor not connected or sensor input has short-circuited 	<ul style="list-style-type: none"> - Check and, if required, replace the sensor - Replace the cable harness
F.103	Fault: Spare part ident.	<ul style="list-style-type: none"> - Incorrect control PCB installed on the outdoor unit 	<ul style="list-style-type: none"> - Installing the correct PCB
F.514	Sensor fault: Compr. inlet temp.	<ul style="list-style-type: none"> - The sensor is not connected or the sensor input has short-circuited 	<ul style="list-style-type: none"> - Check and, if required, replace the sensor - Replace the cable harness
F.517	Sensor fault: Compr. outlet temp.	<ul style="list-style-type: none"> - The sensor is not connected or the sensor input has short-circuited 	<ul style="list-style-type: none"> - Check and, if required, replace the sensor - Replace the cable harness
F.519	Sensor fault: Building circuit re- turn temp.	<ul style="list-style-type: none"> - The sensor is not connected or the sensor input has short-circuited 	<ul style="list-style-type: none"> - Check and, if required, replace the sensor - Replace the cable harness
F.520	Sensor fault: Building circuit flow temp.	<ul style="list-style-type: none"> - The sensor is not connected or the sensor input has short-circuited 	<ul style="list-style-type: none"> - Check and, if required, replace the sensor - Replace the cable harness
F.526	Sensor fault: EEV outlet temp.	<ul style="list-style-type: none"> - The sensor is not connected or the sensor input has short-circuited 	<ul style="list-style-type: none"> - Check and, if required, replace the sensor - Replace the cable harness
F.546	Sensor fault: High pressure	<ul style="list-style-type: none"> - The sensor is not connected or the sensor input has short-circuited 	<ul style="list-style-type: none"> - Check the sensor (e.g. using an installation aid), and replace if necessary - Replace the cable harness
F.582	Fault: EEV	<ul style="list-style-type: none"> - EEV is not connected correctly or there is a cable break to the coil 	<ul style="list-style-type: none"> - Check the plug connections and, if required, replace the coil from the EEV
F.585	Sensor fault: Capac. outlet temp.	<ul style="list-style-type: none"> - The sensor is not connected or the sensor input has short-circuited 	<ul style="list-style-type: none"> - Check and, if required, replace the sensor - Replace the cable harness
F.703	Sensor fault: Low pressure	<ul style="list-style-type: none"> - The sensor is not connected or the sensor input has short-circuited 	<ul style="list-style-type: none"> - Checking the sensor (e.g. using an installation aid), and replacing it if necessary - Replace the cable harness
F.718	Fan unit 1: Fan blocked	<ul style="list-style-type: none"> - There is no confirmation signal stating that the fan is rotating 	<ul style="list-style-type: none"> - Check the air route and, if required, remove any blockages
F.729	Compressor outlet temperature too low	<ul style="list-style-type: none"> - The compressor outlet temperature is lower than 0 °C for more than 10 minutes or the compressor outlet temperature is lower than -10 °C even though the heat pump is in the operating characteristics. 	<ul style="list-style-type: none"> - Checking the high-pressure sensor - Checking that the EEV is working correctly - Checking for condensate leaking from the temperature sensor (undercooling) - Check whether the 4-port diverter valve is in the intermediate position - Checking the refrigerant volume for overfilling

Code	Meaning	Cause	Remedy
F.731	High-pressure switch open	<ul style="list-style-type: none"> - Refrigerant pressure too high. The integrated high-pressure switch in the outdoor unit has tripped at 41.5 bar (g) or 42.5 bar (abs) - Insufficient energy output via the condenser 	<ul style="list-style-type: none"> - Purging the building circuit - Too low a volume flow as a result of closing single room controls in an underfloor heating system - Check that the dirt filter that is in place is permeable - Refrigerant flow rate too low (e.g. electronic expansion valve defective, 4-port diverter valve is mechanically blocked, filter is blocked). Inform customer service. - Cooling mode: Check the fan unit for dirt - Check the high-pressure switch and high-pressure sensor - Reset the high-pressure switch and carry out a manual reset on the product.
F.732	Compressor outlet temperature too high	<p>The compressor outlet temperature is above 110 °C:</p> <ul style="list-style-type: none"> - Application limits exceeded - EEV does not work or does not open correctly - Refrigerant volume too low (frequent defrosting due to extremely low evaporation temperatures) 	<ul style="list-style-type: none"> - Check the compressor inlet sensor and outlet sensor - Check the compressor outlet temperature sensor (TT135) - Check the EEV (does the EEV move to the limit stop? Use the sensor/actuator test) - Check the refrigerant volume (see Technical data) - Carry out a leak-tightness test - Check whether the service valves on the outdoor unit are open.
F.733	Evaporation temperature too low	<ul style="list-style-type: none"> - Insufficient air volume flow through the outdoor unit's heat exchanger (heating mode) leads to an insufficient energy input in the environment circuit (heating mode) or building circuit (cooling mode) - Refrigerant volume too low 	<ul style="list-style-type: none"> - If the building circuit contains thermostatic valves, check that they are suitable for cooling mode (check volume flow in cooling mode) - Check the fan unit for dirt - Check the EEV (does the EEV move to the limit stop? Use the sensor/actuator test) - Check the compressor inlet sensor - Check the refrigerant volume
F.734	Condensation temperature too low	<ul style="list-style-type: none"> - The temperature in the heating circuit is too low, outside of the operating characteristics - Refrigerant volume too low 	<ul style="list-style-type: none"> - Check the EEV (does the EEV move to the limit stop? Use the sensor/actuator test) - Check the compressor inlet sensor - Check the refrigerant filling volume (see technical data) - Check whether the 4-port diverter valve is in an intermediate position and is not correctly switched - Check the high-pressure sensor - Check the pressure sensor in the heating circuit
F.735	Evaporation temperature too high	<ul style="list-style-type: none"> - Temperature in the environment circuit (heating mode) or building circuit (cooling mode) too high for compressor operation - Feed-in of external heat into the environment circuit due to increased fan speed 	<ul style="list-style-type: none"> - Check the system temperatures - Check the refrigerant filling volume for overfilling - Check the EEV (does the EEV move to the limit stop? Use sensor/actuator test) - Check the sensor for the evaporation temperature (depending on the position of the 4-port diverter valve) - Check the volume flow in cooling mode - Check the air volume flow in heating mode

Appendix

Code	Meaning	Cause	Remedy
F.737	Condensation temperature too high	<ul style="list-style-type: none"> - Temperature in the environment circuit (cooling mode) or building circuit (heating mode) too high for compressor operation - Feed-in of external heat into the building circuit - Refrigerant circuit overfilled - Insufficient flow rate in the building circuit 	<ul style="list-style-type: none"> - Reduce or stop the external heat that is entering - Check the back-up heater (heats up even though it is off in the sensor/actuator test?) - Check the EEV (does the EEV move to the limit stop? Use the sensor/actuator test) - Check the compressor outlet sensor, compressor outlet temperature sensor (TT135) and high-pressure sensor - Check the refrigerant filling volume for overfilling - Check whether the service valves on the outdoor unit are open. - Check the air volume flow in cooling mode for sufficient flow rate - Checking the heating pump - Check the building circuit flow rate
F.741	Building circuit: Return temp. too low	<ul style="list-style-type: none"> - During the de-icing, the return temperature falls below 13 °C 	<ul style="list-style-type: none"> - Ensure the minimum installation volume is maintained; if required, install a series return cylinder - The fault message is displayed until the return temperature increases to above 20 °C. - Activate the electric back-up heater in the product's control panel and in the system control in order to increase the return temperature. The compressor is blocked while the fault message is present.
F.752	Fault: Frequency converter	<ul style="list-style-type: none"> - Internal electronics fault on the inverter PCB - Mains voltage outside of 70 V–282 V 	<ul style="list-style-type: none"> - Check the integrity of the power supply cables and compressor connection cables The plugs must audibly click into place. - Check the cable - Check the mains voltage The mains voltage must be between 195 V and 253 V. - Check the phases - Replace the frequency converter, if required
F.753	Connection fault: Freq. conv. n.recogn.	<ul style="list-style-type: none"> - Missing communication between the frequency converter and the outdoor unit's control PCB 	<ul style="list-style-type: none"> - Check the integrity of the cable harness and plug connection and, if required, replace them - Check the frequency converter by actuating the compressor safety relay - Read the assigned parameters for the frequency converter and check whether values are displayed
F.755	Fault: 4-port valve position not correct	<ul style="list-style-type: none"> - Incorrect position of the 4-port diverter valve. If, in heating mode, the flow temperature is lower than the return temperature in the building circuit. - The temperature sensor in the electronic expansion valve environment circuit displays an incorrect temperature. 	<ul style="list-style-type: none"> - Check the 4-port diverter valve (is an audible switching available? Use the sensor/actuator test) - Check that the coil is positioned correctly on the 4-port valve - Check the cable harness and plug connections - Check the temperature sensor in the electronic expansion valve environment circuit
F.774	Sensor fault: Air inlet temp.	<ul style="list-style-type: none"> - The sensor is not connected or the sensor input has short-circuited 	<ul style="list-style-type: none"> - Check and, if required, replace the sensor - Replace the cable harness

Code	Meaning	Cause	Remedy
F.785	Fan unit 2: Fan blocked	<ul style="list-style-type: none"> - There is no confirmation signal stating that the fan is rotating 	<ul style="list-style-type: none"> - Check the air route and, if required, remove any blockages
F.788	Building circuit: Pump fault	<ul style="list-style-type: none"> - The electronics system of the high-efficiency pump has detected a fault (e.g. dry running, blockage, overvoltage, undervoltage) and has switched off and locked the pump. 	<ul style="list-style-type: none"> - Switch the heat pump off for at least 30 seconds (no current) - Check the quality of the plug contact on the PCB - Check that the pump functions correctly - Purging the building circuit - Check that the dirt filter that is in place is permeable
F.817	Freq. converter fault: Compressor	<ul style="list-style-type: none"> - Defect in the compressor (e.g. short circuit) - Defect in the frequency converter - Connection cable to the compressor is defective or loose 	<ul style="list-style-type: none"> - Measure the winding resistance in the compressor - Measure the frequency converter output between the three phases, (it must be > 1 kΩ) - Check the cable harness and plug connections
F.818	Freq. converter fault: Mains voltage	<ul style="list-style-type: none"> - Incorrect mains voltage for operating the frequency converter - Shutdown via the energy supply company 	<ul style="list-style-type: none"> - Measure and, if required, correct the mains voltage <p>The mains voltage must be between 195 V and 253 V.</p>
F.819	Freq. converter fault: Overheating	<ul style="list-style-type: none"> - Internal overheating of the frequency converter 	<ul style="list-style-type: none"> - Allow the frequency converter to cool and restart the product - Check the frequency converter's air route - Check that the fan is working correctly - The maximum environmental temperature of the outdoor unit (46 °C) has been exceeded.
F.820	Connection fault: Building circuit pump	<ul style="list-style-type: none"> - Pump does not report any signal back to the heat pump 	<ul style="list-style-type: none"> - Check the cable to the pump for defects and, if required, replace it - Replace the pump
F.821	Sensor fault: Immers. heater flow temp.	<ul style="list-style-type: none"> - The sensor is not connected or the sensor input has short-circuited - Both of the flow temperature sensors in the heat pump are defective 	<ul style="list-style-type: none"> - Check and, if required, replace the sensor - Replace the cable harness
F.823	Hot gas temperature switch open	<ul style="list-style-type: none"> - The hot gas thermostat shuts down the heat pump if the temperature in the refrigerant circuit is too high. Following a waiting period, the heat pump attempts to start once more. After three failed start attempts in succession, a fault message is displayed. - Max. refrigerant circuit temperature: 110 °C - Waiting period: 5 mins (after it first occurs) - Waiting period: 30 mins (after it occurs a second time and any other time after that) - The fault counter is reset if both of the following conditions are met: <ul style="list-style-type: none"> - Heat requirement without switching off prematurely - 60 mins uninterrupted operation 	<ul style="list-style-type: none"> - Check the EEV - Replace the dirt filter in the refrigeration circuit, if required

Appendix

Code	Meaning	Cause	Remedy
F.824	Building circuit 2: Pressure too low Note Can only occur in conjunction with an installed and activated intermediate heat exchanger set. Fault refers to the outdoor unit's brine pressure sensor.	<ul style="list-style-type: none"> - Pressure loss in the building circuit due to leakages or air pockets - Building circuit pressure sensor defective 	<ul style="list-style-type: none"> - Check the building circuit for leaks - Top up with water, purge - Check the quality of the plug contact on the PCB and on the cable harness - Check that the pressure sensor is working correctly - Replace the pressure sensor
F.825	Sensor fault: Capac. inlet temp.	<ul style="list-style-type: none"> - Refrigerant circuit temperature sensor (vapour-forming) not connected or the sensor input has short-circuited 	<ul style="list-style-type: none"> - Check and, if required, replace the sensor and cable
F.1100	Immersion heater: Safety cut-out open	<p>The safety cut-out on the electric back-up heater is open due to:</p> <ul style="list-style-type: none"> - Insufficient volume flow or air in the building circuit - The immersion heater is operated when the building circuit is not filled - Immersion heater operation at flow temperatures above 98 °C trips the safety fuse of the safety cut-out and requires that the fuse be replaced - Feed-in of external heat into the building circuit 	<ul style="list-style-type: none"> - Check the circulation in the building circuit pump - If required, open the stopcocks - Replace the safety cut-out - Reduce or stop the external heat that is entering - Check that the dirt filter that is in place is permeable
F.1117	Compressor: Phase failure	<ul style="list-style-type: none"> - Defective fuse - Incorrect electrical connections - Mains voltage too low - Compressor/low tariff power supply not connected - Blocked by energy supply company for over three hours 	<ul style="list-style-type: none"> - Check the fuse - Checking the electrical connections - Check the voltage at the heat pump electrical connection - Reduce energy supply company anti-cycling time to under three hours
F.1120	Immersion heater: Phase failure	<ul style="list-style-type: none"> - Electric back-up heater defective - Poorly tightened electrical connections - Mains voltage too low 	<ul style="list-style-type: none"> - Check the electric back-up heater and its power supply - Check the electrical connections - Measure the voltage at the electrical connection for the electric back-up heater
F.9998	Connection fault: Heat pump	<ul style="list-style-type: none"> - eBUS cable not connected or connected incorrectly - Outdoor unit without supply voltage 	<ul style="list-style-type: none"> - Check the connection pipes between the power supply PCB and control PCB on the indoor and outdoor unit

K 5.4 kW back-up heater at 230 V

Internal control of the output levels at 230 V	Power consumption	Set value
0	0.0 kW	
1	0.7 kW	1 kW
2	1.2 kW	
3	1.8 kW	2 kW
4	2.2 kW	3 kW
5	3.2 kW	
6	3.8 kW	4 kW
7	4.7 kW	5 kW
8	5.4 kW	6 kW

L 8.54 kW back-up heater at 400 V

Internal control of the output levels at 400 V	Power consumption	Set value
0	0.0 kW	
1	0.7 kW	1 kW
2	1.2 kW	
3	1.8 kW	2 kW
4	2.3 kW	
5	3.0 kW	3 kW
6	3.9 kW	4 kW
7	4.7 kW	5 kW
8	5.6 kW	6 kW
9	6.2 kW	
10	7.0 kW	7 kW
11	7.9 kW	8 kW
12	8.5 kW	9 kW

M Inspection and maintenance work

#	Maintenance work	Interval	
1	Checking the pre-charge pressure of the expansion vessel	Annually	36
2	Checking the magnesium protection anode	Annually	36
3	Cleaning the domestic hot water cylinder	If required, at least every 2 years	
4	Check that the prioritising diverter valve can move easily (visually/audibly)	Annually	
5	Checking the electronics boxes, removing dust from the ventilation slits	Annually	

N Characteristic values for the internal temperature sensors, hydraulic circuit

Sensors: TT620 TT650

Temperature (°C)	Resistance (ohms)
0	33400
5	25902
10	20247
15	15950
20	12657
25	10115
30	8138
35	6589
40	5367
45	4398
50	3624
55	3002
60	2500
65	2092
70	1759
75	1486
80	1260
85	1074
90	918

Appendix

Temperature (°C)	Resistance (ohms)
95	788
100	680
105	588
110	510

O Characteristic values for the VR10 internal temperature sensors, cylinder temperature

Temperature (°C)	Resistance (ohms)
-40	88130
-35	64710
-30	47770
-25	35440
-20	26460
-15	19900
-10	15090
-5	11520
0	8870
5	6890
10	5390
15	4240
20	3375
25	2700
30	2172
35	1758
40	1432
45	1173
50	966
55	800
60	667
65	558
70	470
75	397
80	338
85	288
90	248
95	213
100	185
105	160
110	139
115	122
120	107
125	94
130	83
135	73
140	65
145	58
150	51

P Characteristic values for the VRC DCF outdoor temperature sensor

Temperature (°C)	Resistance (ohms)
-25	2167
-20	2067
-15	1976
-10	1862
-5	1745
0	1619
5	1494
10	1387
15	1246
20	1128
25	1020
30	920
35	831
40	740

Q Technical data



Note

The following performance data is only applicable to new products with clean heat exchangers.

Technical data – General

	VIH QW 190/6	VIH QW 190/6 E
Product dimensions, width	595 mm	595 mm
Product dimensions, height	1,880 mm	1,880 mm
Product dimensions, depth	693 mm	693 mm
Weight, without packaging	143 kg	146 kg
Weight, ready for operation	347 kg	351 kg
IP rating	IP 10B	IP 10B
Heating circuit connections	G 1"	G 1"
Heat source connections	G 1 1/4"	G 1 1/4"
Cold water and domestic hot water connections	G 3/4"	G 3/4"
Permissible height difference between outdoor unit and indoor unit	≤ 15 m	≤ 15 m

Technical data – Heating circuit

	VIH QW 190/6	VIH QW 190/6 E
Material in the heating circuit	Copper, copper-zinc alloy, stainless steel, ethylene propylene diene monomer rubber, brass, iron	Copper, copper-zinc alloy, stainless steel, ethylene propylene diene monomer rubber, brass, iron
Permissible water composition	Without frost or corrosion protection. Soften the heating water at water hardnesses from 3.0 mmol/l (16.8° dH) in accordance with Directive VDI2035 sheet 1	Without frost or corrosion protection. Soften the heating water at water hardnesses from 3.0 mmol/l (16.8° dH) in accordance with Directive VDI2035 sheet 1
Water content	16.0 l	16.0 l

Appendix

	VIH QW 190/6	VIH QW 190/6 E
Volume of the internal diaphragm expansion vessel	15 l	15 l
Minimum operating pressure	0.05 MPa (0.50 bar)	0.05 MPa (0.50 bar)
Maximum operating pressure	0.3 MPa (3.0 bar)	0.3 MPa (3.0 bar)
Max. heating mode flow temperature with compressor	75 °C	75 °C
Max. heating mode flow temperature with back-up heater		75 °C
Min. cooling mode flow temperature	7 °C	7 °C
Permissible medium in the decoupling circuit (separation heat exchanger accessory)	Propylene glycol/water mixture	Propylene glycol/water mixture
Sound power A7/W35 in accordance with EN 12102 / EN 14511 L _{WI} in heating mode	≤ 30 dB(A)	≤ 30 dB(A)
Sound power A7/W45 in accordance with EN 12102 / EN 14511 L _{WI} in heating mode	≤ 30 dB(A)	≤ 30 dB(A)
Sound power A7/W55 in accordance with EN 12102 / EN 14511 L _{WI} in heating mode	≤ 30 dB(A)	≤ 30 dB(A)
Sound power A7/W65 in accordance with EN 12102 / EN 14511 L _{WI} in heating mode	≤ 30 dB(A)	≤ 30 dB(A)
Sound power A35/W7 in accordance with EN 12102 / EN 14511 L _{WI} in cooling mode	≤ 30 dB(A)	≤ 30 dB(A)
Sound power A35/W18 in accordance with EN 12102 / EN 14511 L _{WI} in cooling mode	≤ 31 dB(A)	≤ 31 dB(A)

Technical data – Domestic hot water

	VIH QW 190/6	VIH QW 190/6 E
Water content of the domestic hot water cylinder	185 l	185 l
Heat exchanger nominal volume (heating coil)	8.6 l	8.6 l
Domestic hot water cylinder material	Steel, enamelled	Steel, enamelled
Insulation material for the domestic hot water cylinder	Neopor	Neopor
Min. insulating thickness	26 mm	26 mm
Max. insulating thickness	74 mm	74 mm
Corrosion protection	Magnesium anode	Magnesium anode
Maximum operating pressure	1.0 MPa (10.0 bar)	1.0 MPa (10.0 bar)
Max. cylinder temperature due to the heat pump	70 °C	70 °C
Max. cylinder temperature due to back-up heater		70 °C
Heat-up time in accordance with DIN EN 16147 to target cylinder temperature, A7 with an outdoor unit up to 5 kW	192 min	192 min
Power consumption during standby in accordance with DIN EN 16147, A7 – with an outdoor unit up to 5 kW	22 W	22 W

	VIH QW 190/6	VIH QW 190/6 E
Coefficient of performance (COP _{dhw}) in accordance with EN 16147, A7, L profile – with an outdoor unit up to 5 kW	2.57	2.57
Reference domestic hot water temperature in accordance with DIN EN 16147, A7 – with an outdoor unit up to 5 kW	49.9 °C	49.9 °C
Mixed water volume V40 in accordance with DIN EN 16147, A7 – with an outdoor unit up to 5 kW	230 l	230 l
Heat-up time in accordance with DIN EN 16147 to target cylinder temperature, A7 with an outdoor unit up to 7 kW	125 min	125 min
Power consumption during standby in accordance with DIN EN 16147, A7 – with an outdoor unit up to 7 kW	45 W	45 W
Coefficient of performance (COP _{dhw}) in accordance with EN 16147, A7, XL profile – with an outdoor unit up to 7 kW	2.55	2.55
Reference domestic hot water temperature in accordance with DIN EN 16147, A7 – with an outdoor unit up to 7 kW	51.6 °C	51.6 °C
Mixed water volume V40 in accordance with DIN EN 16147, A7 – with an outdoor unit up to 7 kW	246 l	246 l
Heat-up time in accordance with DIN EN 16147 to target cylinder temperature, A7 with an outdoor unit up to 12 kW	80 min	80 min
Power consumption during standby in accordance with DIN EN 16147, A7 – with an outdoor unit up to 12 kW	39 W	39 W
Coefficient of performance (COP _{dhw}) in accordance with EN 16147, A7, XL profile – with an outdoor unit up to 12 kW	2.61	2.61
Reference domestic hot water temperature in accordance with DIN EN 16147, A7 – with an outdoor unit up to 12 kW	52.1 °C	52.1 °C
Mixed water volume V40 in accordance with DIN EN 16147, A7 – with an outdoor unit up to 12 kW	258 l	258 l

Technical data – Electrics

	VIH QW 190/6	VIH QW 190/6 E
Rated voltage	230 V (+10%/-15%), 50 Hz, 1~/N/PE	230 V (+10%/-15%), 50 Hz, 1~/N/PE
Rated voltage		400 V (+10%/-15%), 50 Hz, 3~/N/PE
Rated power, maximum	0.06 kW	8.6 kW
Rated current, maximum, 230 V	2.6 A	23.5 A
Rated current, maximum, 400 V		13.6 A
Overvoltage category	II	II
Fuse type, characteristic C, slow-blow, three-pole switching (disconnection of the three mains connection lines in one switching operation)	Design in accordance with the selected connection diagrams	Design in accordance with the selected connection diagrams

Index

Index

A

Actuator test	35
Actuators, checking	35
Article number	17

B

Basic diagram	14
Building circuit, connecting	24

C

Cable duct, in the product	26
Calling up, code layer	32
Calling up, installer level	32
Calling up, statistics	32
Carrying straps	20, 23
CE marking	18
Check programmes	36
Checking, electrical installation	29
Checking, maintenance message	35
Checking, service message	35
Circulation pump, connecting	28
Code layer, calling up	32
Cold water connection	24
Comfort protection mode	35
Competent person	14
Component test	34
Condensate discharge, connecting	24

D

Data plate	17
Decommissioning	37
Displaying, Live Monitor	34
Displaying, status codes	34
Disposal, accessories	37
Disposal, packaging	37
Disposal, product	37
Domestic hot water connection	24

E

Electric back-up heater, enabling	32
Electric back-up heater, maximum output	32
Electrical installation, checking	29
Electricity	14
Energy supply company lockout	25

F

Factory settings, restoring	35
Fault codes	34
Fault memory	34
Fault symbol	36
Filling and purging	30
Filling pressure, displaying	32
Front casing, installing	22
Front casing, removing	21
Frost	15
Frost protection function	16
Function menu	34

H

Heating circuit, connecting	24
Hot water temperature	
Risk of scalding	15

I

Inspection work	36
Installation assistant	31
Installation clearances	19

Installer level, calling up	32
Intended use	14

L

Live Monitor, displaying	34
Low-water pressure protection	16

M

Maintenance message, checking	35
Maintenance work	36
Minimum clearances	19

O

Operating concept	29
-------------------------	----

P

Parameters, resetting	35
Power supply	26
Pre-charge pressure of expansion vessel	36
Product, separating	20
Product, separating into two modules	20
Product, switching on	31

Q

Qualification	14
---------------------	----

R

Regulations	15
Reset	34

S

Safety cut-out	16
Safety device	14
Screed drying, function	33
Self-test	34
Sensor test	35
Serial number	17
Service message, checking	35
Service partner	34
Spare parts	35
Statistics, calling up	32
Status codes, displaying	34
Switching on, product	31

T

Test menu	35
Tool	15
Transport	15
Treating the heating water	29

U

Unit configuration, checking	32
------------------------------------	----

V

Voltage	14
---------------	----

W

Wiring	28
--------------	----

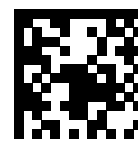

0020291511_01

0020291511_01 ■ 27.01.2020

Supplier

Vaillant Group International GmbH

Berghauser Strasse 40 ■ 42859 Remscheid

Tel. +492191 18 0

www.vaillant.info

© These instructions, or parts thereof, are protected by copyright and may be reproduced or distributed only with the manufacturer's written consent.