

Installation Guide

Spout- FWCU08

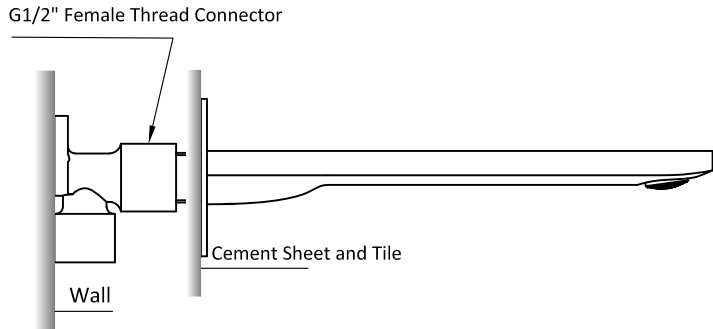
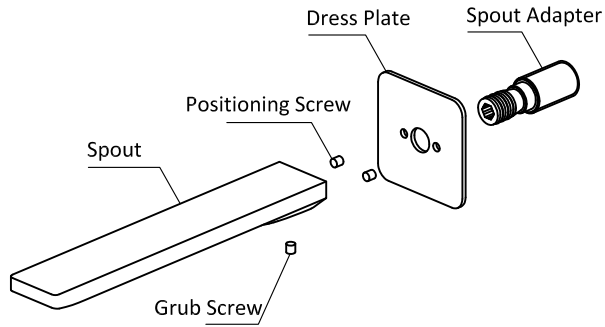

The inwall G1/2" female thread must be recessed or not exceed the cement sheet as shown.

1

Position the Angle Elbow and screw in place with screws provided. Connect inlet water supply to the G1/2" male connector.

Test and Check for Leaks.

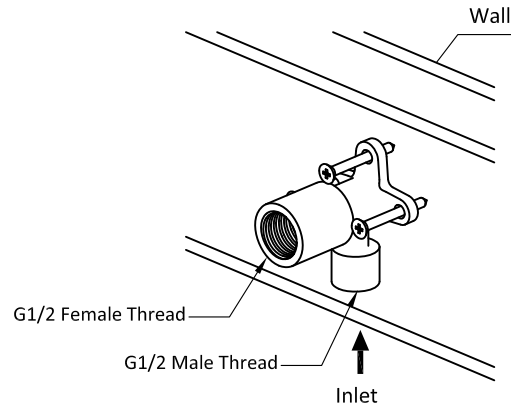

2

Drill a 30mm diameter hole through tiles and lining. Apply Teflon tape onto spout adapter, screw into the female thread connector.

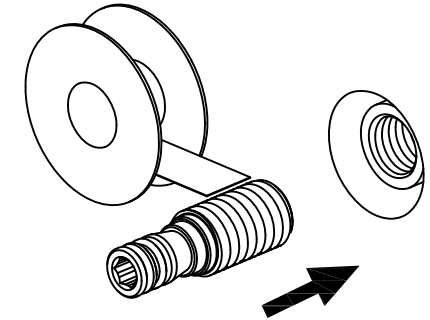

3

Fit the dress plate onto spout adapter. Tighten the positioning screw onto spout and then push the spout assy onto the spout adapter, ensure align the positioning hole and fasten grub screw.

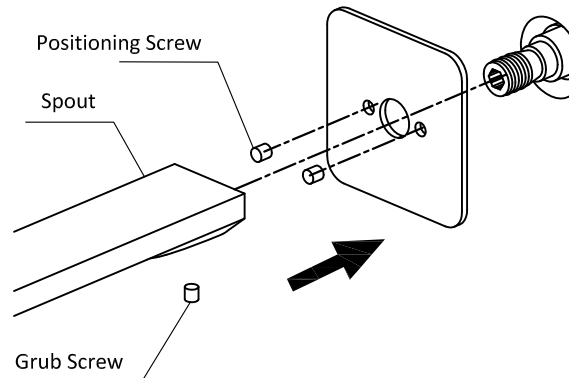

4

Finished work (Note: The spout must work together with a wall mixer)

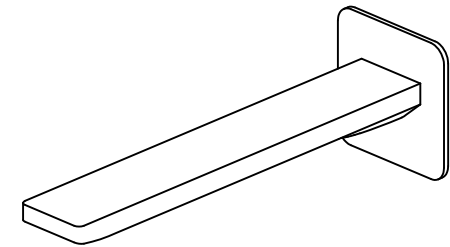

Notes

1. Pressure rating: 150-500kpa. If the pressure exceeds or is likely to exceed 550kpa, an approved pressure limiting device must be installed.
2. Temperature rating: 1-75°C. If the water temperature exceeds 55°C, an approved tempering valve must be fitted.
3. Flush out all pipes prior to installation.
4. Installation should comply with Australia standard AS/NZS3500 or relevant local authority requirements.

Maintenance and Care

1. All products should be cleaned with mild detergent or soapy water by using a soft cloth or dampened sponge.
2. Dry with a soft cloth after each use and clean regularly.
3. Do not use any chemical or abrasive cleaners.