

UF6716F1

Caleffi 6 x Circuit Composite Distribution Manifold



Technical Specification

- Type: Distribution
- Maximum percentage of glycol: 30%
- Maximum inlet temperature (°C): 60
- Maximum working pressure (Bar): 4
- Pipe to manifold connectors: 16x2mm
- Panel circuit outlet coupler: 1" F
- Pipe outlet centres (mm): 50
- Primary circuit centres (mm): 225

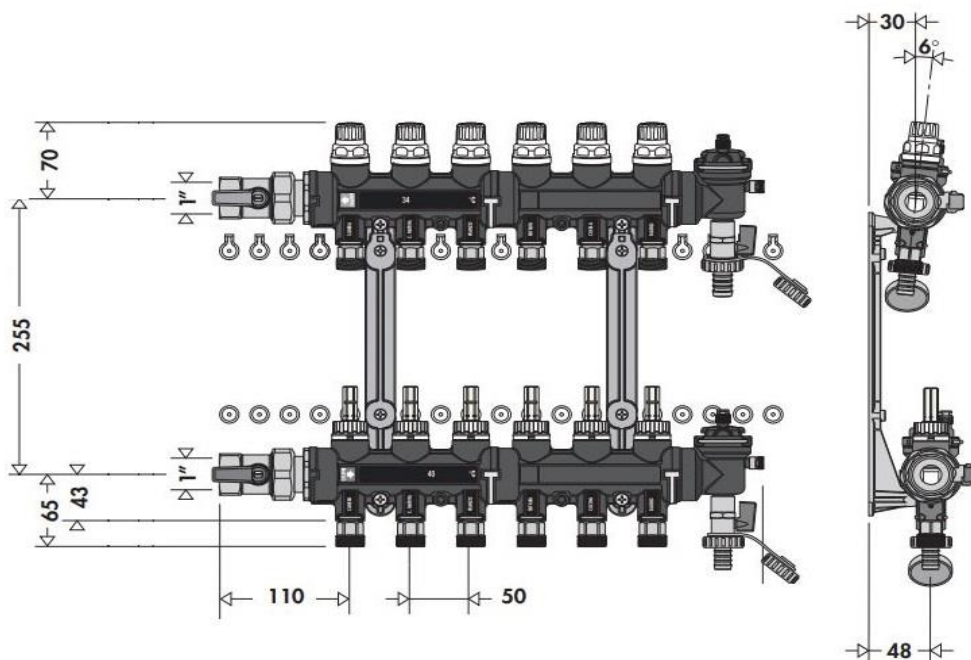

Warranty

[Download the latest warranty statement](#)

Features

The Caleffi composite underfloor panels are fully assembled, modules without cabinet ready to slot into the wall. The straight distribution panel version is suitable for low temperature heat sources feeding a low temperature underfloor network. The manifolds ensure that the flow to each circuit is regulated precisely and also control the shut-off, venting and manual removal of air from the system.

Manifolds come fully equipped with flow meters, balancing valves, automatic air vent, fill/drain cock, manifold shut off valves and liquid crystal temperature indicators all as standard.