

DBVO26

Grant Vortex Outdoor Diesel Condensing Boiler
26kW



Technical Specification

- Water content litre: 19
- Weight (dry) kg: 126.5
- Max. heat output kW: 26
- Flow & Return connections: 22mm
- Min. flow rate ($\Delta T=10^{\circ}\text{C}$) l/h: 2,200
- Condensate connection: 22mm
- Waterside resistance: 26 mbar
- Maximum static head: 28m
- Boiler thermostat range: 65°C to 75°C
- Limit (safety) stat shut off temp: 111°C
- Max. hearth temperature: 50°C
- Electricity supply: 240v - 50hz @ 5amp
- Motor power: 90 watts
- Starting current: 2.6 amps
- Running current: 0.85 amps
- Oil connection: 1/4" BSP
- Max operating press:

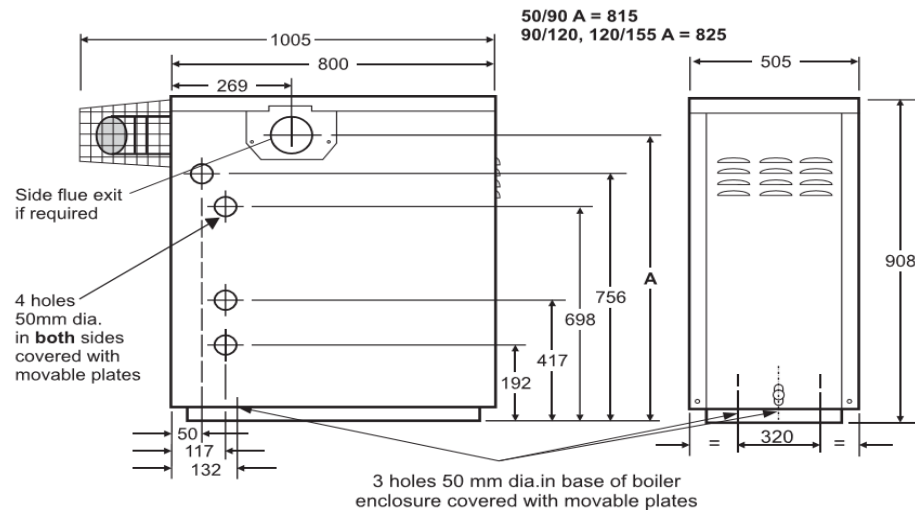

Warranty

[Download the latest warranty statement](#)

Features

- Floor standing outdoor 15.0 - 26kW diesel condensing boiler with dual set point for central heating and or an indirect domestic hot water system.
- High efficiency multipass combustion chamber with an internal Riello RDB blown diesel burner, automatic air vent valve, circulating pump, expansion tank and safety valve.
- 908mm high x 505mm wide x 800mm deep
- Made in Ireland