

## Installation and maintenance instructions



ecoTEC plus

VU, VUW ..6/5-5

**GB, IE**

**Publisher/manufacturer**

**Vaillant GmbH**

Berghauser Str. 40 ■ D-42859 Remscheid  
Tel. +49 21 91 18-0 ■ Fax +49 21 91 18-2810  
info@vaillant.de ■ www.vaillant.de



# Contents

## Contents

<b>1</b>	<b>Safety</b> .....	<b>4</b>	7.4	Restarting the installation assistants .....	19
1.1	Action-related warnings .....	4	7.5	Test programmes.....	19
1.2	Intended use .....	4	7.6	Performing a gas family check .....	20
1.3	General safety information .....	4	7.7	Using check programmes .....	20
1.4	Related documents.....	6	7.8	Checking and treating the heating water/filling and supplementary water .....	20
1.5	Related documents.....	7	7.9	Preventing low water pressure .....	21
<b>2</b>	<b>Notes on the documentation</b> .....	<b>8</b>	7.10	Flushing the heating installation for the first time ("cold") .....	21
2.1	Observing other applicable documents .....	8	7.11	Filling the heating installation .....	21
2.2	Storing documents.....	8	7.12	Purging the heating installation .....	22
2.3	Applicability of the instructions .....	8	7.13	Filling and purging the hot water system .....	22
2.4	Benchmark.....	8	7.14	Filling the condensate trap .....	23
<b>3</b>	<b>Product description</b> .....	<b>8</b>	7.15	Gas inspection.....	23
3.1	Product design.....	8	7.16	Checking leak-tightness .....	25
3.2	Information on the identification plate .....	9	7.17	Thoroughly flushing the heating installation ("hot").....	25
3.3	Serial number .....	9	<b>8</b>	<b>Adapting the unit to the heating installation.....</b>	<b>26</b>
3.4	CE label .....	9	8.1	Burner anti-cycling time .....	26
3.5	Energy Saving Trust Endorsed Products .....	10	8.2	Setting the maintenance interval .....	26
3.6	Hot Water Association .....	10	8.3	Setting the pump output.....	27
3.7	Compartment Ventilation .....	10	8.4	Setting the bypass valve.....	27
<b>4</b>	<b>Set-up</b> .....	<b>10</b>	8.5	Handing the product over to the operator.....	28
4.1	Unpacking the product.....	10	<b>9</b>	<b>Troubleshooting</b> .....	<b>28</b>
4.2	Checking the scope of delivery.....	10	9.1	Checking service messages.....	28
4.3	Transporting the product .....	10	9.2	Eliminating faults.....	28
4.4	Dimensions .....	11	9.3	Calling up and clearing the fault memory .....	28
4.5	Minimum clearances.....	11	9.4	Resetting parameters to factory settings .....	28
4.6	Using the installation template.....	12	9.5	Preparing the repair work .....	29
4.7	Wall-mounting the product.....	12	9.6	Replacing defective components.....	29
4.8	Removing the front casing.....	12	9.7	Completing repair work.....	33
4.9	Removing the side section .....	13	9.8	Checking the product for leak-tightness .....	33
<b>5</b>	<b>Installation</b> .....	<b>13</b>	<b>10</b>	<b>Inspection and maintenance</b> .....	<b>33</b>
5.1	Installation requirements .....	13	10.1	Function menu.....	33
5.2	Installing the gas connection .....	14	10.2	Electronics self-test.....	33
5.3	Checking the gas line for leak-tightness.....	14	10.3	Removing the compact thermal module .....	33
5.4	Installing the hot and cold water connection.....	14	10.4	Cleaning the heat exchanger.....	34
5.5	Connecting the domestic hot water cylinder .....	14	10.5	Checking the burner .....	34
5.6	Connecting the heating flow and heating return .....	14	10.6	Cleaning the condensate trap.....	35
5.7	Connecting the condensate drain pipework .....	15	10.7	Cleaning the filter in the cold water inlet.....	35
5.8	Installing the discharge pipe on the expansion relief valve.....	15	10.8	Installing the compact thermal module .....	35
5.9	Flue installation.....	15	10.9	Draining the product .....	35
5.10	Electrical installation .....	16	10.10	Checking the pre-charge pressure for the internal expansion vessel .....	35
<b>6</b>	<b>Operation</b> .....	<b>18</b>	10.11	Completing inspection and maintenance work ....	36
6.1	Operating concept .....	18	10.12	Checking the product for leak-tightness .....	36
6.2	Calling up the installer level.....	18	<b>11</b>	<b>Decommissioning</b> .....	<b>36</b>
6.3	Live Monitor (status codes) .....	18	11.1	Temporarily decommissioning the product.....	36
6.4	Setting the hot water temperature .....	18	11.2	Decommissioning the product .....	36
<b>7</b>	<b>Start-up</b> .....	<b>18</b>	<b>12</b>	<b>Recycling and disposal</b> .....	<b>36</b>
7.1	Carrying out the initial start-up.....	18	<b>13</b>	<b>Customer service</b> .....	<b>36</b>
7.2	Switching the product on and off .....	19	<b>Appendix</b> .....	<b>37</b>	
7.3	Running the installation assistants .....	19	<b>A</b>	<b>Installer level – Overview</b> .....	<b>37</b>

<b>B</b>	<b>Overview of diagnostics codes .....</b>	<b>39</b>
<b>C</b>	<b>Status codes – Overview .....</b>	<b>44</b>
<b>D</b>	<b>Overview of fault codes .....</b>	<b>45</b>
<b>E</b>	<b>Check programmes – Overview .....</b>	<b>48</b>
<b>F</b>	<b>Function menu – Overview .....</b>	<b>48</b>
<b>G</b>	<b>Wiring diagrams.....</b>	<b>49</b>
G.1	Wiring diagram, product for heating mode only, 12 - 35 kW.....	49
G.2	Connection diagram, product for heating mode only, ≥ 37 kW.....	51
G.3	Connection diagram, product with integrated hot water generation, 12 - 35 kW .....	53
G.4	Wiring diagram, product with integrated domestic hot water generation, ≥ 37 kW .....	55
<b>H</b>	<b>Inspection and maintenance work.....</b>	<b>56</b>
<b>I</b>	<b>Commissioning Checklist.....</b>	<b>57</b>
<b>J</b>	<b>Opening of the flue pipe.....</b>	<b>61</b>
J.1	Positioning of the opening of a fan-supported flue gas pipe .....	61
<b>K</b>	<b>Horizontal terminal positioning.....</b>	<b>62</b>
<b>L</b>	<b>Technical data.....</b>	<b>62</b>
<b>Index</b> .....		<b>70</b>

# 1 Safety

## 1 Safety

### 1.1 Action-related warnings

#### Classification of action-related warnings

The action-related warnings are classified in accordance with the severity of the possible danger using the following warning signs and signal words:

#### Warning symbols and signal words



#### **Danger!**

Imminent danger to life or risk of severe personal injury



#### **Danger!**

Risk of death from electric shock



#### **Warning.**

Risk of minor personal injury



#### **Caution.**

Risk of material or environmental damage

### 1.2 Intended use

There is a risk of injury or death to the user or others, or of damage to the product and other property in the event of improper use or use for which it is not intended.

The product is intended as a heat generator for closed heating installations and for hot water generation.

Depending on the gas-fired boiler type, the products referred to in these instructions must only be installed and operated in conjunction with the air/flue pipe accessories listed in the other applicable documents.

Intended use includes the following:

- observance of accompanying operating, installation and servicing instructions for the product and any other system components
- installing and fitting the product in accordance with the product and system approval
- compliance with all inspection and maintenance conditions listed in the instructions.

Intended use also covers installation in accordance with the IP code.

Any other use that is not specified in these instructions, or use beyond that specified in

this document shall be considered improper use. Any direct commercial or industrial use is also deemed to be improper.

#### **Caution.**

Improper use of any kind is prohibited.

### 1.3 General safety information

#### 1.3.1 Risk caused by inadequate qualifications

The following work must only be carried out by competent persons who are sufficiently qualified to do so:

- Set-up
  - Dismantling
  - Installation
  - Start-up
  - Inspection and maintenance
  - Repair
  - Decommissioning
- ▶ Observe all instructions that are included with the product.
  - ▶ Proceed in accordance with current technology.
  - ▶ Observe all applicable directives, standards, laws and other regulations.

#### 1.3.2 Risk of death from escaping gas

What to do if you smell gas in the building:

- ▶ Avoid rooms that smell of gas.
- ▶ If possible, open doors and windows fully and ensure adequate ventilation.
- ▶ Do not use naked flames (e.g. lighters, matches).
- ▶ Do not smoke.
- ▶ Do not use any electrical switches, mains plugs, doorbells, telephones or other communication systems in the building.
- ▶ If it is safe to do so, close the emergency control valve or the main isolator.
- ▶ If possible, close the gas isolator cock on the product.
- ▶ Warn other occupants in the building by yelling or banging on doors or walls.
- ▶ Leave the building immediately and ensure that others do not enter the building.
- ▶ Notify the gas supply company or the National Grid +44 (0) 800 111999 by tele-



phone once you are outside of the building.

### 1.3.3 Risk of death from leaks if the product is installed below ground level

Liquid gas accumulates at floor level. If the product is installed below ground level, liquid gas may accumulate at floor level if there are any leaks. In this case, there is a risk of explosion.

- ▶ Make sure that liquid gas cannot escape from the product or the gas line under any circumstance.

### 1.3.4 Risk of death due to blocked or leaking flue gas routes

Installation errors, damage, tampering, unauthorised installation sites or similar can cause flue gas to escape and result in a risk of poisoning.

What to do if you smell flue gas in the property:

- ▶ Open all accessible doors and windows fully to provide ventilation.
- ▶ Switch off the product.
- ▶ Check the flue gas routes in the product and the flue gas diversions.

### 1.3.5 Risk of poisoning and burns caused by escaping hot flue gases

- ▶ Only operate the product if the air/flue pipe has been completely installed.
- ▶ With the exception of short periods for testing purposes, only operate the product when the front casing is installed and closed.

### 1.3.6 Risk of death due to explosive and flammable materials

- ▶ Do not use the product in storage rooms that contain explosive or flammable substances (such as petrol, paper or paint).

### 1.3.7 Risk of death due to cabinet-type casing

Cabinet-type casing can give rise to dangerous situations when used on a product which is operated with an open flue.

- ▶ Ensure that the product is supplied with sufficient combustion air.

### 1.3.8 Risk of poisoning caused by insufficient combustion air supply

**Conditions:** Open-flued operation

- ▶ Ensure that the air supply to the product's installation room is permanently unobstructed and sufficient in accordance with the relevant ventilation requirements.

### 1.3.9 Risk of death due to lack of safety devices

The schematic drawings included in this document do not show all safety devices required for correct installation.

- ▶ Install the necessary safety devices in the system.
- ▶ Observe the applicable national and international laws, standards and guidelines.

### 1.3.10 Risk of death from electric shock

There is a risk of death from electric shock if you touch live components.

Before commencing work on the product:

- ▶ Disconnect the product from the power supply by switching off all power supplies at all poles (electrical partition with a contact gap of at least 3 mm, e.g. fuse or circuit breaker).
- ▶ Secure against being switched back on again.
- ▶ Check that there is no voltage.

### 1.3.11 Risk of being burned or scalded by hot components

- ▶ Only carry out work on these components once they have cooled down.

### 1.3.12 Risk of death from escaping flue gas

If you operate the product with an empty condensate trap / siphon, then flue gas may escape into the room air.

- ▶ In order to operate the product, ensure that the condensate trap / siphon is always full.



## 1 Safety



### 1.3.13 Risk of material damage caused by using an unsuitable tool

- ▶ Use the correct tool to tighten or loosen threaded connections.

### 1.3.14 Risk of material damage caused by frost

- ▶ Do not install the product in rooms prone to frost.

### 1.3.15 Risk of corrosion damage due to unsuitable combustion and room air

Sprays, solvents, chlorinated cleaning agents, paint, adhesives, ammonia compounds, dust or similar substances may lead to corrosion on the product and in the flue gas guiding.

- ▶ Ensure that the supply of combustion air is always free of fluorine, chlorine, sulphur, dust, etc.
- ▶ Ensure that no chemical substances are stored at the installation site.
- ▶ If you are installing the product in hairdressing salons, painter's or joiner's workshops, cleaning businesses or similar locations, choose a separate installation room in which the room air is technically free of chemical substances.

### 1.3.16 Risk of material damage caused by leak detection sprays and liquids

Leak detection sprays and liquids block the filter of the mass flow sensor on the Venturi, and thus destroy the mass flow sensor.

- ▶ During repair work, do not apply any leak detection sprays or liquids to the covering cap on the filter of the Venturi.

### 1.3.17 Risk of damage to the flexible gas pipe

The corrugated gas pipe may become damaged if weight is placed on it.

- ▶ Do not suspend the compact thermal module on the flexible gas pipe, for example during maintenance work.

## 1.4 Related documents

Installation and maintenance of the boiler must only be performed by a competent person with valid accreditation from the Health and Safety Executive in accordance with the "Gas Safety (Installation and Use) Regulations 1998" (hereinafter abbreviated to "competent person" or "heating specialist company"). The existing regulations, rules and guidelines must be observed when doing so. Any special requirements of Local Authorities, gas undertakings or insurers must be complied with. The competent person is also responsible for inspection, maintenance and repairs to the boiler, and for checking gas volume setting and flue gas analysis.

Installers shall carry out a full site risk assessment and put into place all necessary steps and procedures to comply with Health and safety at work act and ensure safety of themselves and others with regard to manual handling and working at height requirements.

During the appliance installation (and any subsequent work, such as, the replacement of major parts ) it will be necessary to employ caution. All installers and operatives involved from unloading the appliance until it is fully mounted on the wall in its final installed location must exercise full duty of care for themselves and others with regard to safety. When lifting and handling this appliance, operatives should employ assistance. In certain situations it may be necessary to use mechanical handling aids. Take care to avoid trip hazards, slippery or wet surfaces.

**Employers and installers should refer to the HSE web site for full advice and manual handling assessment charts (MAC) tool.**

In addition where no specific instructions are given then reference shall be made, but not restricted to, all applicable and relevant British Standards and codes of practice such as the following:

- Gas Safety (Installation and Use) regulations.
- All current Building Regulations for England, Northern Ireland and Wales, (as amended). This includes Approved Codes of Practice and approved documents and





- guidance for building regulations. (A to P and 7)
- The Building Standards, Scotland, and any requirements determined by the local authorities within.
- The Health and safety at work act
- COSHH Control of Substances Hazardous to Health.
- BS 7671 Requirements for electrical installations. IEE Wiring Regulations
- The Electricity at Work Regulations.
- The Water supply (water fittings) regulations 1999.
- Water bylaws 2000 (Scotland)
- BS 5854 Code of practice for flues and flue structures in buildings.
- BS EN 12828 Design of water-based heating systems.
- BS EN 806 Parts 1 - 5.
- BS 8558 Guide to the design, installation, testing and maintenance of services supplying water for domestic use within buildings and their curtilages.
- BS 6880 Code of practice for low temperature heating systems with outputs above 45 kW, Part 1, 2, and 3.
- BS 6891 Installation of low pressure gas pipe work of up to 35mm in domestic premises.
- BS 4814 Specification for: Expansion vessels using an internal diaphragm, for sealed hot water and heating systems.
- BS 7074 Application, selection and installation of expansion vessels and ancillary equipment for sealed water systems., Part 1 and 2.
- BS 7593 Code of practice for treatment of water in domestic hot water central heating systems.
- BS 12831 Heating systems in buildings. Method for calculating design heat load.
- BS EN 13831 Closed expansion vessels with built in diaphragm.
- EN 14336 Heating systems in buildings. Installation and commissioning of water based heating systems.
- BS 5440 – 1 Installation of flues and ventilation for gas appliances of rated input not exceeding 70kW\*

- BS 5440 – 2 Flueing and ventilation for gas appliances of rated input not exceeding 70kW\*
- \* 1st 2nd and 3rd family gases.
- BS 5449 Forced circulation hot water systems up to 45kW.
- BS EN 6798 Installation & maintenance of gas fired hot water boilers of rated input not exceeding 70kW net.
- BS 5482 - Part 1 Domestic butane and propane gas burning installations

Institute of Gas Engineers Publications:

- IGE/UP/1B (Edition 2) Tightness testing and direct purging of small natural gas installations.
- IGE/UP/ 7 (Edition 2) Gas in timber and light steel framed buildings.

Additionally for gas boilers systems with outputs greater than 70KW.

- BS 6644 Installation of gas boilers between 60 kW and 2 MW (2nd and 3rd family gases)
- BS 5449
- IGE/UP/1 (Edition 2) Strength testing, tightness testing and direct purging of industrial and commercial gas installations.
- IGE/UP/1A (Edition 2) Strength testing, tightness testing and direct purging of small, low pressure industrial and commercial natural gas installations.
- IGE/UP/10 Installation of gas appliances in industrial and commercial premises. Part 1 Flued appliances.
- The installation must comply with the current version of the Clean Air Act.

### 1.5 Related documents

- I.S. 813 Domestic Gas Installations
- I.S. 820 Non Domestic Gas Installations
- Building Control Act 2007
- ETCI Regulations for installing electrical systems





## 2 Notes on the documentation

### 2 Notes on the documentation

#### 2.1 Observing other applicable documents

- ▶ You must observe all the operating and installation instructions included with the system components.

#### 2.2 Storing documents

- ▶ Pass these instructions and all other applicable documents on to the system operator.

#### 2.3 Applicability of the instructions

These instructions apply only to:

##### Product article number

	Article number	Gas Council Number
VU 126/5-5 (H-GB) ecoTEC plus 612	0010021828	41-694-20
VU 156/5-5 (H-GB) ecoTEC plus 615	0010021829	41-694-21
VU 186/5-5 (H-GB) ecoTEC plus 618	0010021830	41-694-22
VU 186/5-5 (P-GB) ecoTEC plus 618	0010021831	41-694-23
VU 246/5-5 (H-GB) ecoTEC plus 624	0010021832	41-694-24
VU 306/5-5 (H-GB) ecoTEC plus 630	0010021833	41-694-25
VU 306/5-5 (P-GB) ecoTEC plus 630	0010021834	41-694-26
VU 386/5-5 (H-GB) ecoTEC plus 637	0010021835	41-694-27
VUW 196/5-5 (H-GB) ecoTEC plus 825	0010021823	47-044-83
VUW 246/5-5 (H-GB) ecoTEC plus 832	0010021824	47-044-84
VUW 246/5-5 (P-GB) ecoTEC plus 832	0010021825	47-044-85
VUW 286/5-5 (H-GB) ecoTEC plus 838	0010021826	47-044-86
VUW 306/5-5 (H-GB) ecoTEC plus 835	0010021822	47-044-82

#### 2.4 Benchmark

Vaillant is a licensed member of the Benchmark Scheme.

Benchmark places responsibilities on both manufacturers and installers. The purpose is to ensure that customers are provided with the correct equipment for their needs, that it is installed, commissioned and serviced in accordance with the manufacturer's instructions by a competent person approved at the time by the Health and Safety Executive and that it meets the requirements of the appropriate Building Regulations. The Benchmark Checklist can be used to demonstrate compliance with Building Regulations and should be provided to the customer for future reference.

Installers are required to carry out installation, commissioning and servicing work in accordance with the Benchmark Code of Practice which is available from the Heating and Hotwater Industry Council who manage and promote the Scheme.

Benchmark is managed and promoted by the Heating and Hotwater Industry Council.



For more information visit [www.centralheating.co.uk](http://www.centralheating.co.uk)

## 3 Product description

### 3.1 Product design

#### 3.1.1 Functional elements, product for heating mode only

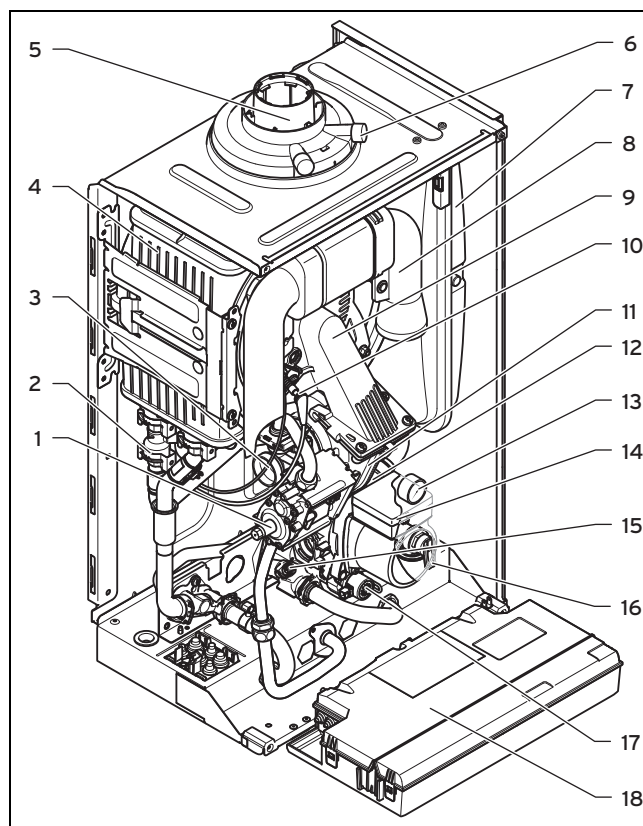

- |                                 |                           |
|---------------------------------|---------------------------|
| 1 Gas valve                     | 9 Compact thermal module  |
| 2 Water pressure sensor         | 10 Ignition electrode     |
| 3 Venturi with mass flow sensor | 11 Fan                    |
| 4 Heat exchanger                | 12 Automatic air vent     |
| 5 Connection for the flue pipe  | 13 Pressure gauge         |
| 6 Flue gas measuring stub pipe  | 14 Internal pump          |
| 7 Expansion vessel              | 15 Bypass valve           |
| 8 Air intake pipe               | 16 Expansion relief valve |
|                                 | 17 Diverter valve         |
|                                 | 18 Electronics box        |



### 3.1.2 Functional elements, product with hot water generation

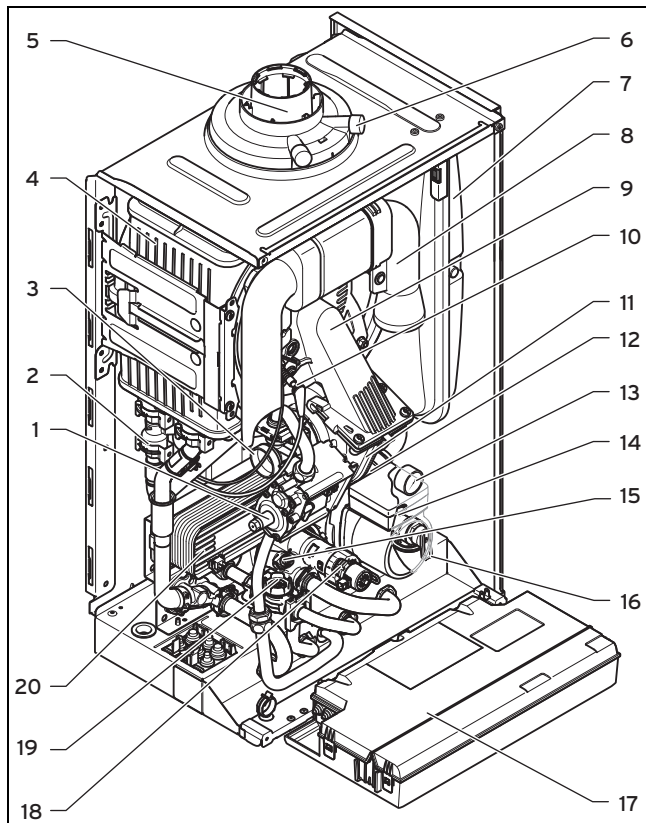

- |                                 |                                |
|---------------------------------|--------------------------------|
| 1 Gas valve                     | 11 Fan                         |
| 2 Water pressure sensor         | 12 Automatic air vent          |
| 3 Venturi with mass flow sensor | 13 Pressure gauge              |
| 4 Heat exchanger                | 14 Internal pump               |
| 5 Connection for the flue pipe  | 15 Bypass valve                |
| 6 Flue gas measuring stub pipe  | 16 Expansion relief valve      |
| 7 Expansion vessel              | 17 Electronics box             |
| 8 Air intake pipe               | 18 Diverter valve              |
| 9 Compact thermal module        | 19 Impeller sensor (hot water) |
| 10 Ignition electrode           | 20 Secondary heat exchanger    |

### 3.2 Information on the identification plate

The identification plate is mounted on the underside of the product in the factory.

Information on the identification plate	Meaning
	Read the instructions.
VU...	Vaillant gas-fired wall-hung boiler for heating
VUW..., VUI...	Vaillant gas-fired wall-hung boiler for heating and hot water generation
..6/5-5	Calorific value power/product generation equipment
ecoTEC plus	Product designation
2H, G20 – 20 mbar (2.0 kPa)	Gas group and gas connection pressure as set at the factory

Information on the identification plate	Meaning
ww/yyyy	Date of manufacture: Week/year
Cat.	Approved gas boiler category
Types	Approved units of type
PMS	Permissible total overpressure in heating mode
PMW	Permissible total overpressure during hot water generation
T <sub>max.</sub>	Max. flow temperature
ED 92/42	Current efficiency directive fulfilled with 4* rating
V Hz	Mains voltage and mains frequency
W	Max. electrical power consumption
IP	Level of protection
	Heating mode
	Hot water generation
P	Nominal heat output range
Q	Heat input range
D	Nominal hot water draw-off rate
	Bar code with serial number, 7th to 16th digit = product article number

**Note**  
Make absolutely sure that the product is compatible with the gas group at the installation site.

### 3.3 Serial number

The serial number can be found on a plastic label behind the front flap and on the identification plate.

**Note**  
The serial number can also be shown on the display of the product (→ Operating instructions).

### 3.4 CE label



The CE label shows that the products comply with the basic requirements of the applicable directives as stated on the identification plate.

The declaration of conformity can be viewed at the manufacturer's site.

## 4 Set-up

### 3.5 Energy Saving Trust Endorsed Products



Only the most energy efficient products can carry the 'Energy Saving Trust Endorsed Product' brandmark making it easy for consumers to choose products that have met strict energy performance criteria.

Available for: Boilers, Heating controls and chemical inhibitors, the Energy Saving Trust endorsed product brandmark gives consumers confidence that a product will cost less to run, help lower energy bills and reduce carbon emissions.

#### About the Energy Saving Trust

Energy Saving Trust is an independent and impartial organisation that provides trusted energy saving advice to empower millions of people to lead affordable, low energy lifestyles. For more information visit [energysavingtrust.org.uk](http://energysavingtrust.org.uk)

### 3.6 Hot Water Association

Vaillant is a full member of the Hot Water Association and promotes the scheme in association with its cylinder range. Details are available on the web site [www.vaillant.co.uk](http://www.vaillant.co.uk)



### 3.7 Compartment Ventilation

The boilers are very high efficiency appliances.

As a consequence the heat loss from the appliance casing during operation is very low.

Compartment ventilation is not required as the products are only certified, and can only be fitted with a concentric flue system.

## 4 Set-up

### 4.1 Unpacking the product

1. Remove the product from its box.
2. Remove the protective film from all parts of the product.

### 4.2 Checking the scope of delivery

- ▶ Check that the scope of delivery is complete and intact.

#### 4.2.1 Scope of delivery

**Applicability:** Product with heating mode only

Number	Description
1	Heat generator
1	Installation kit containing the following:
1	- Product retainer
1	- Expansion relief valve connector

Number	Description
1	- Gas connection pipe
2	- Heating flow/return connection pipe
3	- Service valve
3	- Bag with small parts
1	Lower cover
1	Installation template
1	Condensate drain hose
1	Enclosed documentation

#### 4.2.2 Scope of delivery

**Applicability:** Product with integrated hot water generation

Number	Description
1	Heat generator
1	Installation kit containing the following:
1	- Product retainer
1	- Expansion relief valve connector
1	- Gas connection pipe
2	- Heating flow/return connection pipe
2	- Cold water, hot water connection pipe
4	- Service valve
3	- Bag with small parts
1	Lower cover
1	Installation template
1	Condensate drain hose
1	Enclosed documentation

### 4.3 Transporting the product

#### 4.3.1 General

- ▶ Hold the load as close as possible to your body. Do not twist your body – instead, reposition your feet.
- ▶ If the unit is being lifted by two persons, ensure your movements are coordinated during lifting.
- ▶ Avoid bending your upper body – do not lean forwards or to the side.
- ▶ Wear appropriate cut-resistant and non-slip gloves to protect yourself against sharp edges and maintain a safe and secure grip.
- ▶ If required, get somebody to assist you in this.

#### 4.3.2 Unloading the box from the delivery van

- ▶ It is recommended that two people lift the unit together.
- ▶ Lift the box using the straps provided.
- ▶ Use safe lifting techniques – keep your back straight and bend your legs at the knee.
- ▶ Hold the load as close as possible to your body.
- ▶ If the unit is being lifted by two persons, ensure your movements are coordinated during lifting.
- ▶ If required, get somebody to assist you in this.

### 4.3.3 Transporting the box from the delivery point to the installation site – ground floor

- ▶ It is recommended that two people lift the unit together.
- ▶ Use safe lifting techniques – keep your back straight and bend your legs at the knee.

### 4.4 Dimensions

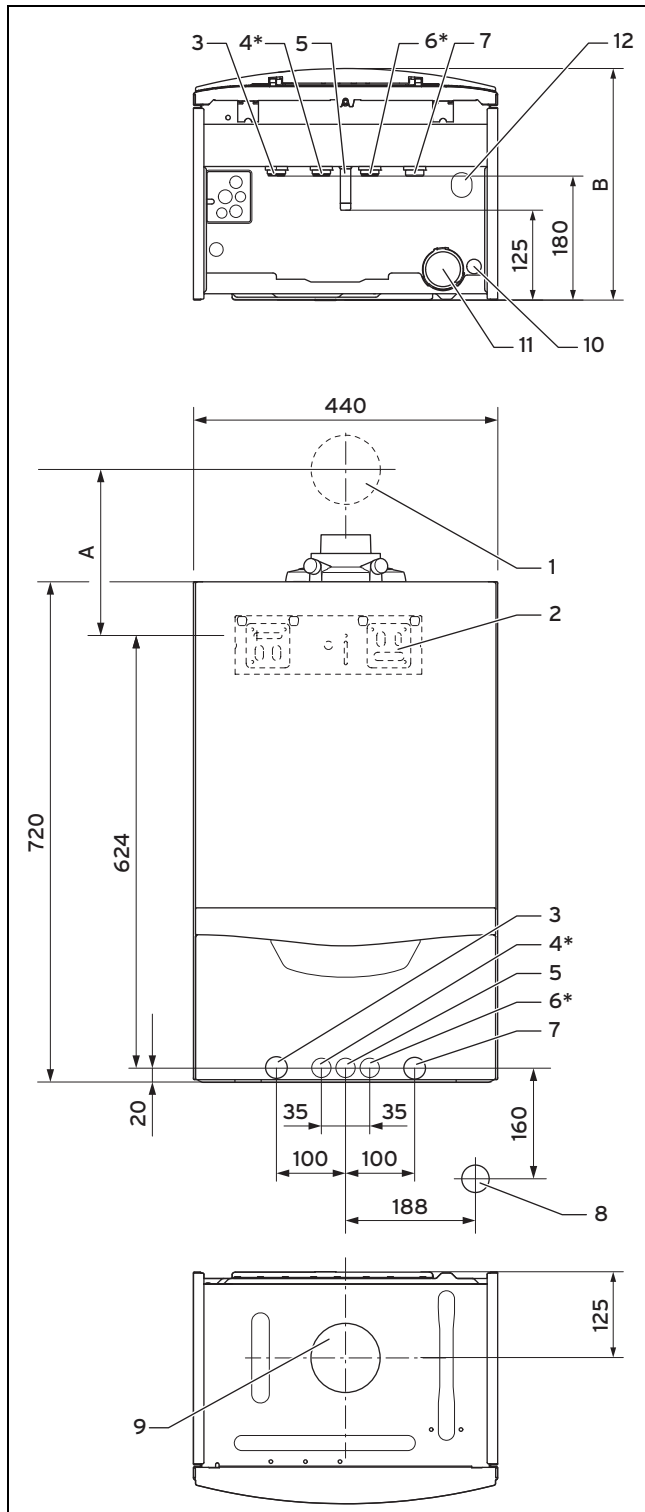

- |   |                                  |   |   |
|---|----------------------------------|---|---|
| 1 | Flue pipe wall duct              | 4 | Hot water connection (15 × 1.5 diameter)  |
| 2 | Product holder                   | 5 | Gas connection (15 × 1.5 diameter)        |
| 3 | Heating flow (22 × 1.5 diameter) | 6 | Cold water connection (15 × 1.5 diameter) |

- |    |   |    |  |
|----|---|----|--|
| 7  | Heating return (22 × 1.5 diameter)              | 12 | Drain line/heating expansion relief valve connection, 15 mm diameter |
| 8  | R1 tundish/condensate trap connection           | *  | Only products with integrated hot water generation                   |
| 9  | Flue pipe connection                            | ** | Only products with heating mode only                                 |
| 10 | Condensate discharge connection, 19 mm diameter |    |  |
| 11 | Condensate trap                                 |    |  |

Consult the installation template that is supplied to find the dimension A.

### Installation depth, dimension B

VU 126/5-5 (H-GB) ecoTEC plus 612	338 mm
VU 156/5-5 (H-GB) ecoTEC plus 615	338 mm
VU 186/5-5 (H-GB) ecoTEC plus 618	338 mm
VU 186/5-5 (P-GB) ecoTEC plus 618	338 mm
VU 246/5-5 (H-GB) ecoTEC plus 624	338 mm
VU 306/5-5 (H-GB) ecoTEC plus 630	372 mm
VU 306/5-5 (P-GB) ecoTEC plus 630	372 mm
VU 386/5-5 (H-GB) ecoTEC plus 637	406 mm
VUW 196/5-5 (H-GB) ecoTEC plus 825	338 mm
VUW 246/5-5 (H-GB) ecoTEC plus 832	338 mm
VUW 246/5-5 (P-GB) ecoTEC plus 832	338 mm
VUW 306/5-5 (H-GB) ecoTEC plus 835	372 mm
VUW 286/5-5 (H-GB) ecoTEC plus 838	406 mm

### 4.5 Minimum clearances

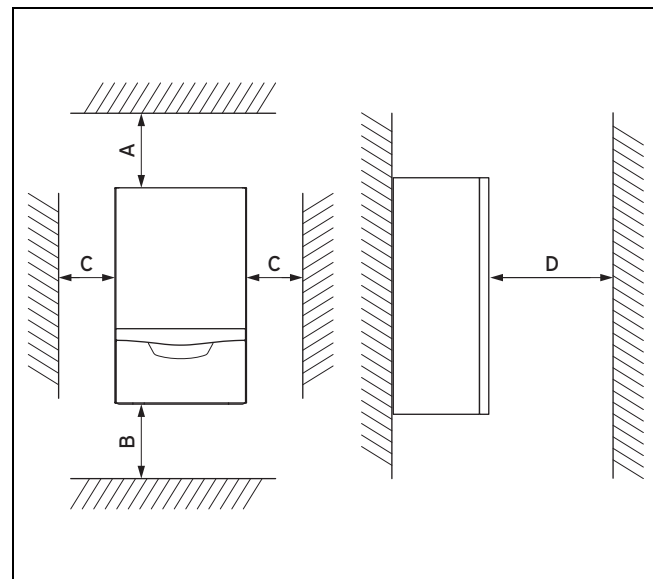

	Minimum clearance
A	165 mm: Air/flue pipe, 60/100 mm diameter 275 mm: Air/flue pipe, 80/125 mm diameter
B	180 mm; optimum approx. 250 mm
C	5 mm; optimum approx. 50 mm
D	500 mm in front of the heat generator to enable easy access for maintenance work (may be provided by an opening door).

## 4 Set-up

It is not necessary to maintain a clearance between the product and components made of combustible materials that go beyond the minimum clearances.

### 4.6 Using the installation template

- ▶ Use the installation template to ascertain the locations at which you need to drill holes and make breakthroughs.

### 4.7 Wall-mounting the product

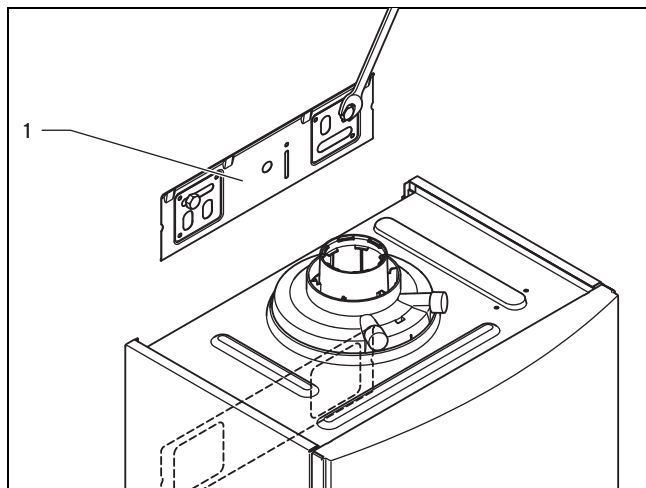

1. Check whether the wall has sufficient load-bearing capacity to bear the operational weight of the product.
2. Check if the supplied fixing material may be used for the wall.

**Conditions:** The load-bearing capacity of the wall is sufficient, The fixing material may be used for the wall

- ▶ Wall-mount the product as described.
- ▶ Install the product bracket **(1)** on the wall.
- ▶ Hang the product on the product bracket from above using the suspension bracket.

**Conditions:** The load-bearing capacity of the wall is not sufficient

- ▶ Ensure that wall-mounting apparatus on-site has a sufficient load-bearing capacity. Use individual stands or primary walling, for example.
- ▶ Do not wall-mount the product if you cannot provide wall-mounting apparatus with a sufficient load-bearing capacity.

**Conditions:** The fixing material may not be used for the wall

- ▶ Wall-mount the product as described using the permitted fixing material provided on-site.

### 4.8 Removing the front casing

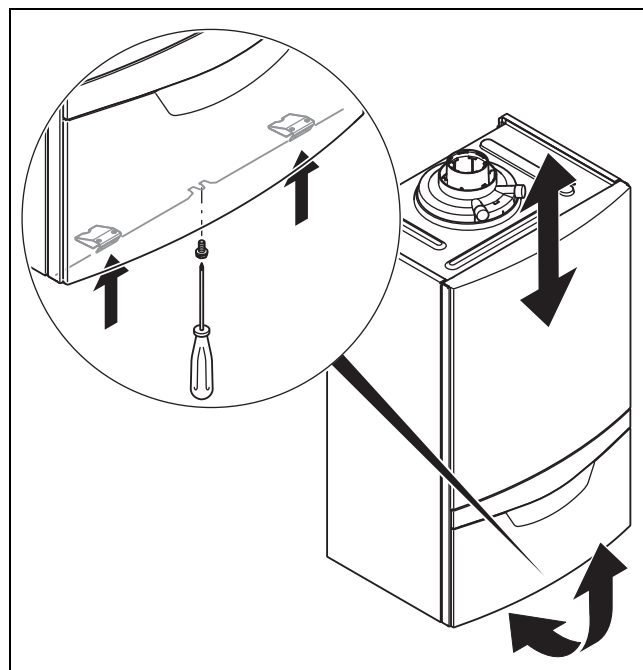

- ▶ Remove the front casing as shown in the illustration.

4.9 Removing the side section

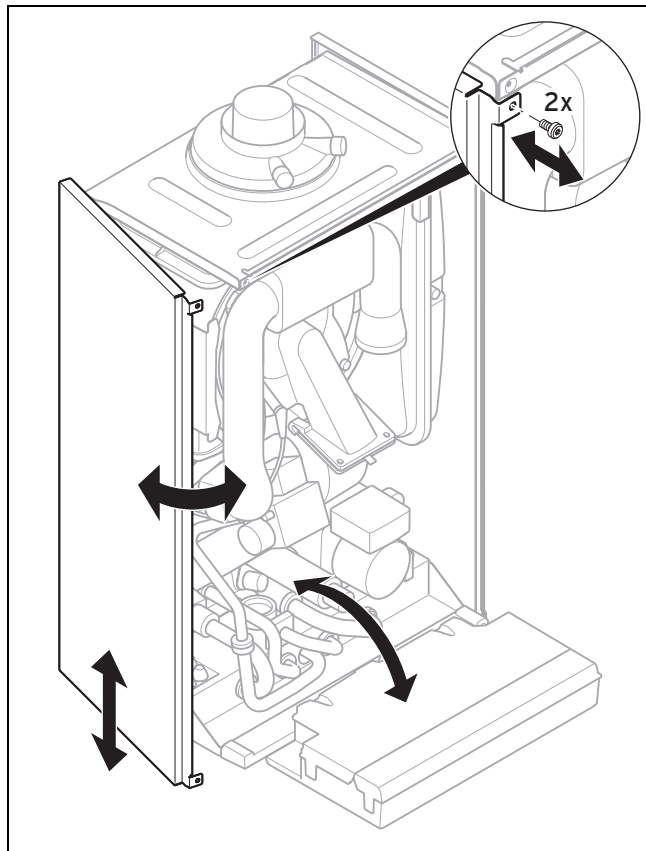

- ▶ If, during gas leak-tightness tests, you also place the gas lines and the gas valve in the product under pressure, use a max. test pressure of 11 kPa (110 mbar).
- ▶ If you cannot limit the test pressure to 11 kPa (110 mbar), close any gas isolator cocks that are installed upstream from the product before you carry out the gas leak-tightness test.
- ▶ If, during gas leak-tightness tests, you have closed the gas isolator cock that is installed upstream of the product, relieve the gas line pressure before you open this gas isolator cock.



**Caution.**  
**Risk of material damage caused by mechanical deformation.**

Removing both side sections may cause mechanical distortion in the product, which may cause damage to the piping, for example, and potentially result in leaks.

- ▶ Always only remove one side section – never both side sections at the same time.

- ▶ Remove the side section as shown in the illustration.

5 Installation



**Danger!**  
**Risk of scalding and/or risk of material damage due to incorrect installation leading to escaping water.**

Stresses in supply lines can cause leaks.

- ▶ Install the supply lines without tension.



**Caution.**  
**Risk of material damage due to the gas leak-tightness test.**

At a test pressure of >11 kPa (110 mbar), gas leak-tightness tests may cause damage to the gas valve.



**Caution.**  
**Risk of material damage caused by corrosion**

Due to non-diffusion-tight plastic pipes in the heating installation, air gets into the heating water. Air in the heating water causes corrosion in the heat generator circuit and in the product.

- ▶ If you use non-diffusion-tight plastic pipes in the heating installation, ensure that no air gets into the heat generator circuit.



**Caution.**  
**Risk of material damage due to heat transfer during soldering.**

- ▶ Only solder connectors if the connectors are not yet screwed to the service valves.



**Caution.**  
**Risk of material damage caused by changes to the pipes that have already been connected.**

- ▶ Only bend connection pipes if they have not yet been connected to the product.

5.1 Installation requirements

5.1.1 Information on liquefied petroleum gas operation

In the as-delivered condition, the product is preset for operation with the gas group indicated on the data plate.

5.1.2 Purging the liquid gas tank

If the liquid gas tank is not purged properly, this may result in ignition problems.

- ▶ Ensure that the liquid gas tank has been purged properly before installing the product.
- ▶ If required, contact the filler or the liquid gas supplier.

## 5 Installation

### 5.1.3 Using the correct type of gas

Using the incorrect type of gas may cause fault shutdowns in the product. Ignition and combustion noise may occur in the product.

- ▶ Only use the gas type listed on the data plate.

### 5.1.4 Required preliminary work

1. Install a stop cock in the gas line.
2. Make sure that the existing gas meter is capable of passing the rate of gas supply required.
3. Check that the volumetric capacity of the expansion vessel is sufficient for the system volume.

**Conditions:** The volume of the installed expansion vessel is insufficient

- ▶ Install an additional expansion vessel, connected as close to the product as possible, in the heating return.

**Conditions:** External expansion vessel installed and warm start active

- ▶ Install a non-return valve in the product outlet (heating flow) or decommission the internal expansion vessel in order to prevent the warm start function from being increasingly activated due to backflow.
4. Install a tundish with siphon for the condensate discharge and the exhaust pipe on the expansion relief valve. Lay as short a drain line as possible, at a downward gradient away from the tundish.
  5. Insulate bare pipes exposed to environmental influences to protect them from frost using suitable insulating material.

### 5.2 Installing the gas connection

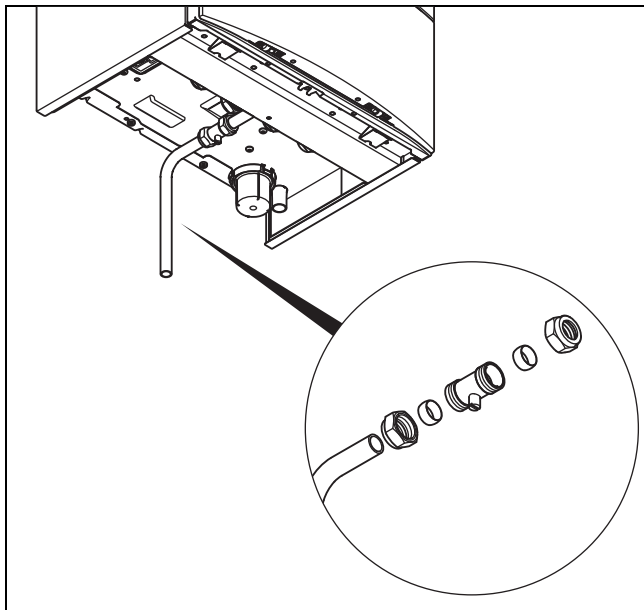

1. Install the gas pipe in accordance with the recognised rules of technology.
2. Connect the product to the gas line as shown in accordance with the recognised rules of good engineering practice.
3. Remove the residues from the gas line by blowing through the gas line beforehand.
4. Purge the gas line before start-up.

### 5.3 Checking the gas line for leak-tightness

- ▶ Check the entire gas line properly for leak-tightness.

### 5.4 Installing the hot and cold water connection

**Applicability:** Product with integrated hot water generation

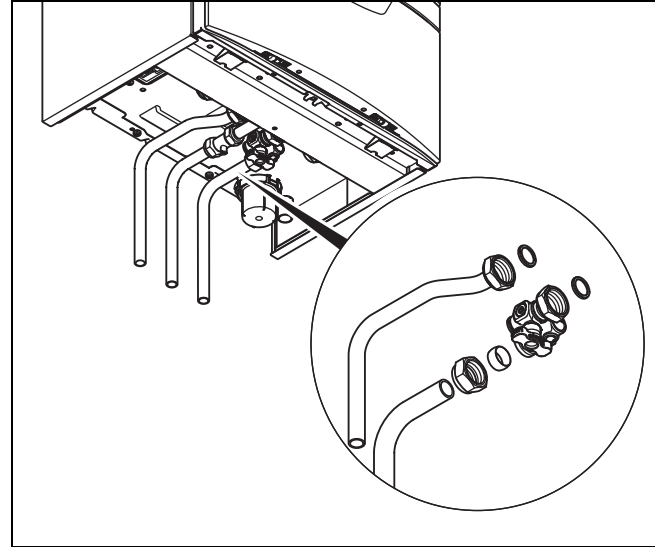

1. Make the water connections as shown in accordance with the relevant standards.
2. Ensure correct water pressure and flow requirements and that any expansion can be accommodated with the cold supply pipe work.

### 5.5 Connecting the domestic hot water cylinder

**Applicability:** Product with heating mode only

- ▶ When connecting the domestic hot water cylinder, follow the Installation instructions for the domestic hot water cylinder.

### 5.6 Connecting the heating flow and heating return

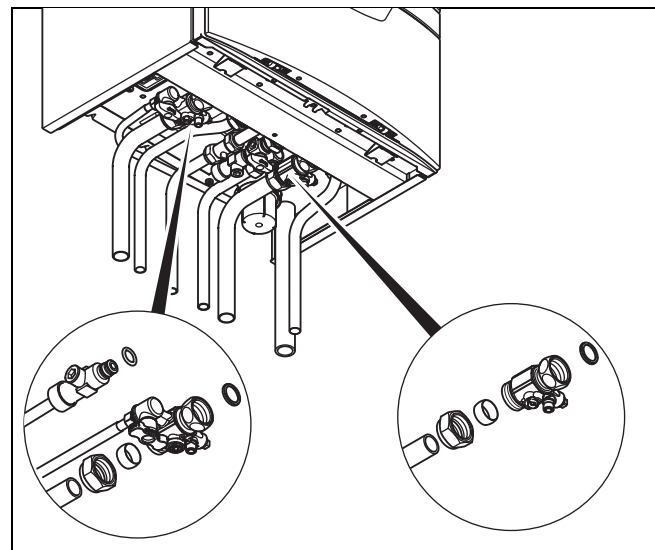

- ▶ Make the heating connections as shown in accordance with the relevant standards.



**5.7 Connecting the condensate drain pipework**



**Danger!**  
**Risk of death from escaping flue gases!**

The condensate drain pipework for the siphon must not be connected tightly to waste-water piping because, otherwise, the internal condensate trap may be drained fully and flue gas may escape.

- ▶ Do not connect the condensate drain pipework tightly to the waste-water piping.

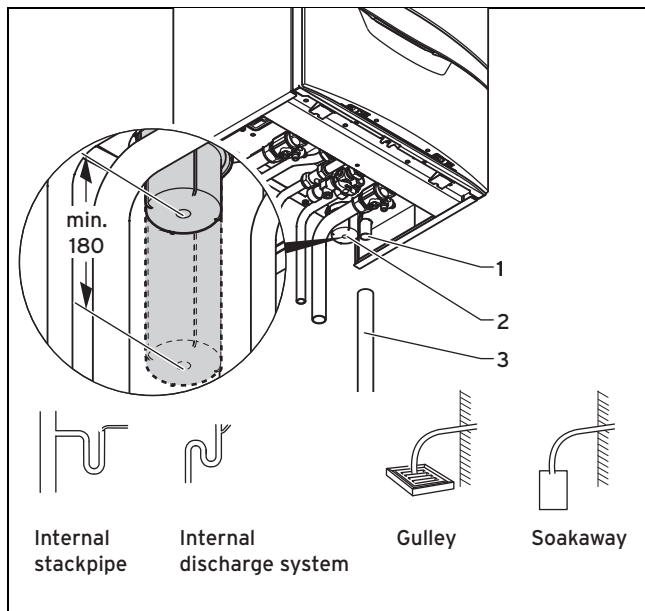

The product is equipped with a condensate trap (2). (The filling height is 145 mm). The condensate trap collects the condensate that has formed in a vessel with a capacity of approximately 200 ml, and intermittently releases the contents into the discharge pipe. This minimises the risk of the discharge pipe freezing.

- ▶ Connect the condensate discharge (1) to condensate drain pipework (3) which has a minimum internal diameter of 19 mm (22 mm outside diameter for all external pipes) and is made from an acid-resistant material (e.g. plastic overflow pipe).
  - The condensate discharge pipework must have a continuous fall (45 mm per metre) and should whenever possible terminate at a suitable discharge point within the heated envelope of the building that will remain frost free under long periods of low external temperatures.
- ▶ During installation remove all burrs from inside of cut pipe work and avoid excessive adhesive which may trap small pockets of water close to the pipe wall which can freeze and build into a larger ice plug.
- ▶ As with other pipe work insulate the condensate discharge pipe to minimise any risk of freezing and beware when crossing cavities that the fall is maintained and the pipe sleeved.
- ▶ Ensure that the condensate drain pipework terminates in a suitable location. Further information can be obtained from BS 6798 Specification for installation of gas-fired boilers of rated input not exceeding 70 kW net.

- ▶ Leave an installation space of at least 180 mm beneath the condensate trap.

**5.8 Installing the discharge pipe on the expansion relief valve**

1. Install the discharge pipe for the expansion relief valve so that it does not interfere with the removal and fitting of the lower section of the condensate trap.

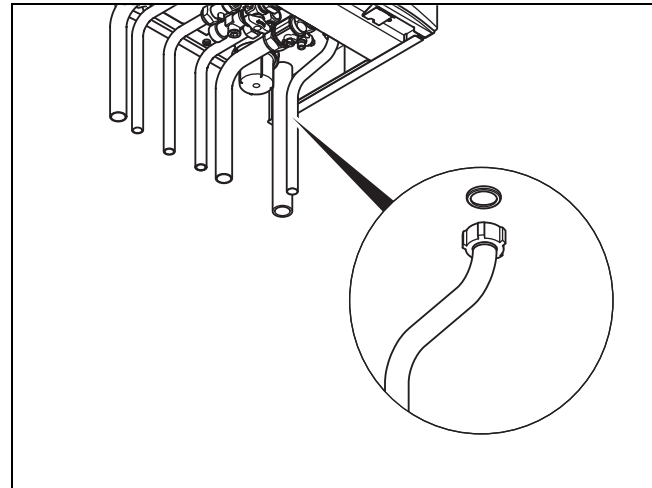

2. Install the discharge pipe as shown (do not shorten).
3. Make sure that the end of the pipe is visible.
4. Ensure that discharged water or steam cannot cause injury to persons or damage to electronic components.
5. Ensure the discharge pipe work is installed, routed and terminated correctly to minimise the risk of freezing up.

**5.9 Flue installation**

**5.9.1 Installing and connecting the flue pipe**

1. You can find out which flue pipes may be used by consulting the enclosed flue pipe installation manual.
2. Observe the information on positioning the opening for the flue pipe. This information can be found in the appendix.

**Conditions:** Installation in damp rooms

- ▶ You must connect the product to a room-sealed air/flue gas installation. The combustion air must not be taken from the installation site.



**Caution.**  
**Risk of poisoning due to escaping flue gas.**

Mineral-oil-based greases can damage the seals.

- ▶ Instead of grease, use only water or commercially available soft soap to aid installation.

3. Install the flue pipe using the installation manual.

## 5 Installation

### 5.9.2 Replacing the connection piece for the air/flue pipe as required

1. Replace the connection piece for the air/flue pipe as required. The product-specific standard equipment is listed under Technical data.
2. Remove the connection piece for the air/flue pipe. (→ Page 16)
3. **Alternatives 1 / 2**
  - ▶ If required, install the connection piece for the air/flue pipe, 80/125 mm diameter. (→ Page 16)
3. **Alternatives 2 / 2**
  - ▶ If required, install the connection piece with offset for the air/flue pipe, 60/100 mm diameter. (→ Page 16)

#### 5.9.2.1 Removing the connection piece for the air/flue pipe

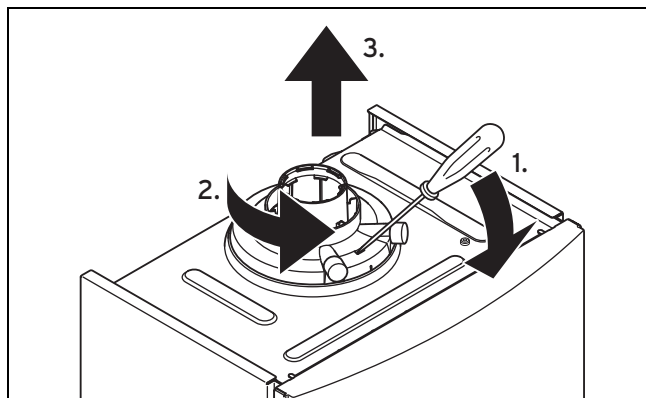

1. Insert a screwdriver into the slot between the measuring stub pipes.
2. Press the screwdriver carefully down (1.).
3. Turn the connection piece anticlockwise (2.) as far as it will go and then remove it by pulling it upwards (3.).

#### 5.9.2.2 Installing the connection piece for the air/flue pipe, 80/125 mm diameter

1. Remove the connection piece for the air/flue pipe. (→ Page 16)
2. Insert the alternative connection piece. In doing so, pay attention to the latching lugs.
3. Turn the connection piece clockwise until it clicks into position.

#### 5.9.2.3 Installing the connection piece with offset for the air/flue pipe, 60/100 mm diameter

1. Remove the connection piece for the air/flue pipe. (→ Page 16)

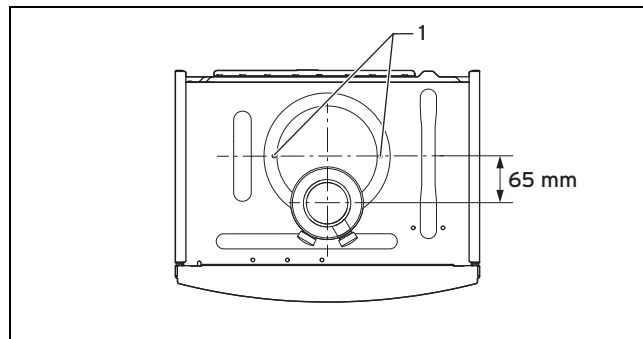

2. Insert the alternative connection piece with offset towards the front.
3. Use two screws (1) to secure the connection piece to the product.

### 5.10 Electrical installation

Only qualified electricians may carry out the electrical installation.



#### **Danger!**

#### **Risk of death from electric shock!**

Mains connection terminals L and N remain live even if the on/off switch is turned off:

- ▶ Switch off the power supply.
- ▶ Secure the power supply against being switched on again.

#### 5.10.1 Opening the electronics box

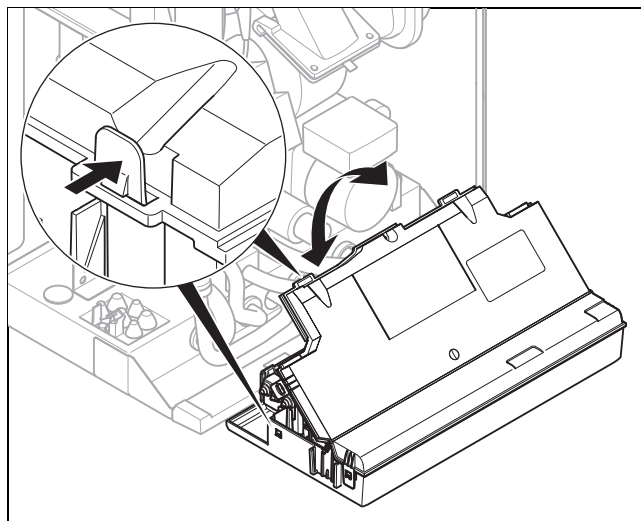

- ▶ Open the electronics box as shown in the illustration.

#### 5.10.2 Carrying out the wiring



#### **Caution.**

#### **Risk of material damage caused by incorrect installation.**

Mains voltage at incorrect terminals and plug terminals may destroy the electronics.

- ▶ Do not connect any mains voltage to the eBUS terminals (+/-).

- ▶ Only connect the mains connection cable to the terminals marked for the purpose.

1. Route the connection cables of the components to be connected through the cable duct provided on the underside of the product on the left.
2. Use strain reliefs.
3. Shorten the connection cables as necessary.

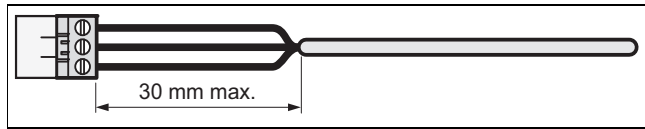

4. To prevent short circuits if a strand accidentally comes loose, only strip the outer sheathing of flexible lines to a maximum of 30 mm.
5. Ensure the inner conductor insulation is not damaged when stripping the outer sheathing.
6. Only strip inner conductors just enough to establish good, sound connections.
7. To avoid short circuits resulting from loose individual wires, fit conductor end sleeves on the stripped ends of the conductors.
8. Screw the respective plug to the connection cable.
9. Check whether all conductors are sitting mechanically securely in the terminals of the plug. Remedy this if necessary.
10. Plug the plug into the associated PCB slot; see the connection diagram in the appendix.

### 5.10.3 Establishing the power supply



#### Caution.

#### Risk of material damage due to high connected voltage.

At mains voltages greater than 253 V, electronic components may be damaged.

- ▶ Make sure that the rated voltage of the mains is 230 V.

1. Make sure that the nominal mains voltage is 230 V.
2. Provide one common electricity supply for the boiler and for the corresponding controller:
  - Power supply: Single-phase, 230 V, 50 Hz
  - Fuse protection: ≤ 3 A
3. Open the electronics box. (→ Page 16)
4. Connect the product using a fixed connection and an electrical partition with a contact opening of at least 3 mm (e.g. fuses or power switches).
5. Route a three-core mains connection cable that complies with the relevant standards through the cable duct and into the product.
  - Mains connection line: Flexible line
6. Carry out the wiring. (→ Page 16)
7. Remove the supplied plug from the bracket in the electronics box and screw the plug onto the mains connection cable.
8. Close the electronics box.
9. Make sure that access to the mains connection is always available and is not covered or blocked.

### 5.10.4 Installing the product in a moist environment



#### Danger!

#### Risk of death from electric shock!

If you install the product in a room with high levels of moisture, e.g. a bathroom, observe the nationally recognised technical standards for electrical installations. If you use the factory-installed connection cable, if installed, with an earthed plug, there is a risk of death from electric shock.

- ▶ Never use the factory-installed connection cable with earthed plug when installing the product in a moist environment.
- ▶ Connect the product using a fixed connection and an electrical partition with a contact opening of at least 3 mm (e.g. fuses or power switches).
- ▶ Use a flexible line for the mains connection line, which is routed through the cable duct into the product.

1. Open the electronics box. (→ Page 16)
2. Detach the plug from the PCB slot for the power supply (X1).
3. Unscrew the plug of the factory-installed power supply cable, if installed.
4. Instead of the factory-installed power supply cable, if installed, use a suitable three-core power supply cable which complies with the relevant standards.
5. Carry out the wiring. (→ Page 16)
6. Close the electronics box.
7. Observe the flue-gas connection that is required on a room-sealed air/flue gas installation. (→ Page 15)

### 5.10.5 Connecting controllers to the electronic system

1. Install the controller if necessary.
2. Open the electronics box. (→ Page 16)
3. Carry out the wiring. (→ Page 16)
4. Observe the connection diagram in the appendix.

**Conditions:** Connecting a weather compensator or a room temperature controller via eBUS

- ▶ Connect the controller to the eBUS connection.
- ▶ Bridge the 24 V = RT connection (X100 or X106), if there is not already a bridge.

**Conditions:** Connecting a low-voltage controller (24 V)

- ▶ Remove the bridge and connect the controller to the 24 V = RT connection (X100 or X106).

**Conditions:** Connecting 230 volt controller

- ▶ Connect the switched live supply with the terminal marked RT at X1 (beside the LNPE connections) then remove the link at X100 (do NOT connect 230 volt to any other terminal than the RT connection).

## 6 Operation

**Conditions:** Connecting a limit thermostat for underfloor heating

- ▶ Remove the bridge and connect the limit thermostat to the **Burner off** connection.
- 5. Close the electronics box.
- 6. For multi-circuit controllers, change **D.018** from **Eco** (intermittently operating pump) to **Comfort** (continuously operating pump). (→ Page 26)

### 5.10.6 Connecting additional components

You can actuate an additional component with the aid of the auxiliary relay that is installed, and you can actuate two other components with the multi-functional module.

#### 5.10.6.1 Using the auxiliary relay

- 1. Connect an additional component directly to the integrated auxiliary relay using the grey plug on the PCB.
- 2. Carry out the wiring.
- 3. To start up the connected component, select the component in diagnostics code **D.026**. (→ Page 26)

#### 5.10.6.2 Using the VR 40 ("2 in 7" multi-functional module)

- 1. Install the components in accordance with the respective instructions.

**Conditions:** Components connected to relay 1

- ▶ Activate **D.027**. (→ Page 26)

**Conditions:** Components connected to relay 2

- ▶ Activate **D.028**. (→ Page 26)

### 5.10.7 Actuating the circulation pump according to requirements

- 1. Carry out the wiring.
- 2. Connect the supply line for the external button using terminals 1 ⊕ (0) and 6 (functional drawing) on the X41 edge connector, which is supplied with the controller.
- 3. Plug the edge connector into the PCB slot X41.

## 6 Operation



### 6.1 Operating concept

The operating concept and the read-off and setting facilities of the operator level are described in the operating instructions.

An overview of the reading and setting options for the installer level is included in the table in the appendix.

Installer level – Overview (→ Page 37)

### 6.2 Calling up the installer level

- 1. Only call up the installer level if you are a competent person.
- 2. Navigate to **Menu** → **Installer level** and confirm by pressing .
- 3. Set the value **17** (code) and confirm by pressing .

### 6.3 Live Monitor (status codes)

**Menu** → **Live monitor**

Status codes in the display provide information on the product's current operating mode.

Status codes – Overview (→ Page 44)

### 6.4 Setting the hot water temperature

**Applicability:** Product with integrated hot water generation

OR Product with hot water generation through external domestic hot water cylinder



#### **Danger!**

#### **Risk of death from legionella.**

Legionella multiply at temperatures below 60 °C.

- ▶ Ensure that the end user is familiar with all of the Anti-legionella measures in order to comply with the applicable regulations regarding legionella prevention.

- ▶ Set the hot water temperature.

**Conditions:** Water hardness: > 3.57 mol/m<sup>3</sup>

- Water temperature: ≤ 50 °C

## 7 Start-up

### 7.1 Carrying out the initial start-up

Initial start-up must be carried out by a customer service technician or an authorised competent person using the commissioning checklist. The commissioning checklist in the appendix (→ Page 57) of the installation instructions must be filled in and stored carefully along with the unit's documentation.

- ▶ Carry out the start-up procedure using the commissioning checklist in the appendix.
- ▶ Fill in and sign the commissioning checklist.

## 7.2 Switching the product on and off

- ▶ Press the on/off button on the product.
  - ◁ The basic display appears on the display.

## 7.3 Running the installation assistants

The installation assistant is displayed whenever the product is switched on until it has been successfully completed. It provides direct access to the most important check programmes and configuration settings for starting up the product.

To recheck and reset the most important system parameters, call up the **Appliance config.**

**Menu → Installer level → Appliance config.**

The settings options for more complex systems can be found in the **Diagnostics menu**.

**Menu → Installer level → Diagnostics menu**

- ▶ Press  to confirm installation assistant start-up.
  - ◁ All heating and hot water requests are blocked whilst the installation assistant is active.



### Note







If you do not confirm the launch of the installation assistant within 10 seconds of switching the system on, the basic display reappears.

- ▶ To access the next point, confirm by pressing  in each case.

### 7.3.1 Language

- ▶ Set the required language.
- ▶ To confirm the set language and to avoid unintentionally changing it, press  to confirm this twice.



If you have unintentionally set a language that you do not understand, proceed as follows to change it:

- ▶ Press and hold  and  at the same time.
- ▶ Also briefly press .
- ▶ Press and hold  and  until the display shows the language setting option.
- ▶ Select the required language.
- ▶ Press  twice to confirm this change.



### 7.3.2 Filling mode

Filling mode (check programme **P.06**) is activated automatically in the installation assistant for as long as the filling mode appears on the display.

### 7.3.3 Purging

1. Unlike in the **Check programs** menu, to purge the system, start check programme **P.00** by pressing  or .
2. If you need to change the circuit that is being purged, press .

### 7.3.4 Target feed temperature, hot water temperature, Comfort mode

1. To set the target flow temperature, hot water temperature and Comfort mode, use  and .
2. Press  to confirm this setting.

### 7.3.5 Heating partial load

The heating partial load of the product is set to **Auto** at the factory. The product independently determines the optimum heating output depending on the current heat demand of the system. You can retroactively change the setting in the **Diagnostics menu** under **D.000**.

### 7.3.6 Auxiliary relay and multi-functional module

1. If you have connected additional components to the product, assign these components to the individual relays.
2. In each case, confirm by pressing .



### Note

This setting can be retroactively changed in the **Diagnostics menu** using **D.026**, **D.027** and **D.028**.

### 7.3.7 Contact data

- ▶ If required, store your telephone number in the **Appliance config.** (max. 16 digits/no blank spaces). The operator can view the telephone number.

### 7.3.8 Ending the installation assistant

- ▶ Once you have run through the installation assistant successfully, confirm by pressing .
  - ◁ The installation assistant will close and will not launch again when the product is next switched on.

## 7.4 Restarting the installation assistants

**Menu → Installer level → Start inst. assistant**

You can restart the installation assistant at any time by calling it up in the menu.

## 7.5 Test programmes

**Menu → Installer level → Test programs**

As well as the installation assistants, you can also call up the following test programmes for start-up, service and troubleshooting.

- **Check programs**
- **Function menu**
- **Electronics self-test**



## 7 Start-up

### 7.6 Performing a gas family check



#### Danger! Risk of poisoning!

Inadequate combustion quality (CO), indicated by **F.92/93**, leads to an increased risk of poisoning.

- ▶ Make sure that the fault is completely eliminated before starting up the product for continuous operation.

Menu → Installer level → Test programs → Gas family check

The gas family check checks the product setting with regard to combustion quality.



#### Note

If additional condensing units are connected to the same flue gas pipe in the heating installation, ensure that none of these condensing units are in operation or start operating throughout the entire test programme, so that the test result is not distorted.

- ▶ Perform the gas family check as part of routine product maintenance work, after replacing components, carrying out work on the gas route and following gas conversion.

Result	Meaning	Measure
<b>F.92</b>	See the table of fault codes in the appendix	See the table of fault codes in the appendix
"Successful"	Combustion quality is good. Unit configuration matches the specified gas group.	None
"Warning"	Combustion quality inadequate. CO <sub>2</sub> content is incorrect.	Start check programme P.01 and adjust the CO <sub>2</sub> content with the adjusting screw in the Venturi.  If the correct CO <sub>2</sub> content cannot be set: Check that the gas restrictor is correct (yellow: G20 natural gas, blue: G25 natural gas, grey: Liquid gas) and undamaged.  Repeat the gas family check.
<b>F.93</b>	See the table of fault codes in the appendix	See the table of fault codes in the appendix



#### Note

It is not possible to perform CO<sub>2</sub> measurements during the gas family check.

### 7.7 Using check programmes

Menu → Installer level → Test programs → Check programs

By activating various check programmes, you can trigger special functions on the product.

Check programmes – Overview (→ Page 48)

### 7.8 Checking and treating the heating water/filling and supplementary water



#### Caution.

#### Risk of material damage due to poor-quality heating water

- ▶ Ensure that the heating water is of sufficient quality.

- ▶ Before filling or topping up the installation, check the quality of the heating water.

#### Checking the quality of the heating water

- ▶ Remove a little water from the heating circuit.
- ▶ Check the appearance of the heating water.
- ▶ If you ascertain that it contains sedimentary materials, you must desludge the installation.
- ▶ Use a magnetic rod to check whether it contains magnetite (iron oxide).
- ▶ If you ascertain that it contains magnetite, clean the installation and apply suitable corrosion-protection measures, or fit a magnetic filter.
- ▶ Check the pH value of the removed water at 25 °C.
- ▶ If the value is below 8.2 or above 10.0, clean the installation and treat the heating water.
- ▶ Ensure that oxygen cannot get into the heating water.

#### Checking the filling and supplementary water

- ▶ Before filling the installation, measure the hardness of the filling and supplementary water.

#### Treating the filling and supplementary water

- ▶ Observe all applicable national regulations and technical standards when treating the filling and supplementary water.

Provided the national regulations and technical standards do not stipulate more stringent requirements, the following applies:

You must treat the heating water in the following cases:

- If the entire filling and supplementary water quantity during the operating life of the system exceeds three times the nominal volume of the heating installation, or
- If the guideline values listed in the following table are not met, or
- If the pH value of the heating water is less than 8.2 or more than 10.0.

Total heating output	Water hardness at specific system volume <sup>1)</sup>					
	≤ 20 l/kW		> 20 l/kW ≤ 50 l/kW		> 50 l/kW	
kW	ppm CaCO <sub>3</sub>	mol/m <sup>3</sup>	ppm CaCO <sub>3</sub>	mol/m <sup>3</sup>	ppm CaCO <sub>3</sub>	mol/m <sup>3</sup>
< 50	< 300	< 3	200	2	2	0.02



Total heating output	Water hardness at specific system volume <sup>1)</sup>					
	≤ 20 l/kW		> 20 l/kW ≤ 50 l/kW		> 50 l/kW	
kW	ppm CaCO <sub>3</sub>	mol/m <sup>3</sup>	ppm CaCO <sub>3</sub>	mol/m <sup>3</sup>	ppm CaCO <sub>3</sub>	mol/m <sup>3</sup>
> 50 to ≤ 200	200	2	150	1.5	2	0.02
> 200 to ≤ 600	150	1.5	2	0.02	2	0.02
> 600	2	0.02	2	0.02	2	0.02

1) Nominal capacity in litres/heating output; in the case of multi-boiler systems, the smallest single heating output is to be used.



**Caution.**

**Risk of material damage if the heating water is treated with unsuitable additives.**

Unsuitable additives may cause changes in the components, noises in heating mode and possibly subsequent damage.

- ▶ Do not use any unsuitable frost and corrosion protection agents, biocides or sealants.

No incompatibility with our products has been detected to date with proper use of the following additives.

- ▶ When using additives, follow the manufacturer's instructions without exception.

We accept no liability for the compatibility of any additive or its effectiveness in the rest of the heating system.

**Additives for cleaning measures (subsequent flushing required)**

- Adey MC3+
- Adey MC5
- Fernox F3
- Sentinel X 300
- Sentinel X 400

**Additives intended to remain permanently in the installation**

- Adey MC1+
- Fernox F1
- Fernox F2
- Sentinel X 100
- Sentinel X 200

**Additives for frost protection intended to remain permanently in the installation**

- Adey MC ZERO
- Fernox Antifreeze Alpha 11
- Sentinel X 500

- ▶ If you have used the above-mentioned additives, inform the end user about the measures that are required.
- ▶ Inform the end user about the measures required for frost protection.

**7.9 Preventing low water pressure**

To ensure that the heating installation operates smoothly, the indicator on the pressure gauge must point to the upper half of the grey area or to the middle of the bar graph display in the display (marked by the dashed limit values) when the heating installation is cold. This corresponds to a filling pressure of between 0.1 MPa and 0.2 MPa (1.0 bar and 2.0 bar).

If the heating installation extends over several storeys, higher filling pressures may be required to avoid air entering the heating installation.

If the filling pressure falls below 0.08 MPa (0.8 bar), the product indicates low pressure by displaying a flashing pressure value. If the filling pressure falls below 0.05 MPa (0.5 bar), the product switches off. The display shows **F.22**.

- ▶ Top up the heating water to start the product up again.

The pressure value flashes in the display until a pressure of 0.11 MPa (1.1 bar) or higher has been reached.

**7.10 Flushing the heating installation for the first time ("cold")**



**Note**

The complete heating system must be flushed at least twice: Once with cold water and once with hot water in accordance with the following instructions.

1. Check whether all thermostatic radiator valves and both service valves on the product are open.
2. Connect a hose to the drain valve that is located at the lowest position in the heating system.
3. Open the radiator valves and the drain valves so that the water can drain quickly. Start at the next point in the system and open the purging valves on the radiators so that the contaminated water can completely drain.
4. Close the drain cocks.
5. Refill the heating system with water.
6. Check that the expansion relief valve of the heating system is functioning correctly by turning the handle on the valve.
7. Check the pressure in the heating system and top up with water if necessary.
8. Close the filling valve and the cold water valve.

**7.11 Filling the heating installation**

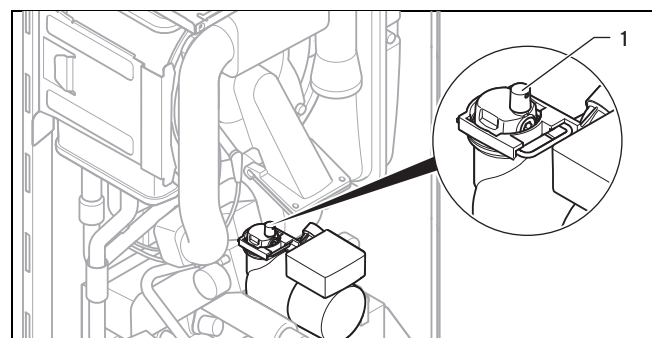

1. Flush the heating installation through.
2. Undo the cap of the automatic air vent (1) by one to two rotations and leave it open, as the product purges itself via the automatic air vent even in continuous mode.

## 7 Start-up

3. Select the check programme **P.06**.
  - ◁ The diverter valve moves to the mid-position, the pumps do not run and the product does not switch to heating mode.
4. Observe the information on treating heating water. (→ Page 20)
5. Check all connections and the entire system for leaks.

**Conditions:** Applies to: Products with integrated hot water generation

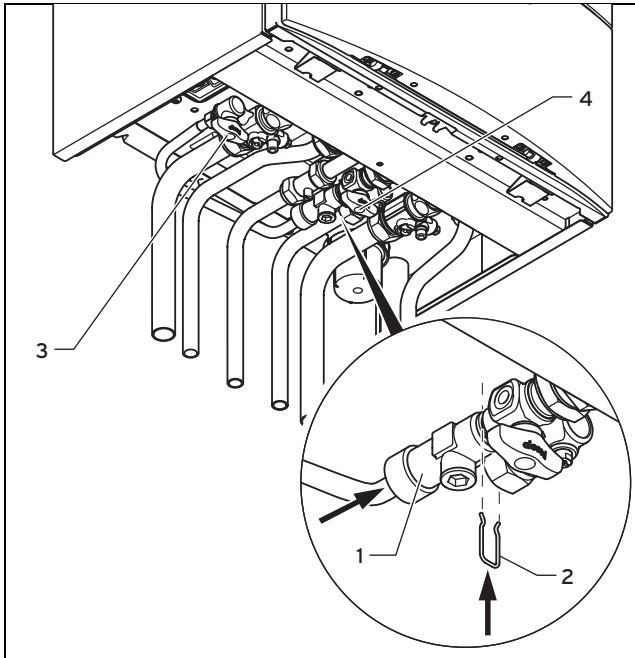

- ▶ Open all radiator valves (thermostatic radiator valves) of the heating installation.
- ▶ Fit the double non-return valve (1) of the filling line to the cold water stop valve and secure the valve with the spring clip (2).
- ▶ To fill, first open the stop valve (3).
- ▶ Open the stop valve (4) so that the water flows into the heating system. Fill the heating system.
- ▶ Purge the lowest radiator until water flows out of the purging valve without bubbles.
- ▶ Purge all other radiators until the entire heating system has been filled with water.
- ▶ Close all purging valves.
- ▶ Monitor the rising filling pressure in the heating installation.
- ▶ Fill with water until the required filling pressure is reached.
- ▶ After filling, close both stop valves and disconnect the filling device by removing the double non-return valve from the cold water stop valve.



### Note

Both stop valves must be closed while the heating system is operating and the filling line must be removed from the double non-return valve again.

**Conditions:** Applies to: Products with heating mode only

- ▶ Connect the filling and drainage tap in the heating installation to a heating water supply, if possible with the

cold water valve, in accordance with the relevant standards.

- ▶ Open the heating water supply.
- ▶ Open all radiator valves (thermostatic radiator valves) of the heating installation.
- ▶ If necessary, check that both service valves on the product are open.
- ▶ Slowly open the filling and drainage tap so that the water flows into the heating system.
- ▶ Purge the lowest radiator until water flows out of the purging valve without bubbles.
- ▶ Purge all other radiators until the entire heating system has been filled with water.
- ▶ Close all purging valves.
- ▶ Monitor the rising filling pressure in the heating installation.
- ▶ Fill with water until the required filling pressure is reached.
- ▶ Close the filling and drainage tap and the cold water valve.

### 7.12 Purging the heating installation

1. Select the check programme **P.00**.
  - ◁ The product does not start up, the internal pump operates intermittently and purges either the heating circuit or the hot water circuit.
  - ◁ The display shows the filling pressure of the heating installation.
2. Make sure that the filling pressure of the heating installation does not fall below the minimum filling pressure.
  - $\geq 0.08 \text{ MPa}$  ( $\geq 0.80 \text{ bar}$ )
  - ◁ At the end of the filling procedure, the filling pressure of the heating installation should be at least  $0.02 \text{ MPa}$  ( $0.2 \text{ bar}$ ) above the counter-pressure of the expansion vessel ("Exp") ( $P_{\text{Installation}} \geq P_{\text{Exp}} + 0.02 \text{ MPa}$  ( $0.2 \text{ bar}$ )).
3. If there is still too much air in the heating installation at the end of the check programme **P.00**, repeat the check programme.

### 7.13 Filling and purging the hot water system

**Applicability:** Product with integrated hot water generation

1. Open the cold water stop valve on the product.
2. Fill the hot water system by opening all the hot water draw-off valves until water escapes.

### 7.14 Filling the condensate trap

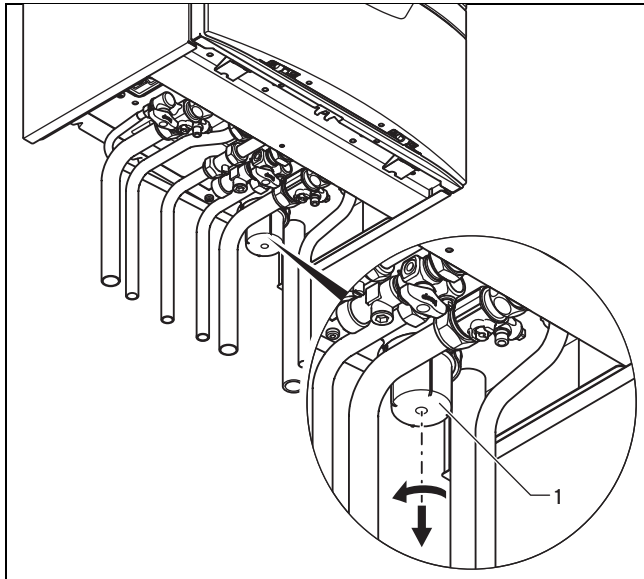

1. Remove the lower section from the condensate trap (1).
2. Fill the lower section with water up to 10 mm below the upper edge.
3. Attach the lower section to the condensate trap.

### 7.15 Gas inspection

#### 7.15.1 Checking the factory-set gas ratio setting



**Caution.**  
**Risk of material damage caused by making unauthorised settings.**

- ▶ Never modify the factory setting of the gas pressure regulator of the gas valve.

- ▶ Before you start up the product, compare the gas group information on the identification plate with the gas group available at the installation site.

**Conditions:** The product design is not compatible with the local gas group

Only Vaillant Service Solutions may perform a gas conversion.

If a gas conversion to liquid gas has been carried out, the smallest possible partial load is higher than is shown on the display. The correct values can be found in the Technical data in the appendix.

- ▶ Call Vaillant Service Solutions (0330 1003 143).
- ▶ Do not start up the product.

**Conditions:** The product design is compatible with the local gas group

- ▶ Proceed as described below.

#### 7.15.2 Checking the leak-tightness of the flue gas installation and flue gas recirculation

1. Check the flue gas installation is intact in accordance with the latest gas safe technical bulletin and information supplied in the installation instructions.
2. For extended flue gas installations check for flue gas recirculation using the air analysis point.
3. Use a flue gas analyser.
4. If you discover CO or CO<sub>2</sub> in the supply air, search for the leak in the flue gas installation or for signs of flue gas recirculation.
5. Eliminate the damage properly.
6. Check again whether the supply air contains any CO or CO<sub>2</sub>.
7. If you cannot eliminate the damage, do not start up the product.

#### 7.15.3 Checking the gas flow rate

The gas flow rate has been set during production and does not require adjustment. With the front casing fitted check the gas flow rate of the boiler as follows:

- ▶ Start up the product with the check programme **P.01**.
- ▶ In addition, ensure that maximum heat can be dissipated into the heating system by turning up the room thermostat.
- ▶ Wait at least 5 minutes until the boiler has reached its operating temperature.
- ▶ Ensure that all other gas appliances in the property are turned off.
- ▶ Measure the gas flow rate at the gas meter.
- ▶ Compare the measured values with the corresponding values in the table.

Qnw from the data plate	H gas in m <sup>3</sup> /h		
	Nom.	+5%	-10%
15.3	1.62	1.70	1.46
18.4	1.95	2.05	1.76
24.7	2.61	2.74	2.35
25.7	2.72	2.86	2.45
28.6	3.03	3.18	2.73
30.6	3.24	3.40	2.92
35.7	3.78	3.97	3.40

**Conditions:** Gas flow rate not in the permissible range

- ▶ Check all of the piping and ensure that the gas flow rates are correct.
- ▶ Only put the product into operation once the gas flow rates have been corrected.

**Conditions:** Gas flow rate in the permissible range

- ▶ End the check programme **P.01**.
- ▶ Allow the boiler to cool down by allowing pump overrun to operate for a minimum of 2 minutes.
- ▶ Record the boiler maximum gas flow rate onto the Benchmark gas boiler commissioning checklist.

## 7 Start-up

### 7.15.4 Checking the gas flow pressure

1. Ensure that the gas inlet working pressure can be obtained with all other gas appliances in the property working.
2. Close the gas isolator cock.

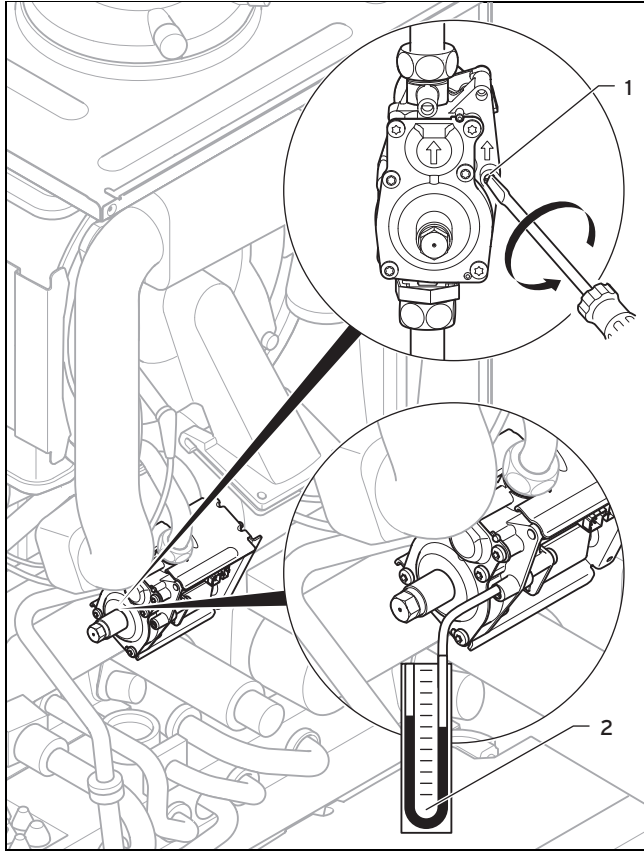

3. Use a screwdriver to undo the measuring nipple screw (1) (lower screw) at the gas valve.
4. Connect a pressure gauge (2) to the measuring nipple (1).
5. Open the gas isolator cock.
6. Start up the product with the check programme P.01.
7. In addition, ensure that maximum heat can be dissipated into the heating system by turning up the room thermostat.
8. With the boiler operating at full load check that the gas inlet working pressure at the reference test point complies with the requirements.
  - Permissible gas flow pressure for operation with G20 natural gas: 1.3 ... 2.3 kPa (13.0 ... 23.0 mbar)
  - Permissible gas flow pressure for operation with G31 liquid gas: 2.3 ... 4.3 kPa (23.0 ... 43.0 mbar)
9. Should the pressure recorded at the reference test point in the boiler be lower than indicated check if there is any blockage in the pipework or if the pipework is undersized.

**Conditions:** Gas flow pressure not in the permissible range



#### Caution.

#### Risk of material damage and operating faults caused by incorrect gas connection pressure.

If the gas connection pressure lies outside the permissible range, this can cause operating faults in and damage to the product.

- ▶ Do not make any adjustments to the product.
- ▶ Do not start up the product.

- ▶ If you cannot correct the failure, notify the gas supply company and proceed as follows:
- ▶ End the check programme P.01.
- ▶ Allow the boiler to cool down by allowing pump overrun to operate for a minimum of two minutes.
- ▶ Close the gas isolator cock.
- ▶ Remove the pressure gauge and retighten the sealing screw (1) for the measuring nipple.
- ▶ Open the gas isolator cock.
- ▶ Check the measuring nipple for gas tightness.
- ▶ Close the gas isolator cock.
- ▶ Install the front casing.
- ▶ Disconnect the product from the power mains.
- ▶ You must not start up the boiler.

**Conditions:** Gas flow pressure in the permissible range

- ▶ End the check programme P.01.
- ▶ Allow the boiler to cool down allowing pump overrun to operate for a minimum of two minutes.
- ▶ Close the gas isolator cock.
- ▶ Remove the pressure gauge and retighten the sealing screw (1) for the measuring nipple.
- ▶ Open the gas isolator cock.
- ▶ Check the measuring nipple for gas tightness.
- ▶ Install the front casing.
- ▶ Reset boiler controls for normal operation.
- ▶ Record the appliance gas inlet working pressure (kPa resp. mbar) in the Benchmark gas boiler commissioning checklist.

### 7.15.5 Checking the CO<sub>2</sub> content and, if necessary, adjusting it (air index setting)

1. Start up the product with the check programme P.01.
2. Wait at least five minutes until the product reaches its operating temperature.
3. Measure the CO<sub>2</sub> and CO/CO<sub>2</sub> content at the flue gas analysis point.
4. Compare the measured value with the corresponding value in the table.

Settings	Unit	G20 natural gas	G31 liquid gas
CO <sub>2</sub> after 5 minutes in full load mode with front casing closed	Vol.-%	9.2 ± 1.0	10.4 ± 0.5



Settings	Unit	G20 natural gas	G31 liquid gas
CO <sub>2</sub> after 5 minutes in full load mode with front casing removed	Vol.-%	9.0 ± 1.0	10.2 ± 0.5
Set for Wobbe index W <sub>0</sub>	kWh/m <sup>3</sup>	14.09	21.34
O <sub>2</sub> after 5 minutes in full load mode with front casing closed	Vol.-%	4.5 ± 1.8	5.1 ± 0.8
CO value with full load	ppm	≤ 250	≤ 250
CO/CO <sub>2</sub>		≤ 0.0031	≤ 0.0026

**Conditions:** The CO<sub>2</sub> content must be adjusted

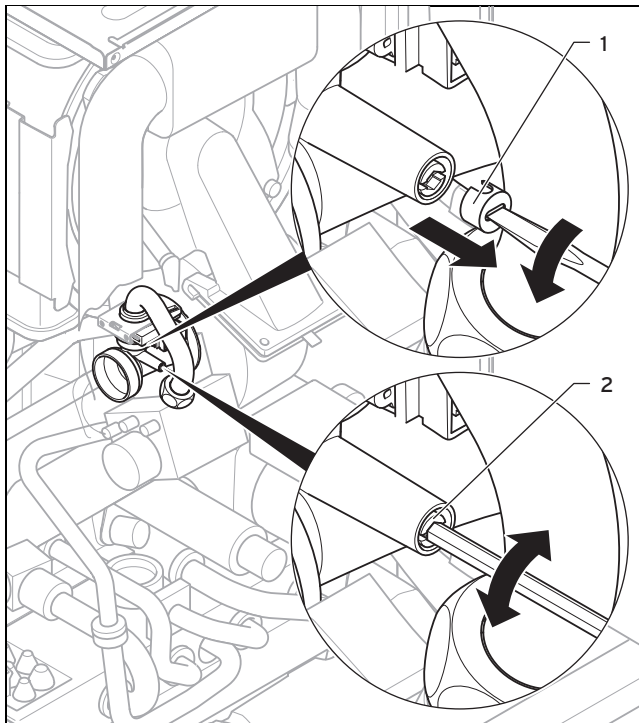

- ▶ Pierce the covering cap (1) at the mark using a small flat-blade screwdriver and unscrew it.
- ▶ After performing the adjustments, tilt the air intake pipe back up.
- ▶ Check the CO<sub>2</sub> content again.
- ▶ If necessary, repeat the setting process.
- ▶ Set the CO<sub>2</sub> content (value with front casing removed) by turning the screw (2).
  - Higher CO<sub>2</sub> content: Turn anti-clockwise
  - Lower CO<sub>2</sub> content: Turn clockwise
- ▶ For natural gas only: Only perform the adjustment in increments of 1 turn and wait approx. 1 minute after each adjustment until the value stabilises.
- ▶ For liquid gas only: Only perform the adjustment in small increments (approx. 1/2 turn), and wait approx. 1 minute after each adjustment until the value stabilises.
- ▶ Check the CO<sub>2</sub> content again.
- ▶ If necessary, repeat the setting process.
- ▶ Press  (**Cancel**) once the adjustments have been made.
- ▶ If an adjustment is not possible in the specified adjustment range, you must not start up the product.
- ▶ If this is the case, inform Customer Service.

- ▶ Screw the covering cap back in.
- ▶ Install the front casing.

## 7.16 Checking leak-tightness

- ▶ Check the gas pipe, the heating circuit and the domestic hot water circuit for leak-tightness.
- ▶ Check that the air/flue pipe has been installed correctly.

**Conditions:** Room-sealed operation

- ▶ Check whether the vacuum chamber has been closed tightly.

### 7.16.1 Checking the heating mode

1. Make sure that there is a heat requirement.
2. Call up **Live monitor**.
  - ◁ If the product is working correctly, the display shows **S.04**.

### 7.16.2 Checking the hot water generation

**Applicability:** Product with integrated hot water generation

1. Open a hot water valve all the way.
2. Call up **Live monitor**.
  - ◁ If the hot water generation is working correctly, **S.14** appears in the display.

### 7.16.3 Checking the hot water generation

**Applicability:** Product with heating mode only

1. Ensure that the cylinder charging mode is requesting heat.
2. Call up **Live monitor**.
  - ◁ If the cylinder is charged correctly, the display shows **S.24**.
3. If you have connected a controller which can be used to set the hot water temperature, set the hot water temperature on the boiler to the maximum possible temperature.
4. Adjust the target temperature for the connected domestic hot water cylinder to the controller.
  - ◁ The product adopts the set target temperature that is set on the controller.

## 7.17 Thoroughly flushing the heating installation ("hot")

1. Operate the appliance until the boiler and the heating system are up to temperature.
2. Check the heating system for leaks.
3. Connect a hose to the drain valve located at the lowest position of the heating system.
4. Shut off the boiler, open the drain valve and all purge valves on the radiators and allow the water to flow out of the heating system and the boiler quickly and fully.
5. Close the drain valve.
6. Fill the heating system again with water as described in Filling the heating installation (→ Page 21) and Purging the heating installation (→ Page 22).

## 8 Adapting the unit to the heating installation

- Re-fill the system until the system design pressure of 0,1 MPa (1,0 bar) is attained.



### Note

The actual reading on the digital pressure gauge should ideally be 0,05 MPa (0,5 bar) plus an additional pressure corresponding to the highest point of the system above the base of the boiler – 10 m head equals an additional 1 bar reading on the pressure gauge. The minimum pressure should not be less than 0,1 MPa (1 bar) in any installation. If the system is to be treated with an inhibitor it should be applied at this stage in accordance with the manufacturer's instructions. Further information can be obtained from Sentinel, Betz Dearborn Ltd., Tel: 0151 420 9595, or Fernox, Alpha– Fry technologies. Tel: 0870 8700362.

- Install the front casing.

## 8 Adapting the unit to the heating installation

To reset the most important system parameters, use the **Appliance config.** menu point.

**Menu** → **Installer level** → **Appliance config.**

Or manually relaunch the installation assistant.

**Menu** → **Installer level** → **Start inst. assistant**

You can find setting options in the **Diagnostics menu**.

**Menu** → **Installer level** → **Diagnostics menu**

Overview of diagnostics codes (→ Page 39)

### 8.1 Burner anti-cycling time

To prevent frequent switching on and off of the burner and thus prevent energy losses, an electronic restart lockout is activated for a specific period each time the burner is switched off. The burner anti-cycling time is only active for the heating mode. Hot water handling during a burner anti-cycling time does not affect the time function element (default setting: 20 mins).

#### 8.1.1 Setting the burner anti-cycling time

- Navigate to **Menu** → **Installer level** → **Diagnostics menu** → **D.002 Max. anti-cycl. time: Heating** and confirm by pressing .
- Set the burner anti-cycling time and confirm by pressing .

T <sub>Flow</sub> (target) [°C]	Set maximum burner anti-cycling time [min]						
	1	5	10	15	20	25	30
30	2.0	4.0	8.5	12.5	16.5	20.5	25.0
35	2.0	4.0	7.5	11.0	15.0	18.5	22.0
40	2.0	3.5	6.5	10.0	13.0	16.5	19.5
45	2.0	3.0	6.0	8.5	11.5	14.0	17.0

T <sub>Flow</sub> (target) [°C]	Set maximum burner anti-cycling time [min]						
	1	5	10	15	20	25	30
50	2.0	3.0	5.0	7.5	9.5	12.0	14.0
55	2.0	2.5	4.5	6.0	8.0	10.0	11.5
60	2.0	2.0	3.5	5.0	6.0	7.5	9.0
65	2.0	1.5	2.5	3.5	4.5	5.5	6.5
70	2.0	1.5	2.0	2.5	2.5	3.0	3.5
75	2.0	1.0	1.0	1.0	1.0	1.0	1.0

T <sub>Flow</sub> (target) [°C]	Set maximum burner anti-cycling time [min]					
	35	40	45	50	55	60
30	29.0	33.0	37.0	41.0	45.0	49.5
35	25.5	29.5	33.0	36.5	40.5	44.0
40	22.5	26.0	29.0	32.0	35.5	38.5
45	19.5	22.5	25.0	27.5	30.5	33.0
50	16.5	18.5	21.0	23.5	25.5	28.0
55	13.5	15.0	17.0	19.0	20.5	22.5
60	10.5	11.5	13.0	14.5	15.5	17.0
65	7.0	8.0	9.0	10.0	11.0	11.5
70	4.0	4.5	5.0	5.5	6.0	6.5
75	1.0	1.0	1.0	1.0	1.0	1.0

#### 8.1.2 Resetting the remaining burner anti-cycling time

##### 1. Alternatives 1 / 2

- Navigate to **Menu** → **Reset anti-cycl. time**.

◀ The current burner anti-cycling time appears in the display.

- Press  to reset the burner anti-cycling time.

##### 1. Alternatives 2 / 2

- Press .

#### 8.2 Setting the maintenance interval

- Navigate to **Menu** → **Installer level** → **Diagnostics menu** → **D.084 Maintenance in** and confirm by pressing .
- Set the maintenance interval (operating hours) until the next maintenance work is due and confirm by pressing .

Heat demand	Number of persons	Guideline value for burner operating hours until the next inspection/maintenance work is due for an average operating time of one year (dependent upon the system type)
5.0 kW	1 - 2	1050 h
	2 - 3	1150 h
10.0 kW	1 - 2	1500 h
	2 - 3	1600 h
15.0 kW	2 - 3	1800 h
	3 - 4	1900 h



## Adapting the unit to the heating installation 8

Heat demand	Number of persons	Guideline value for burner operating hours until the next inspection/maintenance work is due for an average operating time of one year (dependent upon the system type)
20.0 kW	3 - 4	2600 h
	4 - 5	2700 h
25.0 kW	3 - 4	2800 h
	4 - 6	2900 h
> 27.0 kW	3 - 4	3000 h
	4 - 6	3000 h

### 8.3.1.3 Pump characteristic line for VU 306, VUW 306, VUW 356

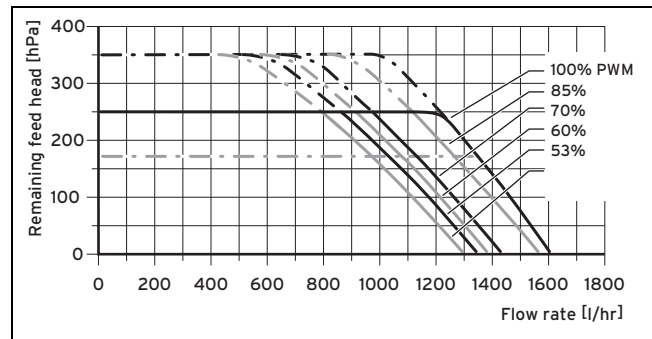

### 8.3.1.4 Pump characteristic line for VUW 246, VUW 326

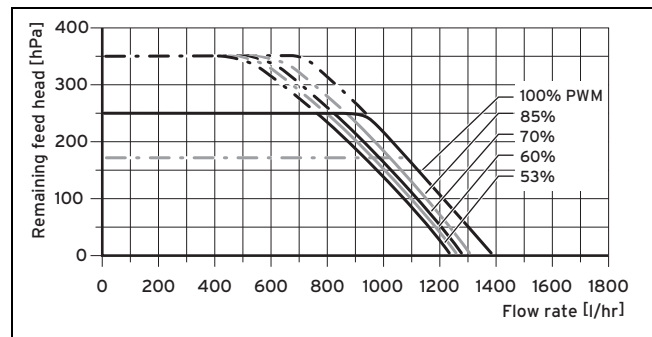

### 8.3 Setting the pump output

- Navigate to **Menu** → **Installer level** → **Diagnostics menu** → **D.014 Pump speed target value** and confirm by pressing .
- Set the required pump output.

**Conditions:** Low loss header installed

- Switch off the speed regulation and set the pump output to a fixed value.

### 8.3.1 Remaining feed head of the pump

#### 8.3.1.1 Pump characteristic line for VU 126, VU 156, VU 186

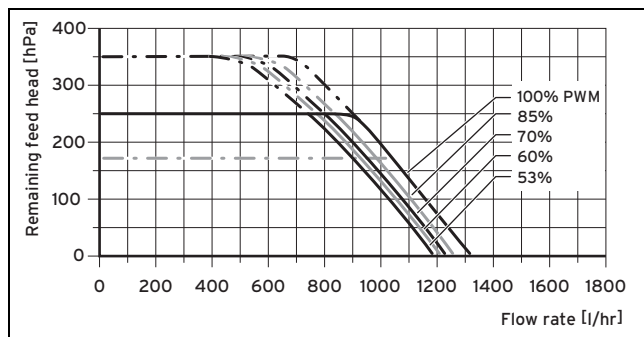

#### 8.3.1.5 Pump characteristic line for VU 376, VU 386, VUW 286, VUW 386

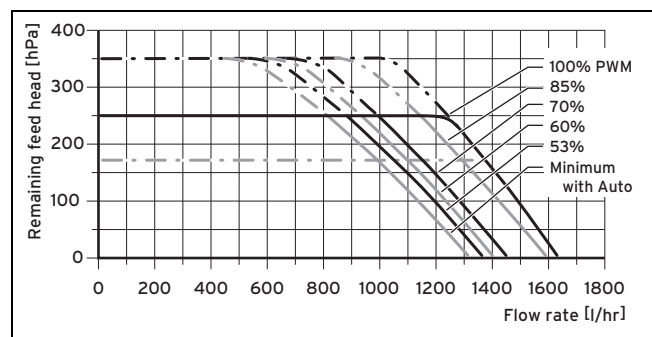

#### 8.3.1.2 Pump characteristic line for VU 246, VUW 196, VUW 256

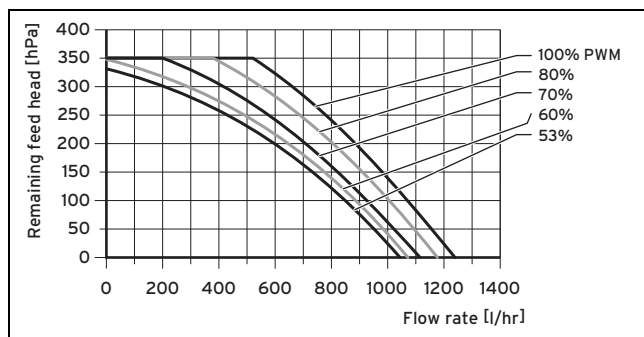

### 8.4 Setting the bypass valve



#### Caution.

#### Risk of material damage caused by incorrect setting of the high-efficiency pump

If the pressure at the bypass valve is increased (by turning it clockwise) and the pump output is set to less than 100%, the product may not operate correctly.

- In this case, set the pump output to 5 = 100% using diagnostics code D.014.

- Remove the front casing. (→ Page 12)

## 9 Troubleshooting

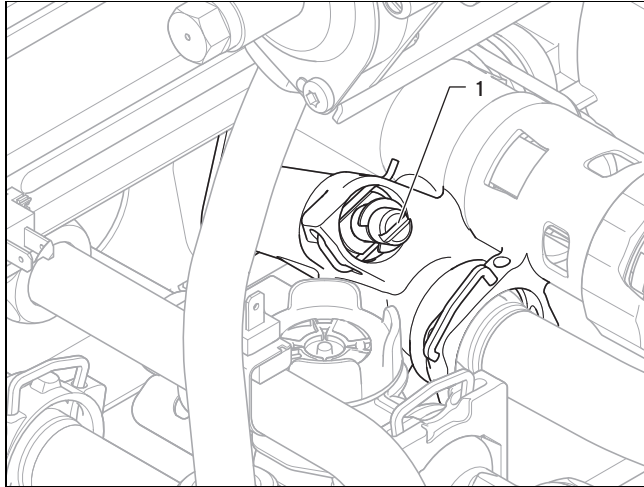

- ▶ Regulate the pressure using the adjusting screw (1).

Position of the adjusting screw	Pressure in MPa (mbar)	Notes/application
Right-hand stop (turned all the way down)	0.035 (350)	If the radiators do not heat up sufficiently at the default setting. In this case, you must set the pump to the maximum speed.
Mid-position (5 turns to the left)	0.025 (250)	Default setting
5 further turns to the left from the mid-position	0.017 (170)	If noises are produced in the radiators or radiator valves

- ▶ Install the front casing.

### 8.5 Handing the product over to the operator

- ▶ When you have finished the installation, affix the enclosed sticker (which requests that the user reads the instructions) to the front of the product in the operator's language.
- ▶ Explain to the operator how the safety devices work and where they are located.
- ▶ Inform the operator how to handle the product.
- ▶ In particular, draw attention to the safety information which the operator must follow.
- ▶ Inform the operator that they must have the product maintained in accordance with the specified intervals.
- ▶ Pass all of the instructions and documentation for the product to the operator for safe-keeping.
- ▶ Inform the operator about measures taken to ensure the supply of combustion air and flue gas guiding, and instruct the operator that he must not make any changes.
- ▶ Inform the operator that they must not store or use explosive or highly flammable substances (such as petrol, paper or paint) in the installation room of the product.
- ▶ Complete and sign off the Benchmark commissioning check list.
- ▶ Complete and sign off the guarantee documentation.

## 9 Troubleshooting

### 9.1 Checking service messages

appears if you have set a maintenance interval, for example, and this has passed or a service message is issued. The product is not in fault mode.

- ▶ Navigate to **Menu** → **Live monitor** and confirm by pressing .

**Conditions:** S.40 is displayed

The product is in Comfort protection mode. The product continues to run with restricted comfort after it has detected a fault.

- ▶ To establish whether or not a component is defective, read the fault memory. (→ Page 28)



#### Note

If no fault message is present, the product will automatically switch back to normal operating mode after a certain time.

### 9.2 Eliminating faults

- ▶ If fault messages (**F.XX**) occur, eliminate the faults by checking the table in the appendix or using the function menu or the check programmes.

Overview of fault codes (→ Page 45)

Function menu – Overview (→ Page 48)

Check programmes – Overview (→ Page 48)

If several faults occur at the same time, the display shows the corresponding fault messages for two seconds each in alternation.

- ▶ Press (max. three times) to restart the product.
- ▶ If you are unable to eliminate the fault and the fault recurs despite reset attempts, contact customer service.

### 9.3 Calling up and clearing the fault memory

The last 10 fault messages are stored in the fault memory.

- ▶ Navigate to the **Fault list** menu.
  - ◀ The display shows the number of faults that have occurred, the fault numbers and the corresponding plain text display.
- ▶ Press or to call up individual fault messages.
- ▶ Press twice to delete the fault list.

### 9.4 Resetting parameters to factory settings

1. Navigate to **Menu** → **Installer level** → **Diagnostics menu** → **D.096 Reset to factory settings?** and confirm by pressing .
2. Set the diagnostics code to 1, and confirm by pressing .

## 9.5 Preparing the repair work

1. Decommission the product.
2. Disconnect the product from the power mains.
3. Remove the front casing. (→ Page 12)
4. Close the gas isolator cock.
5. Close the service valves in the heating flow and in the heating return.
6. Close the service valve in the cold water pipe.
7. Drain the product if you want to replace water-bearing components of the product.
8. Make sure that water does not drip on live components (e.g. the electronics box).
9. Use only new seals.

### 9.5.1 Procuring spare parts

The original components of the product were also certified by the manufacturer as part of the declaration of conformity. If you use other, non-certified or unauthorised parts during maintenance or repair work, this may void the conformity of the product and it will therefore no longer comply with the applicable standards.

We strongly recommend that you use original spare parts from the manufacturer as this guarantees fault-free and safe operation of the product. To receive information about the available original spare parts, contact the contact address provided on the reverse of these instructions.

- ▶ If you require spare parts for maintenance or repair work, use only the spare parts that are permitted for the product.

## 9.6 Replacing defective components

### 9.6.1 Replacing the burner

1. Remove the compact thermal module. (→ Page 33)

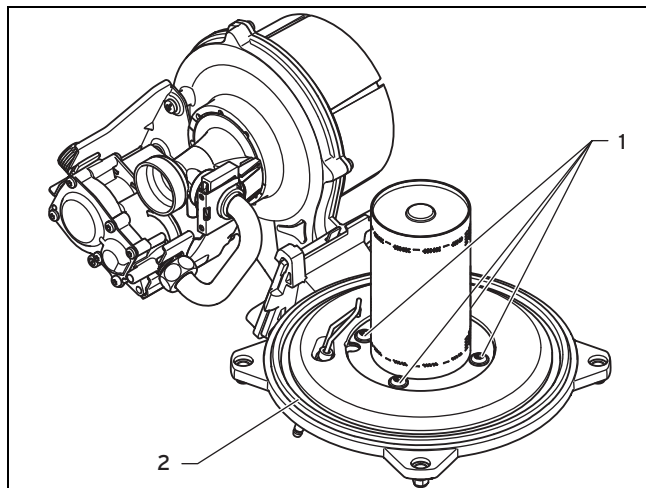

2. Undo the four screws (1) on the burner.
3. Remove the burner.
4. Install a new seal (2) on the new burner.
5. Install the compact thermal module. (→ Page 35)

### 9.6.2 Replacing the fan

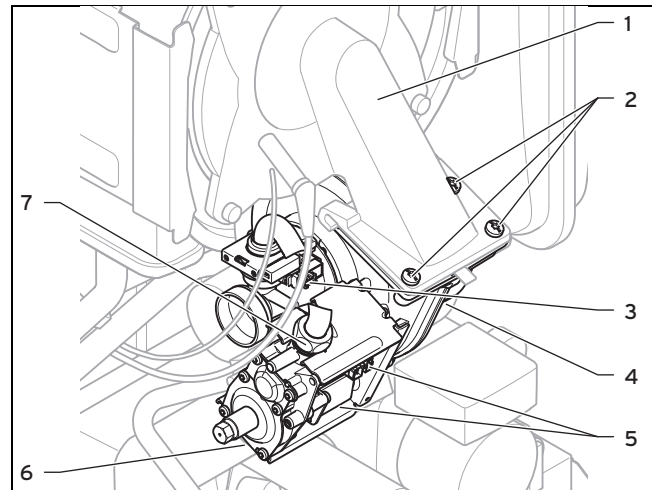

1. Remove the air intake pipe.
2. Remove the three plugs from the gas valve (5).
3. Remove the plug from the sensor on the Venturi (3) by pushing in the latching lug.
4. Remove the plug/plugs (4) (depending on the unit design) from the fan motor by pushing in the latching lug in each case.
5. Unscrew the two cap nuts (7) and (6) on the gas valve. Use an open-ended spanner to counterhold the opposite side of the gas valve when unscrewing.
6. Unscrew the three screws (2) between the mixture pipe (1) and the fan flange.

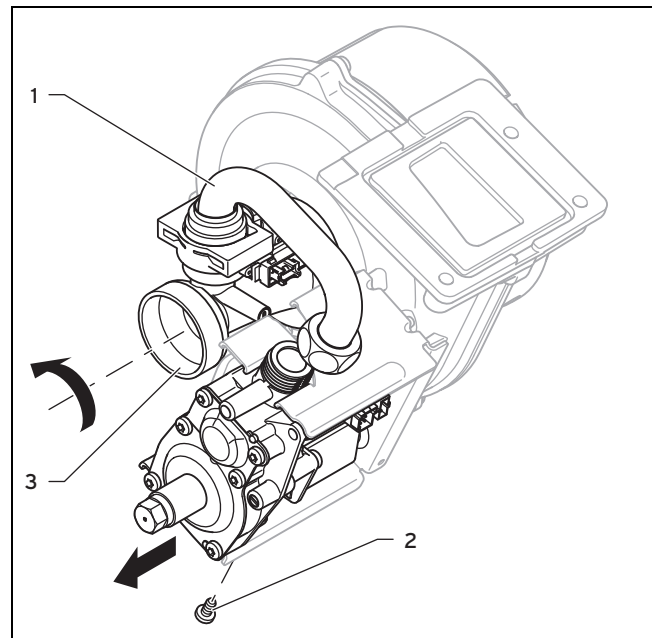

7. Remove the entire unit comprising the fan, Venturi and gas valve from the product.
8. Unscrew the gas valve fixing screw (2) from the retainer.
9. Remove the gas valve from the retainer.
10. Remove the Venturi (3), including the gas connection pipe (1), from the fan by turning the bayonet fitting on the Venturi anti-clockwise as far as it goes and removing it straight from the fan.

## 9 Troubleshooting

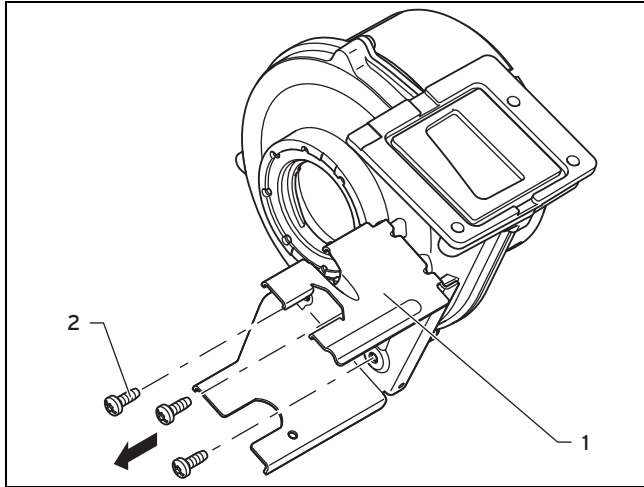

11. Remove the gas valve retainer (1) from the fan by unscrewing the three screws (2).
12. Replace the defective fan.

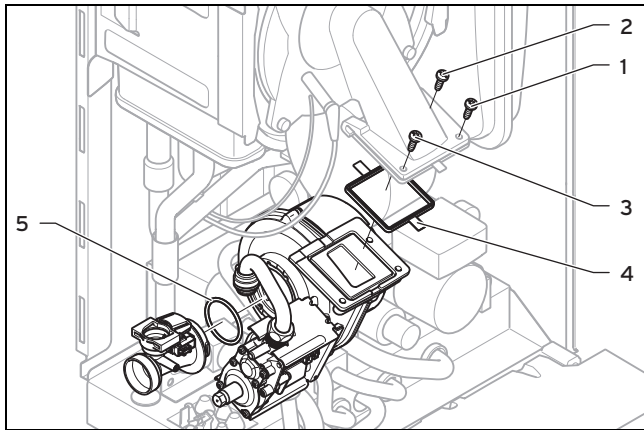

13. Refit the components in the reverse order. New seals (4) and (5) must be used for this. Pay attention to the order in which the three screws between the fan and the mixture pipe are screwed in, as per the numbering (1), (2) and (3).
14. Screw the flexible gas line to the gas valve. Use new seals for this.
15. When tightening the cap nut on the gas valve, use an open-ended spanner to counterhold the opposite side of the gas valve.
16. Perform a gas family check after installing the new fan. (→ Page 20)

### 9.6.3 Replacing the gas valve



#### Note

To replace the gas valve, you will need a Torx T20. To replace the gas valve directly from the front, you will need an offset screwdriver or a Torx T20 socket. If you do not have access to an offset screwdriver or the like, you must first remove the entire unit comprising the fan with gas valve before you can remove the gas valve from the retainer.

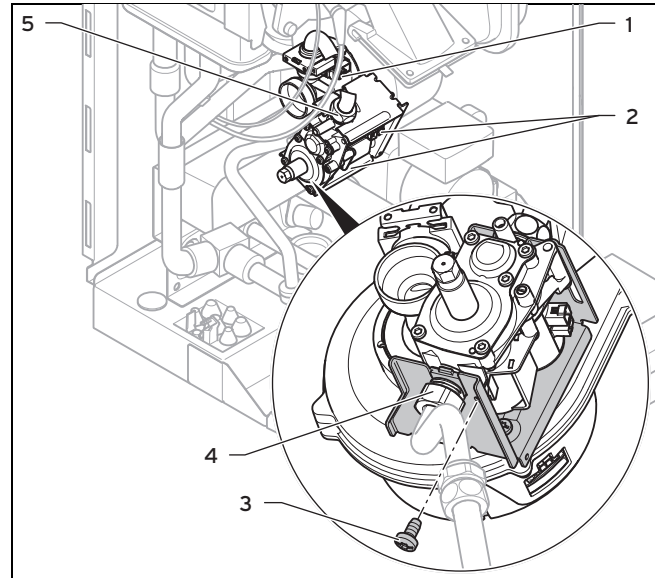

1. Remove the air intake pipe.
2. Remove the three plugs from the gas valve (2).
3. Remove the plug from the sensor on the Venturi (1) by pushing in the latching lug.
4. Unscrew the two cap nuts (5) and (4) on the gas valve. Use an open-ended spanner to counterhold the opposite side of the gas valve (4) and (5) when unscrewing.
5. Either remove the unit comprising the fan with gas valve (Replacing the fan (→ Page 29)), or use an offset screwdriver or Torx T20 socket to unscrew the fixing screw of gas valve (3) from the retainer.



#### Note

The screw in the gas valve retainer secures the gas valve against turning and must be screwed back in once the gas valve has been replaced.

6. Remove the gas valve from the retainer.
7. Reinstall the new gas valve in the reverse order. Use new seals for this.
8. When tightening the cap nuts on the gas valve, use an open-ended spanner to counterhold the opposite side of the gas valve (4) and (5).
9. After installing the new gas valve, perform a leak-tightness test (→ Page 25), gas family check (→ Page 20) and gas ratio setting (→ Page 23).



## 9.6.4 Replacing the Venturi

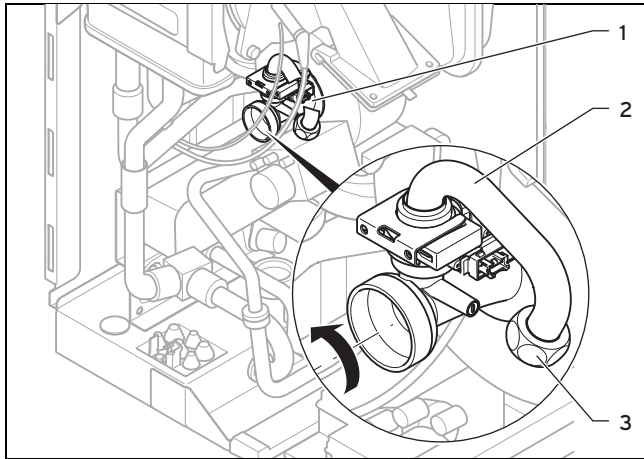

1. Remove the air intake pipe.
2. Remove the plug from the sensor on the Venturi (1) by pushing in the latching lug.
3. Unscrew the cap nuts (3) of the gas connection pipe (2) on the gas valve.
4. Remove the Venturi, including the gas connection pipe, from the fan by turning the bayonet fitting on the Venturi anti-clockwise as far as it goes and removing it straight from the fan.

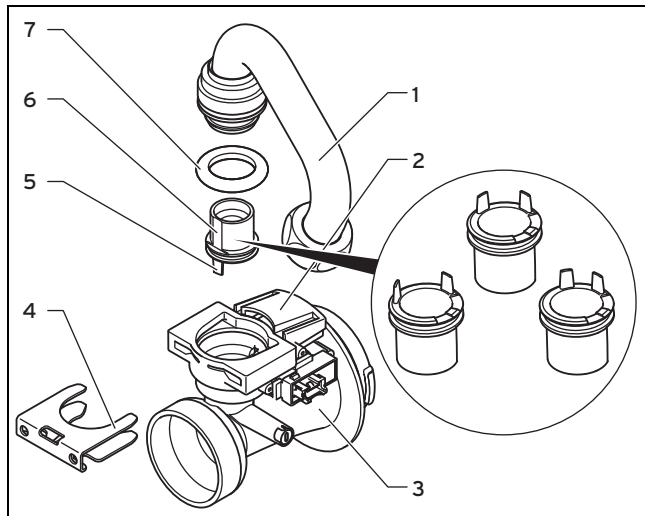

5. Remove the gas connection pipe (1) from the Venturi (3) by removing the clamp (4) and pulling the gas connection pipe out vertically. Dispose of the seal (7).
6. Pull the gas restrictor (6) straight off, and keep it for re-use.
7. Check whether the Venturi is free of residue at the gas inlet side.



**Caution.**  
**Risk of material damage to the product.**

Lubricant can block function-related channels in the Venturi.

- ▶ Do not use lubricant when installing the gas restrictor.

8. Ensure that you use the correct gas restrictor (colour coding and position of pins on the underside of the gas

restrictor). The colour of the gas restrictor must match the colour of the coding resistor on the PCB.

9. Insert the gas restrictor for the gas group in question into the new Venturi (yellow: G20 natural gas, grey: Liquid gas).
10. When inserting the gas restrictor, ensure that the gas restrictor is correctly aligned using the indicated position marks on the upper side of the Venturi and also the positioning pins (5) on the underside of the gas restrictor.
11. Refit the components in the reverse order. Use new seals for this.
12. After installing the new Venturi, carry out a gas ratio setting. (→ Page 23)
13. If you cannot adjust the CO<sub>2</sub> content, the gas restrictor has been damaged during installation. In this case, replace the gas restrictor with an appropriate spare part.
14. Perform a gas family check. (→ Page 20)

## 9.6.5 Replacing the heat exchanger

1. Drain the product. (→ Page 35)
2. Remove the compact thermal module. (→ Page 33)
3. Detach the condensate drain hose from the heat exchanger.

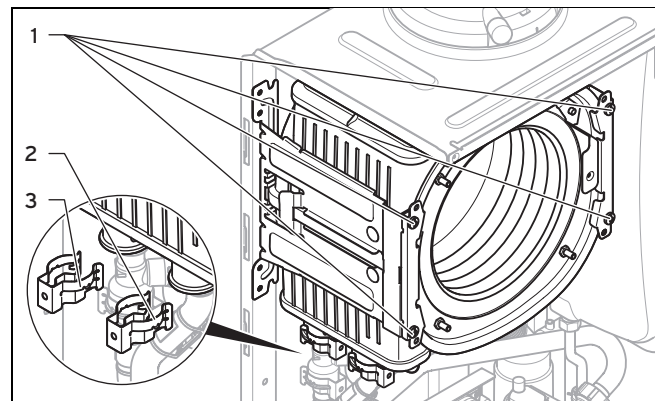

4. Remove the clamps (2) and (3) from the flow connection and the return connection.
5. Detach the flow connection.
6. Detach the return connection.
7. Remove two screws (1) on each of the two retainers.



## 9 Troubleshooting

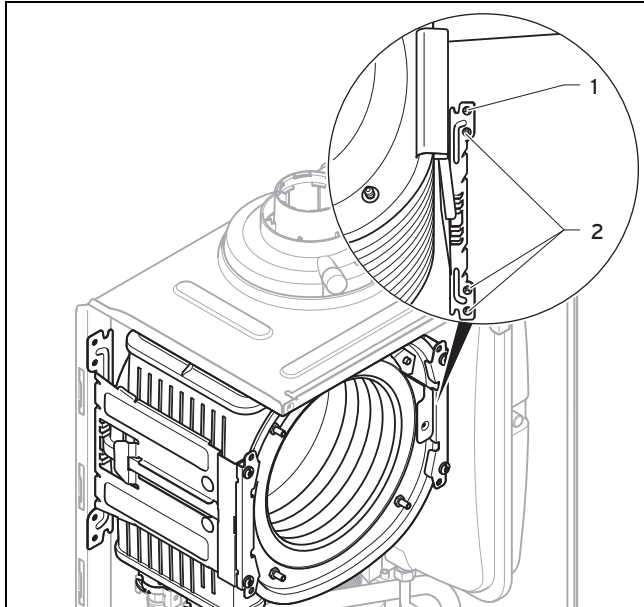

8. Remove the lower three screws **(2)** on the rear section of the retainer.
9. Swing the retainer to the side around the top screw **(1)**.
10. Pull the heat exchanger downwards and to the right, and remove it from the product.
11. Install the new heat exchanger in reverse order.
12. Replace the seals.



### Note

Instead of grease, use only water or commercially available soft soap to aid installation.

13. Insert the flow and return connections into the heat exchanger as far as they will go.
14. Make sure that the brackets are seated correctly on the flow and return connections.
15. Install the compact thermal module. (→ Page 35)
16. Fill and purge the product and, if necessary, the heating installation. (→ Page 21)

### 9.6.6 Replacing the expansion vessel

1. Drain the product. (→ Page 35)

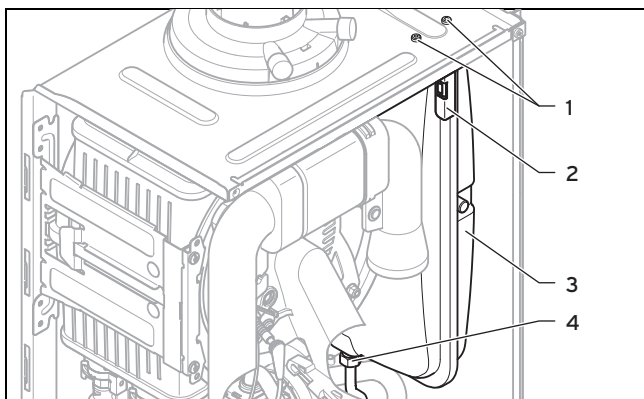

2. Undo the screwed connection **(4)**.
3. Remove both screws **(1)** on the support plate **(2)**.
4. Remove the support plate **(2)**.
5. Pull out the expansion vessel **(3)** towards the front.

6. Insert the new expansion vessel into the product.
7. Screw the new expansion vessel to the water connection. Use a new seal for this.
8. Attach the support plate using both screws **(1)**.
9. Fill and purge the product and, if necessary, the heating installation. (→ Page 21)

### 9.6.7 Replacing the PCB or the display



### Note

If you only replace one component, when the product is switched on, the new component adopts the parameters that were previously set from the component that was not replaced.

1. Open the electronics box. (→ Page 16)
2. Replace the PCB or display according to the assembly and installation instructions supplied.

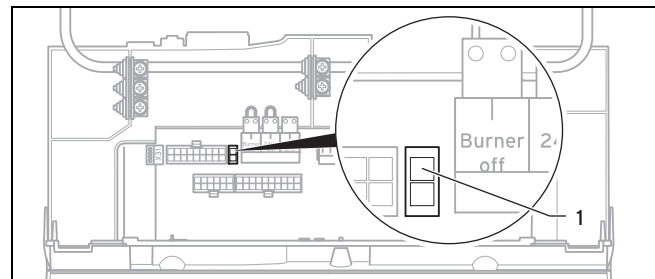



3. If you are replacing the PCB, remove the coding resistance **(1)** (plug X24) from the old PCB and plug the plug onto the new PCB.
4. Close the electronics box.

### 9.6.8 Replacing the PCB and the display

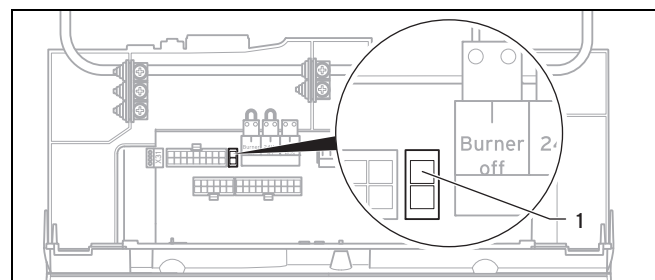
1. Open the electronics box. (→ Page 16)
2. Replace the PCB and display according to the assembly and installation instructions supplied.



3. Remove the coding resistance **(1)** (plug X24) from the old PCB and plug the plug into the new PCB.
4. Close the electronics box.
5. Press the on/off button on the product. (→ Page 19)
  - ◁ After switching on, the product switches directly to the menu to select the language. The default language setting is English.
6. Select the required language and confirm by pressing .
  - ◁ You are automatically taken to **D.093** to set the device specific number.
7. Set the correct value for the relevant product type in accordance with the table below and confirm by pressing .

## Product type number

VU 126/5-5 (H-GB) ecoTEC plus 612	1
VU 156/5-5 (H-GB) ecoTEC plus 615	3
VU 186/5-5 (H-GB) ecoTEC plus 618	4
VU 186/5-5 (P-GB) ecoTEC plus 618	4
VU 246/5-5 (H-GB) ecoTEC plus 624	9
VU 306/5-5 (H-GB) ecoTEC plus 630	14
VU 306/5-5 (P-GB) ecoTEC plus 630	14
VU 386/5-5 (H-GB) ecoTEC plus 637	20
VUW 196/5-5 (H-GB) ecoTEC plus 825	6
VUW 246/5-5 (H-GB) ecoTEC plus 832	10
VUW 246/5-5 (P-GB) ecoTEC plus 832	10
VUW 306/5-5 (H-GB) ecoTEC plus 835	13
VUW 286/5-5 (H-GB) ecoTEC plus 838	17

- < The electronics are now set to the product type and the parameters of all diagnostics codes are set to default settings.
- < The installation assistant starts.

8. Make the system-specific settings.

### 9.7 Completing repair work

1. Establish the power supply.
2. Switch the product back on if this has not yet been done. (→ Page 19)
3. Install the front casing.
4. Open all service valves and the gas isolator cock.

### 9.8 Checking the product for leak-tightness

- ▶ Check that the product is leak-tight. (→ Page 25)

## 10 Inspection and maintenance

- ▶ You must carry out an annual inspection of the product. The annual inspection can be effectively performed without removing components by requesting data from the DIA system, carrying out the simple visual checks indicated in the table in the appendix and performing a flue gas measurement. The maintenance intervals and their scope are determined by the heating engineer based on the condition of the boiler found during the inspection. All inspection and maintenance work should be performed in the order specified in the table in the appendix.

During any inspection and maintenance or after change of parts of the combustion circuit, the following must be checked:

- The boiler has been installed in accordance with the relevant installation instructions.
  - The integrity of the flue gas installation and flue seals is in accordance with the relevant flue installation instructions enclosed.
  - Visual, the integrity of the boiler combustion circuit and relevant seals (paying particular attention to the burner door seal).
  - The gas inlet working pressure at maximum rate.
  - The gas flow rates.
  - Correctness of electrical, water and gas connections.
  - Correctness of the water pressure.
  - The condition of the whole system, in particular the condition of radiator valves, evidence of leakage from the heating system and dripping taps.
- ▶ Correct any faults before proceeding.

### 10.1 Function menu

**Menu → Installer level → Test programs → Function menu**

The function menu allows you to actuate and test individual components in the heating installation.

Function menu – Overview (→ Page 48)

### 10.2 Electronics self-test

**Menu → Installer level → Test programs → Electronics self-test**

You can use the electronics self-test to check the PCB.

### 10.3 Removing the compact thermal module



#### Note

The compact thermal module consists of five main components:

- Speed-regulated fan,
- Gas valve including support plate,
- Venturi including mass flow sensor and gas connection pipe,
- Burner flange,
- Premix burner.



#### Danger!

**Risk of death and risk of material damage caused by hot flue gas.**

The seal, insulating mat and self-locking nuts on the burner flange must not be damaged. Otherwise, hot flue gases may escape and cause personal injury and material damage.

- ▶ Replace the seal each time you open the burner flange.
- ▶ Replace the self-locking nuts on the burner flange each time you open the burner flange.
- ▶ If the insulating mat on the burner flange or on the back wall of the heat exchanger shows signs of damage, replace the insulating mat.

## 10 Inspection and maintenance

1. Switch off the product using the on/off button.
2. Close the gas isolator cock.
3. Remove the front casing. (→ Page 12)
4. Tilt the electronics box forward.

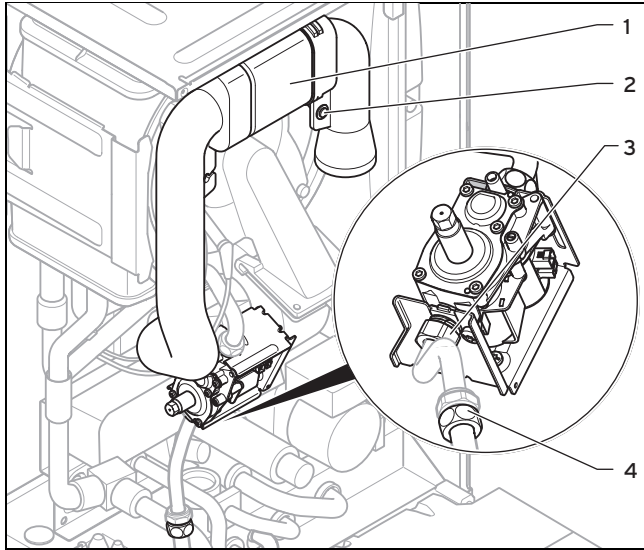

5. Unscrew the retaining screw (2) and remove the air intake pipe (1) from the intake stub.
6. Unscrew either the cap nut on the gas valve (3) or the cap nut (4) between the corrugated gas pipe and the fixed gas pipe.

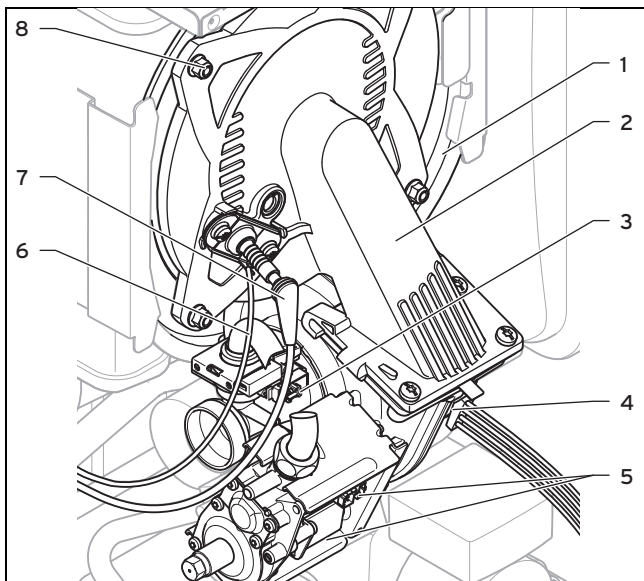

7. Remove the plugs of the ignition line (7) and of the ground connection (6) from the ignition electrode.
8. Remove the plug (4) from the fan motor by pushing in the latching lug.
9. Remove the three plugs from the gas valve (5).
10. Remove the plug from the Venturi (3) by pushing in the latching lug.
11. Release the cable harness from the clip on the gas valve retainer.
12. Unscrew the four nuts (8).
13. Remove the entire compact thermal module (2) from the heat exchanger (1).
14. Check the burner and the heat exchanger for damage and dirt.

15. If necessary, clean or replace the components according to the following sections.
16. Fit a new burner flange seal.
17. Check the insulating mat on the burner flange and on the back wall of the heat exchanger. If you notice any signs of damage, replace the relevant insulating mat.

### 10.4 Cleaning the heat exchanger

1. Protect the folded down electronics box against sprayed water.

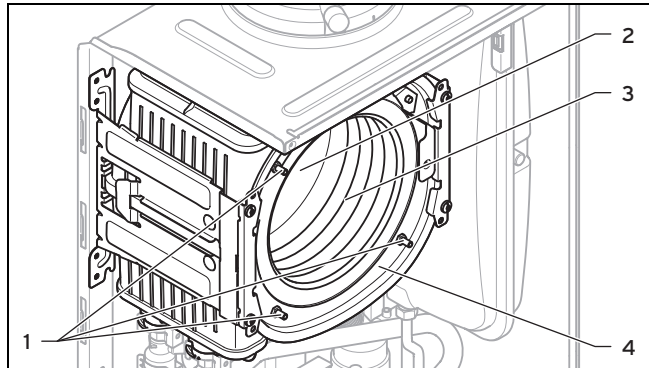

2. Never undo the four nuts on the stud bolt (1) or tighten them.
3. Clean the heating coil (3) of the heat exchanger (4) using water or, if required, vinegar (to a maximum of 5% acid). Allow the vinegar to act on the heat exchanger for 20 minutes.
4. Rinse away any loose dirt with a sharp jet of water or use a plastic brush. Do not point the water jet directly at the insulating mat (2) on the back of the heat exchanger.
  - ◁ The water flows out of the heat exchanger through the condensate trap.

### 10.5 Checking the burner

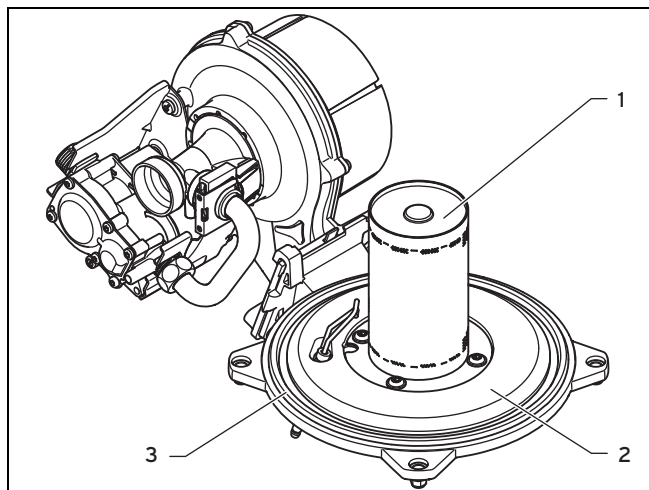

1. Check the surface of the burner (1) for damage. If you see any damage, replace the burner.
2. Fit a new burner flange seal (3).
3. Check the insulating mat (2) on the burner flange. If you notice any signs of damage, replace the insulating mat.

## 10.6 Cleaning the condensate trap

1. Remove the lower section of the condensate trap (1).
2. Flush out the lower section with water.
3. Fill the lower section with water up to about 10 mm below the upper edge.
4. Attach the lower section to the condensate trap.

## 10.7 Cleaning the filter in the cold water inlet

**Applicability:** Product with integrated hot water generation

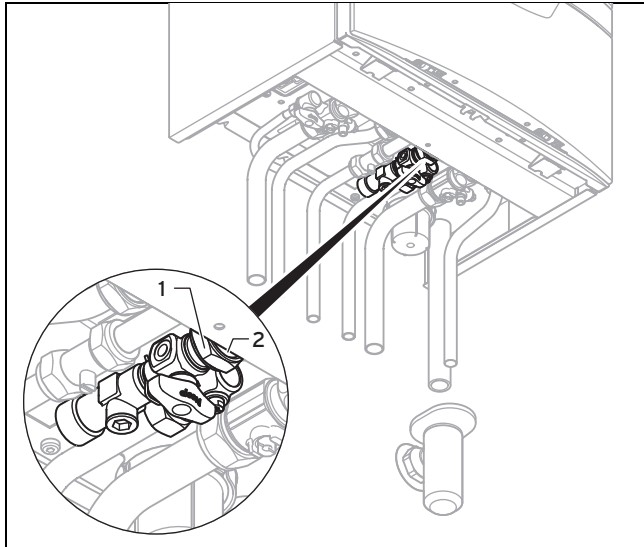

1. Close the cold water stop valve.
2. Drain the product on the hot water side.
3. Unscrew the cap nut (2) and the lock nut (1) from the product's casing.

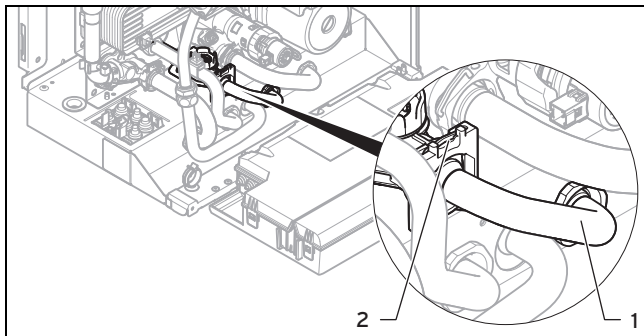

4. Tilt the electronics box forward.
5. Remove the clamp (2).
6. Remove the pipe (1) from the product.
7. Rinse the filter under a jet of water, holding it against the direction of flow.
8. If the filter is damaged or it can no longer be cleaned sufficiently, you must replace the filter.
9. Refit the pipe.
10. Reinsert the clamp.
11. Always use new seals and retighten the cap nuts and the lock nut.
12. Open the cold water stop valve.

## 10.8 Installing the compact thermal module

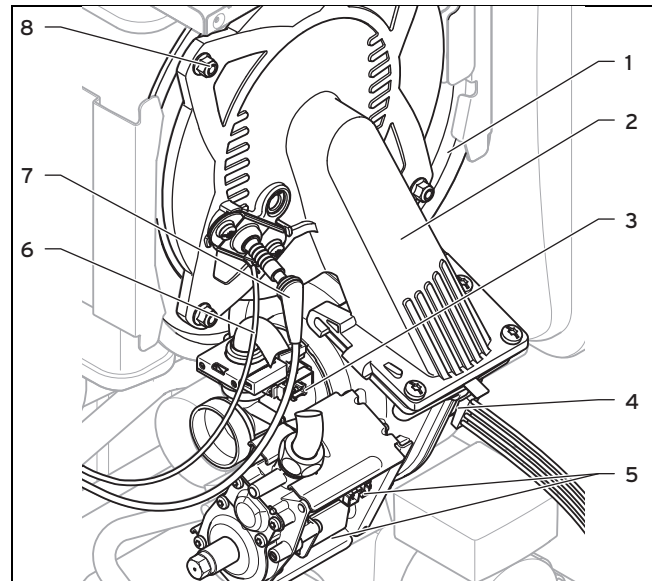

1. Connect the compact thermal module (2) to the heat exchanger (1).
2. Tighten the four nuts (8) in a cross-wise pattern until the burner flange fits closely and uniformly onto the mating surfaces (if a torque spanner is available, set at 6 Nm).
3. Reconnect the plugs (3) to (7).
4. Connect the gas line using a new seal. In the process, secure the gas pipe against twisting.
5. Open the gas isolator cock.
6. Make sure that there are no leaks.
7. Check that the sealing ring in the air intake pipe is positioned correctly in the seal seat.
8. Reconnect the air intake pipe to the intake nozzle.
9. Secure the air intake pipe with the retaining screw.
10. Check the gas flow pressure.

## 10.9 Draining the product

1. Close the service valves of the product.
2. Start the check programme **P.06** (diverter valve mid-position).
3. Open the drain valves.
4. Make sure that the cap of the automatic air vent on the internal pump is open so that the product can be drained fully.

## 10.10 Checking the pre-charge pressure for the internal expansion vessel

1. Close the service valves and drain the product.
2. Measure the pre-charge pressure of the expansion vessel at the vessel valve.

**Conditions:** Pre-charge pressure < 0.075 MPa (0.75 bar)

- Ideally, you should top up the expansion vessel with nitrogen. Otherwise, top it up with air. Ensure that the drain valve is open when topping up.
3. If water escapes from the valve of the expansion vessel, you must replace the expansion vessel. (→ Page 32)
  4. Fill the heating installation. (→ Page 21)
  5. Purge the heating installation. (→ Page 22)

# 11 Decommissioning

## 10.11 Completing inspection and maintenance work

Once you have completed all maintenance work:

- ▶ Check the gas flow pressure. (→ Page 24)
- ▶ Check the CO<sub>2</sub> content and, if necessary, adjust it (air index setting). (→ Page 24)
- ▶ If required, reset the maintenance interval. (→ Page 26)

## 10.12 Checking the product for leak-tightness

- ▶ Check that the product is leak-tight. (→ Page 25)

# 11 Decommissioning

## 11.1 Temporarily decommissioning the product

- ▶ Press the on/off button.
  - ◁ The display goes out.
- ▶ Close the gas isolator cock.
- ▶ For products with hot water generation and products with a connected domestic hot water cylinder, you must also close the cold water stop valve.

## 11.2 Decommissioning the product

- ▶ Press the on/off button.
  - ◁ The display goes out.
- ▶ Disconnect the product from the power mains.
- ▶ Close the gas isolator cock.
- ▶ Close the cold water stop valve.
- ▶ Drain the product. (→ Page 35)

# 12 Recycling and disposal

## Disposing of the packaging

- ▶ Dispose of the packaging correctly.
- ▶ Observe all relevant regulations.

# 13 Customer service

To ensure regular servicing, it is strongly recommended that arrangements are made for a Maintenance Agreement. Please contact Vaillant Service Solutions for further details:

Telephone: 0330 100 3461



## Appendix

## A Installer level – Overview

Setting level	Values		Unit	Increment, select, explanation	Default setting
	Min.	Max.			
Installer level →					
Enter code	00	99	–	1 (competent person code 17)	–
Installer level → Fault list →					
F.XX - F.XX <sup>1</sup>	Current value		–	–	–
Installer level → Test programs →					
Gas family check	Current value		–	LPG, natural gas	–
Installer level → Test programs → Check programs →					
P.00 Purging	–	–	–	Yes, No	–
P.01 Maximum load	–	–	–	Yes, No	–
P.02 Minimum load	–	–	–	Yes, No	–
P.06 Filling mode	–	–	–	Yes, No	–
Installer level → Test programs → Function menu →					
T.01 Internal pump	–	–	–	On, Off	–
T.02 3-way valve	–	–	–	On, Off	–
T.03 Fan	–	–	–	On, Off	–
T.04 Cylinder charging pump	–	–	–	On, Off	–
T.05 Circulation pump	–	–	–	On, Off	–
T.06 External pump	–	–	–	On, Off	–
T.08 Burner	–	–	–	On, Off	–
Installer level → Test programs → Electronics self-test →					
Self-test	–	–	–	Yes, No	–
Installer level → Appliance config. →					
Language	–	–	–	Languages available for selection	Country-specific
Target flow temp.	30	75	°C	1	–
DHW temperature	30	60	°C	1 Product with hot water generation or connected domestic hot water cylinder	–
Comfort mode	–	–	–	On, Off	Off
Auxiliary relay	1	10	–	1 = Circulation pump 2 = External pump 3 = Cylinder charging pump 4 = Extractor hood 5 = External solenoid valve 6 = External fault message 7 = Solar pump (not active) 8 = eBUS remote control (not active) 9 = Legionella protection pump (not active) 10 = Solar valve (not active)	2
<sup>1</sup> Fault lists are only displayed, and can only be deleted, if faults have occurred.					

## Appendix

Setting level	Values		Unit	Increment, select, explanation	Default setting
	Min.	Max.			
<b>Accessory relay 1</b>	1	10	–	1 = Circulation pump 2 = External pump 3 = Cylinder charging pump 4 = Extractor hood 5 = External solenoid valve 6 = External fault message 7 = Solar pump (not active) 8 = eBUS remote control (not active) 9 = Legionella protection pump (not active) 10 = Solar valve (not active)	2
<b>Accessory relay 2</b>	1	10	–	1 = Circulation pump 2 = External pump 3 = Cylinder charging pump 4 = Extractor hood 5 = External solenoid valve 6 = External fault message 7 = Solar pump (not active) 8 = eBUS remote control (not active) 9 = Legionella protection pump (not active) 10 = Solar valve (not active)	2
<b>Heating partial load</b>	–	–	kW	Partial load only, full load only, auto	Auto
<b>Contact details</b>	Phone number	–	–	0 – 9	Auto
<b>Factory setting</b>	–	–	–	On, Off	–
<b>Installer level → Diagnostics menu →</b>					
<b>D.XXX - D.XXX</b>	Current value	–	–	–	–
<b>Installer level → Start inst. assistant →</b>					
<b>Language</b>	–	–	–	Languages available for selection	Country-specific
<b>Filling mode: 3-way valve is in mid-position</b>	0	2	–	0 = Normal operating mode 1 = Mid-position (parallel operation) 2 = Permanent heating mode position	–
<b>Purge program: Select circ. using +/-</b>	–	–	–	Automatic adaptive purging of the heating circuit and hot water circuit Not active Active	–
<b>Target flow temp.</b>	30	75	°C	1	–
<b>DHW temperature</b>	35	60	°C	1 Product with hot water generation	–
<b>Comfort mode</b>	–	–	–	On, Off	–
<b>Heating partial load</b>	–	–	kW	Partial load only, full load only, auto	Auto
<b>Auxiliary relay</b>	1	10	–	1 = Circulation pump 2 = External pump 3 = Cylinder charging pump 4 = Extractor hood 5 = External solenoid valve 6 = External fault message 7 = Solar pump (not active) 8 = eBUS remote control (not active) 9 = Legionella protection pump (not active) 10 = Solar valve (not active)	2
*Fault lists are only displayed, and can only be deleted, if faults have occurred.					

Setting level	Values		Unit	Increment, select, explanation	Default setting
	Min.	Max.			
Accessory relay 1	1	10	–	1 = Circulation pump 2 = External pump 3 = Cylinder charging pump 4 = Extractor hood 5 = External solenoid valve 6 = External fault message 7 = Solar pump (not active) 8 = eBUS remote control (not active) 9 = Legionella protection pump (not active) 10 = Solar valve (not active)	2
Accessory relay 2	1	10	–	1 = Circulation pump 2 = External pump 3 = Cylinder charging pump 4 = Extractor hood 5 = External solenoid valve 6 = External fault message 7 = Solar pump (not active) 8 = eBUS remote control (not active) 9 = Legionella protection pump (not active) 10 = Solar valve (not active)	2
Contact details	Phone number		–	0-9	–
End the installation assistant?	–	–	–	Yes, No	–
*Fault lists are only displayed, and can only be deleted, if faults have occurred.					

## B Overview of diagnostics codes



### Note

Since the code table is used for various products, some codes may not be visible for the product in question.

Code	Parameter	Values or explanations	Default setting	Own setting
D.000	Heating partial load	Adjustable heating partial load in kW Auto: Product automatically adjusts max. partial load to current system demand	Auto	
D.001	Pump overrun: Heating	1 ... 60 min	5 min	
D.002	Max. anti-cycl. time: Heating	2 ... 60 min	20 min	
D.003	Outlet temperature actual value	In °C		Not adjustable
D.004	Cylinder temperature actual value	In °C		Not adjustable
D.005	Heating target flow temperature	In °C; the maximum value that is set in D.071 and is restricted by means of an eBUS control if such a control is connected		Not adjustable
D.006	Outlet temperature target value	35 ... 65 °C		Not adjustable
D.007	Comfort mode target value APC target value Cylinder temperature target value	Product with integrated domestic hot water generation, and product with integrated domestic hot water generation and shift-load cylinder 35 ... 65 °C Product with heating mode only Frost protection is at 15 °C, then 40 to 70 °C (max. temperature can be adjusted under D.020)		Not adjustable
D.008	Controller 3-4	Room thermostat open (no heat requirement) Room thermostat closed (heat requirement)		Not adjustable
D.009	eBUS controller target value	In °C		Not adjustable

## Appendix

Code	Parameter	Values or explanations	Default setting	Own setting
D.010	Internal pump	On, Off		Not adjustable
D.011	External pump	On, Off		Not adjustable
D.012	Cyl. charging pump	On, Off		Not adjustable
D.013	Circulation pump	On, Off		Not adjustable
D.014	Pump speed target value	Target value of internal high-efficiency pump in %. Possible settings: 0 = Auto 1 = 53 2 = 60 3 = 70 4 = 85 5 = 100	0 = Auto	
D.015	Pump speed actual value	Actual value for internal high-efficiency pump in %		Not adjustable
D.016	Controller 24 V DC: Heating mode	Heating mode off/on		Not adjustable
D.017	Control type	Control type: 0 = Flow, 1 = Return Return: Automatic detection function for heating output inactive. Max. possible heating partial load when <b>D.000</b> is on <b>Auto</b> .	0 = Flow	
D.018	Pump operating mode	1 = Comfort (continuously operating pump) Internal pump is switched on when the heating flow temperature is not at <b>Heating off</b> and the heat requirement is enabled via an external controller 3 = Eco (intermittently operating pump) Internal pump is switched on every 25 minutes for 5 minutes once the overrun time has elapsed	3 = Eco	
D.019	Pump operating mode: 2-stage pump	Setting for two-stage pump operating mode 0: Burner mode stage 2, pump flow/overrun stage 1 1: Heating mode and pump flow/overrun stage 1, hot water handling mode stage 2 2: Automatic heating mode, pump flow/overrun stage 1, hot water handling mode stage 2 3: Always stage 2 4: Automatic heating mode, pump flow/overrun stage 1, hot water handling mode stage 1	2	
D.020	Max. DHW temperature target value	Adjustment range: 50-70 °C ( <b>actoSTOR</b> 65 °C)	65 °C	
D.022	DHW demand	On, Off		Not adjustable
D.023	Heating mode status	Heating on, heating off (summer mode)		Not adjustable
D.025	Ext. eBUS signal: Cylinder charging	On, Off		Not adjustable
D.026	Auxiliary relay	1 = Circulation pump 2 = External pump 3 = Cylinder charging pump 4 = Extractor hood 5 = External solenoid valve 6 = External fault message 7 = Solar pump (not active) 8 = eBUS remote control (not active) 9 = Legionella protection pump (not active) 10 = Solar valve (not active)	2 = External pump	

Code	Parameter	Values or explanations	Default setting	Own setting
D.027	Accessory relay 1	Switching of relay 1 on the VR 40 "2 in 7" multi-functional module 1 = Circulation pump 2 = External pump 3 = Cylinder charging pump 4 = Extractor hood 5 = External solenoid valve 6 = External fault message 7 = Solar pump (not active) 8 = eBUS remote control (not active) 9 = Legionella protection pump (not active) 10 = Solar valve (not active)	2 = External pump	
D.028	Accessory relay 2	Switching of relay 2 on the VR 40 "2 in 7" multi-functional module 1 = Circulation pump 2 = External pump 3 = Cylinder charging pump 4 = Extractor hood 5 = External solenoid valve 6 = External fault message 7 = Solar pump (not active) 8 = eBUS remote control (not active) 9 = Legionella protection pump (not active) 10 = Solar valve (not active)	2 = External pump	
D.029	Water circulation vol. actual value	Actual value in m <sup>3</sup> /h		Not adjustable
D.033	Fan speed target value	In rpm		Not adjustable
D.034	Fan speed actual value	In rpm		Not adjustable
D.035	3-way valve position	Heating mode Parallel operation (mid-position) DHW mode		Not adjustable
D.036	DHW flow rate	In l/min		Not adjustable
D.039	Solar inlet temp. actual value	Actual value in °C		Not adjustable
D.040	Flow temperature actual value	Actual value in °C		Not adjustable
D.041	Return temperature actual value	Actual value in °C		Not adjustable
D.044	Ionisation value actual value	Display field 0 to 1020 > 800 no flame < 400 good flame		Not adjustable
D.046	Pump mode	0 = Relay with disable facility 1 = PWM with disable facility	0 = Relay with disable facility	
D.047	Current outside temperature	(with Vaillant weather compensator) Actual value in °C		Not adjustable
D.050	Offset min. speed	In rpm, setting range: 0 to 3000	Nominal value set in factory	
D.051	Offset max. speed	In rpm, setting range: -990 to 0	Nominal value set in factory	
D.058	Solar post-heating	0 = Solar post-heating deactivated 3 = DHW activation target value minimum 60 °C, thermostatic mixer valve required between product and draw-off point	0 = Solar post-heating deactivated	
D.060	Number of safety therm. shutdowns	Number of shutdowns		Not adjustable



## Appendix

Code	Parameter	Values or explanations	Default setting	Own setting
D.061	No. of shut-downs in ign. flame controller	Number of unsuccessful ignitions in the last attempt		Not adjustable
D.064	Avg. ignition time	In seconds		Not adjustable
D.065	Max. ignition time	In seconds		Not adjustable
D.067	Remaining anti-cycl. time for heating	In minutes		Not adjustable
D.068	Number of first start attempts	Number of unsuccessful ignitions		Not adjustable
D.069	Number of second start attempts	Number of unsuccessful ignitions		Not adjustable
D.070	3-way valve operation	0 = Normal operating mode 1 = Parallel operation (mid-position) 2 = Permanent heating mode position	0 = Normal operating mode	
D.071	Max. heating target flow temp.	40 ... 80 °C	75 °C	
D.072	Pump overrun after cylinder charging	Adjustable from 0-10 minutes in increments of 1 minute	2 mins	
D.073	Offset setting for comfort mode	Adjustable from -15 K to 5 K	0	
D.074	Anti-legionella funct. with integrated cyl.	0 = Off 1 = On	1 = On	
D.075	Max. cylinder charging time	20 - 90 min	45 mins	
D.076	Device Specific Number	Device specific number = DSN 1 = 612 (VU GB 126/5-5), VU 126/5-5 (H-GB) ecoTEC plus 612 3 = 615 (VU GB 156/5-5), VU 156/5-5 (H-GB) ecoTEC plus 615 4 = 618 (VU GB 186/5-5), VU 186/5-5 (H-GB) ecoTEC plus 618, VU 186/5-5 (P-GB) ecoTEC plus 618 9 = 624 (VU GB 246/5-5), VU 246/5-5 (H-GB) ecoTEC plus 624 14 = 630 (VU GB 306/5-5), VU 306/5-5 (H-GB) ecoTEC plus 630, VU 306/5-5 (P-GB) ecoTEC plus 630 20 = 637 (VU GB 376/5-5); VU GB 386/5-5, VU 386/5-5 (H-GB) ecoTEC plus 637 6 = 825 (VUW GB 256/5-5); VUW GB 196/5-5, VUW 196/5-5 (H-GB) ecoTEC plus 825 10 = 832 (VUW GB 326/5-5); VUW GB 246/5-5, VUW 246/5-5 (H-GB) ecoTEC plus 832, VUW 246/5-5 (P-GB) ecoTEC plus 832 13 = 835 (VUW GB 356/5-5); VUW GB 306/5-5, VUW 306/5-5 (H-GB) ecoTEC plus 835 17 = 838 (VUW GB 386/5-5); VUW GB 286/5-5; VUW 286/5-5 (H-GB) ecoTEC plus 838, 938 (VUI GB 386/5-5 A), VUI 286/5-5 (H-GB) ecoTEC plus 938		Not adjustable
D.077	DHW partial load	Adjustable cylinder charging output in kW		
D.078	DHW max. flow temperature	Limit on cylinder charging temperature in °C 50 °C – 80 °C <b>Note</b> The chosen value must be at least 15 K or 15 °C above the set cylinder target value.		75 °C
D.080	Heating operating hours	In hours (h)		Not adjustable
D.081	DHW operating hours	In hours (h)		Not adjustable
D.082	Heating burner starts	Number of burner start-ups		Not adjustable
D.083	DHW burner starts	Number of burner start-ups		Not adjustable
D.084	Maintenance in	Adjustment range: 0 to 3000 hrs and "---" for deactivated	„---“	

Code	Parameter	Values or explanations	Default setting	Own setting
D.088	Min. DHW flow rate	Start delay for hot water draw-off detection via impeller (only products with integrated hot water generation) 0 = 1.5 l/min and no delay, 1 = 3.7 l/min and 2 sec. delay	1.5 l/min and no delay	
D.090	eBUS controller	Status of digital controller Recognised, not recognised		Not adjustable
D.091	Status DCF77	Status of DCF with external temperature sensor connected No reception Reception Synchronised Valid		Not adjustable
D.092	actoSTOR communication status	actoSTOR module detection 0 = Not connected 1 = Connection error: No communication via PeBus, actoSTOR module was previously detected 2 = Connection active		Not adjustable
D.093	Adjust Device Specific Number	Device Specific Number (DSN) Setting range: 0 to 99		
D.094	Clear fault history	Delete fault list 0 = No 1 = Yes		
D.095	Software version: PeBUS participant	PCB (BMU) Display (AI) actoSTOR (APC) HBI/VR34		Not adjustable
D.096	Reset to factory settings?	Reset all adjustable parameters to factory setting 0 = No 1 = Yes		
D.098	Coding resistor	Display xx.yy xx = Coding resistance 1 in cable harness for output range: 8 = 612 (VU GB 126/5-5 A); VU GB 126/5-5; VU 126/5-5 (H-GB) ecoTEC plus 612, 615 (VU GB 156/5-5 A); VU GB 156/5-5; VU 156/5-5 (H-GB) ecoTEC plus 615; 618 (VU GB 186/5-5 A); VU GB 186/5-5; VU 186/5-5 (H-GB) ecoTEC plus 618, VU 186/5-5 (P-GB) ecoTEC plus 618; 825 (VUW GB 256/5-5); VUW GB 196/5-5; VUW 196/5-5 (H-GB) ecoTEC plus 825 9 = 624 (VU GB 246/5-5 A); VU GB 246/5-5; VU 246/5-5 (H-GB) ecoTEC plus 624; 832 (VUW GB 326/5-5); VUW GB 326/5-5; VUW 246/5-5 (H-GB) ecoTEC plus 832; VUW 246/5-5 (P-GB) ecoTEC plus 832 10 = 630 (VU GB 306/5-5 A); VU GB 306/5-5; VU 306/5-5 (H-GB) ecoTEC plus 630; VU 306/5-5 (P-GB) ecoTEC plus 630; 835 (VUW GB 356/5-5); VUW GB 306/5-5; VUW 306/5-5 (H-GB) ecoTEC plus 835 11 = 637 (VU GB 376/5-5 A); VU GB 386/5-5; VU 386/5-5 (H-GB) ecoTEC plus 637; 838 (VUW GB 386/5-5); VUW GB 286/5-5; VUW 286/5-5 (H-GB) ecoTEC plus 838; 938 (VUI GB 386/5-5 A); VUI 286/5-5 (H-GB) ecoTEC plus 938 yy = Coding resistance 2 on PCB for gas group: 02 = P gas 03 = H gas 07 = L gas		Not adjustable

## Appendix

### C Status codes – Overview



#### Note

Since the code table is used for various products, some codes may not be visible for the product in question.

Statuscode	Meaning
<b>S.00 Heating: No heat demand</b>	Heating has no heat demand. The burner is off.
<b>S.01 Heating mode: Fan start-up</b>	The fan start-up for heating mode is activated.
<b>S.02 Heating mode: Pump pre-run</b>	The pump prerun for heating mode is activated.
<b>S.03 Heating mode: Ignition</b>	The ignition for heating mode is activated.
<b>S.04 Heating mode: Burner on</b>	The burner for heating mode is activated.
<b>S.05 Heating mode: Pump/fan overrun</b>	The pump/fan overrun for heating mode is activated.
<b>S.06 Heating mode: Fan overrun</b>	The fan overrun for heating mode is activated.
<b>S.07 Heating mode: Pump overrun</b>	The pump overrun for heating mode is activated.
<b>S.08 Heating mode: Anti-cycling time</b>	The anti-cycling time for heating mode is activated.
<b>S.10 DHW demand</b>	The domestic hot water demand is activated.
<b>S.11 DHW mode: Fan start-up</b>	The fan start-up for domestic hot water mode is activated.
<b>S.13 DHW mode: Ignition</b>	The ignition for domestic hot water mode is activated.
<b>S.14 DHW mode: Burner on</b>	The burner for domestic hot water mode is activated.
<b>S.15 DHW mode: Pump/fan overrun</b>	The pump/fan overrun for domestic hot water mode is activated.
<b>S.16 DHW mode: Fan overrun</b>	The fan overrun for domestic hot water mode is activated.
<b>S.17 DHW mode: Pump overrun</b>	The pump overrun for domestic hot water mode is activated.
<b>S.20 DHW demand</b>	The domestic hot water demand is activated.
<b>S.21 DHW mode: Fan start-up</b>	The fan start-up for domestic hot water mode is activated.
<b>S.22 DHW mode: Pump pre-run</b>	The pump prerun for domestic hot water mode is activated.
<b>S.23 DHW mode: Ignition</b>	The ignition for domestic hot water mode is activated.
<b>S.24 DHW mode: Burner on</b>	The burner for domestic hot water mode is activated.
<b>S.25 DHW mode: Pump/fan overrun</b>	The pump/fan overrun for domestic hot water mode is activated.
<b>S.26 DHW mode: Fan overrun</b>	The fan overrun for domestic hot water mode is activated.
<b>S.27 DHW mode: Pump overrun</b>	The pump overrun for domestic hot water mode is activated.
<b>S.28 DHW anti-cycling time</b>	The anti-cycling time for domestic hot water mode is activated.
<b>S.30 No heat demand: Controller</b>	Room thermostat blocks heating mode.
<b>S.31 No heat demand: Summer mode</b>	Summer mode is activated; there is no heat demand.
<b>S.32 Waiting time deviation: Fan speed</b>	The waiting period for the fan start-up is activated.
<b>S.34 Heating mode: Frost protection</b>	The frost protection function for heating mode is activated.
<b>S.39 Contact thermostat triggered</b>	The surface-mounted thermostat or the condensate pump has triggered.
<b>S.40 Comfort protection active</b>	The comfort protection mode is activated.
<b>S.41 Water pressure too high</b>	The system pressure is too high.

Statuscode	Meaning
<b>S.42 Flue non-return flap closed</b>	Flue non-return flap return signal blocks burner operation (only in conjunction with the multi-functional module) or condensate pump defective, heat demand is blocked.
<b>S.46 Comfort protection: Minimum load, loss of flame</b>	Comfort protection mode for flame loss at minimum load is activated.
<b>S.53 Waiting time: Water shortage</b>	The product is within the waiting period of the modulation block/operating block function as a result of a water deficiency (flow/return spread too large).
<b>S.54 Waiting time: Water shortage</b>	Product is in the waiting period of the operation blocking function as a result of low water pressure (temperature gradient).
<b>S.57 Waiting time: Measuring program</b>	The product is within the waiting period as a result of the measuring programme.
<b>S.58 Burner modulation limitation</b>	The burner modulation limitation is activated.
<b>S.61 Fault: Incorrect gas type</b>	The coding resistor on the PCB does not match the entered gas group (see also F.92).
<b>S.62 Adjust CO2</b>	Set the CO <sub>2</sub> content.
<b>S.63 Fault: Check gas route</b>	A fault message is activated. Check the gas route.
<b>S.76 Service message: Check water pressure</b>	A service message is activated. Check the water pressure.
<b>S.88 Purging programme is running</b>	The purge programme is activated.
<b>S.92 Water circulation volume self-test</b>	The self-test for the water circulation volume is activated.
<b>S.93 Flue gas measurement not possible</b>	Flue gas analysis is not currently possible.
<b>S.96 Return temperature sensor self-test</b>	The self-test for the return temperature sensor is activated.
<b>S.97 Water pressure sensor self-test</b>	The self-test for the water pressure sensor is activated.
<b>S.98 Flow/return temperature sensor self-test</b>	The self-test for the flow/return temperature sensor is activated.
<b>S.99 Vaillant self-test</b>	The Vaillant self-test is activated.

## D Overview of fault codes



### Note

Since the code table is used for various products, some codes may not be visible for the product in question.

Message	Possible cause	Measure
<b>F.00 Interruption: Flow sensor</b>	Flow temperature sensor defective or not connected	► Check: Flow temperature sensor, plug, cable harness, PCB.
<b>F.01 Interruption: Return sensor</b>	Return temperature sensor defective or not connected	► Check: Return temperature sensor, plug, cable harness, PCB.
<b>F.02 Interruption: DHW outlet sensor</b>	Cylinder temperature sensor for the shift-load cylinder defective or not connected	► On the shift-load cylinder, check (only in conjunction with F.91): Plug, cable harness, temperature sensor.
<b>F.03 Interruption: Cylinder sensor</b>	Temperature sensor for the shift-load cylinder defective or not connected	► On the shift-load cylinder, check (only in conjunction with F.91): Temperature sensor plug, temperature sensor, PCB plug, cable harness.
<b>F.10 Short circuit: Flow sensor</b>	Flow temperature sensor defective or has short-circuited	► Check: NTC plug, cable harness, cable/housing, PCB, NTC sensor.
<b>F.11 Short circuit: Return sensor</b>	Return temperature sensor defective or has short-circuited	► Check: NTC plug, cable harness, housing, PCB, NTC sensor.
<b>F.12 Short circuit: DHW outlet sensor</b>	Cylinder temperature sensor defective or has short-circuited	► Check (only in conjunction with F.91): NTC plug, cable harness, NTC sensor, PCB.
<b>F.13 Short circuit: Cylinder sensor</b>	Warm start sensor/cylinder temperature sensor defective or not connected	<ol style="list-style-type: none"> <li>1. Check: NTC plug, earth connection, cable harness, NTC sensor, PCB.</li> <li>2. Check the following on the shift-load cylinder (in conjunction with F.91): NTC plug, earth connection, cable harness, NTC sensor, connection to the PCB.</li> </ol>

## Appendix

Message	Possible cause	Measure
<b>F.20 Safety switch-off: Temperature limiter</b>	Maximum temperature at the flow/return temperature sensor is too high when the safety cut-out function is operating using the NTC	▶ Check: Flow temperature sensor (correct thermal connection), cable harness, sufficient purging.
<b>F.22 Safety switch-off: Low water pressure</b>	No/insufficient water in the product or the water pressure is too low	1. Check: Plug, cable to heating pump or water pressure sensor, water pressure sensor, heating pump. 2. Activate and purge check programme P.0.
<b>F.23 Safety switch-off: Temp.spread too large</b>	Temperature spread too great. Water circulation too low	▶ Check: Plug, cable to heating pump/water pressure sensor, air/insufficient water in the heating circuit, flow and return temperature sensor inverted, strainer in the hydraulic block, water pressure sensor, heating pump (sufficient circulation, level 2: D.19, D.14, non-return valve). Activate check programme P.0.
<b>F.24 Safety switch-off: Temp. incr. too fast</b>	Temperature increase too fast	▶ Check: Plug, cable to the heating pump, air/insufficient water in the heating circuit, internal air vent (function), heating pump (system pressure too low, temperature gradient too great on heating flow, non-return valve). Activate check programme P.0.
<b>F.25 Safety switch-off: Flue temp. too high</b>	flue gas temperature too high	▶ Check: Plug, safety cut-out plug, cable harness, cable to the heating pump, internal air vent (function), flue gas route (blockage, adverse wind conditions, flue pipework too long), insufficient water in heating circuit, heating pump, activate check programme P.0.
<b>F.26 Fault: Fuel valve not working</b>	Gas valve assembly stepper motor defective or not connected	▶ Check: Gas valve assembly stepper motor (plug, cable, passage for rinsing, voltage), multiple plug, cable harness.
<b>F.27 Safety switch-off: Flame simulation</b>	Monitoring electrode reports an incorrect flame	▶ Check: Gas pressure at upper test opening, monitoring electrode, PCB, gas solenoid valve.
<b>F.28 Start-up failure: Ignit. unsuccessful</b>	Failure during start-up or ignition unsuccessful. Gas pressure monitor or thermal cut-out has been triggered.	▶ Check: Gas stopcock, gas flow pressure, gas valve assembly, air intake pipe (blockage, loosened screw), condensate route (blockage), multiple plug, cable harness, ignition transformer, ignition cable, ignition plug, ignition electrode, monitoring electrode, electronics, earthing, CO <sub>2</sub> setting.
<b>F.29 Operating failure: Ignit. unsuccessful</b>	Gas supply interrupted intermittently. Re-ignition failed.	▶ Check: Flue gas recirculation, condensate route (blockage), earthing, cable to the gas valve assembly and electrode (loose connection).
<b>F.32 Fault: Fan</b>	Fan defective or not connected	▶ Check: Plug, cable harness, fan (blockage, function, correct speed), Hall sensor, PCB, flue gas route (blockage).
<b>F.42 Fault: Coding resistor</b>	Coding resistor or gas group resistor causes a short circuit	▶ Check: Plug, earth connection, cable, output coding resistor (in the cable harness).
<b>F.49 Fault: eBUS</b>	Undervoltage on the eBUS	▶ Check: eBUS (overload, two power supplies with different polarities, short circuit).
<b>F.52 Mass flow sensor not connected</b>	Mass flow sensor defective or not connected	▶ Check: Plug, cable harness, mass flow sensor.
<b>F.53 Fault: Mass flow sensor</b>	Mass flow sensor defective	▶ Check: Filter below Venturi filter cap wet or blocked, gas flow pressure too low, internal pressure measuring point in the Venturi is blocked (do not use any lubricants on the O-ring in the Venturi).
<b>F.54 Fault: Boiler start</b>	No gas inlet pressure or insufficient gas inlet pressure causes faults when the product is started	▶ Check (in conjunction with F.28/F.29): Gas stopcock, gas valve assembly, plug, cable harness.
<b>F.55 Fault: CO sensor</b>	All-gas sensor defective or has short-circuited	▶ Check: Plug, cable harness, all-gas sensor, PCB.
<b>F.56 Safety switch-off: CO limit exceeded</b>	Safety shutdown after the CO limit value is exceeded	▶ Check: Gas valve assembly, plug, cable harness. If the fault occurs again after being cleared, the gas valve assembly is defective.
<b>F.57 Fault: Measuring program</b>	Regulation fault caused by corroded ignition electrode	▶ Check: Ignition electrode, PCB (microcontrol).
<b>F.61 Fault: Fuel valve actuation</b>	The gas valve assembly cannot be actuated	▶ Check: Cable harness, plug, gas valve assembly (rinse), PCB.
<b>F.62 Fault: Fuel valve switch-off delay</b>	Delayed switch-off sequence for the gas valve after the flame is extinguished	▶ Check: Gas valve, surface of the burner (dirt), plug, cable harness, PCB.
<b>F.63 Fault: EEPROM</b>	EEPROM faulty	▶ Replace: PCB.





Message	Possible cause	Measure
<b>F.64 Fault: Electronics/sensor</b>	Electronics, safety-relevant sensor or cable defective	► Check: Flow sensor, cable to the sensor, flame recording sensor (e.g. ionisation electrode) for an unstable signal, electronics.
<b>F.65 Fault: Electronics temp.</b>	Electronics defective or too hot due to external influences	1. Check: PCB. 2. If required, reduce the environmental temperature.
<b>F.67 Fault: Electronics/flame</b>	Implausible flame signal	► Check: Cable harness, flame monitor, PCB.
<b>F.68 Fault: Flame signal unstable</b>	Flame monitor reports an unstable flame signal	► Check: Air ratio, gas flow pressure, condensate route (blockage), gas injector, ionisation flow (cable, electrode), flue gas recirculation.
<b>F.70 Fault: Invalid Device Specific Number</b>	Incorrect/missing Device Specific Number or incorrect/missing coding resistor	► If the display and PCB have been replaced, change the Device Specific Number under <b>D.93</b> .
<b>F.71 Fault: Flow sensor</b>	Flow temperature sensor returns implausible values	► Check: Flow temperature sensor (correct thermal connection).
<b>F.72 Fault: Flow/return sensor</b>	Temperature difference between flow and return temperature sensor is too great	► Check: Flow temperature sensor/return temperature sensor (function, correct thermal connection).
<b>F.73 Fault: Water press. sensor (signal too weak)</b>	Water pressure sensor reports that the water pressure is too low	► Check: Water pressure, earth connection, cable, plug, water pressure sensor (short circuit to GDN).
<b>F.74 Fault: Water press. sensor (signal too strong)</b>	Water pressure too high	► Check: Water pressure (heating side, when heating pump is not active), drain water if required, cable, water pressure sensor (short circuit to 24/5 V).
<b>F.75 Fault: Pump/ water shortage</b>	Insufficient pressure jump detected when starting the pump	1. Check: Water pressure sensor, heating pump (blockage), heating circuit (air, sufficient water volume), adjustable bypass, external expansion vessel (must be connected at the return). Activate check programme P.0. 2. If a low loss header or heating pipes with a diameter greater than 1 1/2 inch are installed, replace the 3/4-inch seal in the heating flow with a screen. If required, install the F.75 service set.
<b>F.77 Fault: Flue non-ret. valve/condens. pump</b>	No flue non-return flap feedback; condensate pump overflow	► Check: Cable to VR40 accessory, flue non-return flap (wiring, feedback switch), condensate pump, bridge from the surface-mounted thermostat, 2 in 7 multi-functional module (bridge).
<b>F.78 Interrupt.: DHW outlet sensor on ext. contr.</b>	UK link box is connected without the domestic hot water temperature sensor being bridged	1. Check: Accessory (configuration/electrical connection). 2. The unit displays a fault, but the unit has not malfunctioned.
<b>F.80 Fault: actoSTOR inlet sensor</b>	Inlet temperature sensor defective or not connected	► Check (only in conjunction with F.91): NTC sensor, plug, cable harness, PCB.
<b>F.81 Fault: cylinder charging pump</b>	Cylinder is not fully charged after specified time	► Check (only in conjunction with F.91): Cylinder charging sensor, cylinder sensor, impeller sensor/limiter, prioritising diverter valve, pump, <b>actoSTOR</b> pump (air), cable harness, secondary heat exchanger (blockage).
<b>F.82 Fault: Ext. current anode</b>	External current anode defective or not connected	► Check: Cable harness, external current anode. If the external current anode is not installed: Plug edge connector X43 with a bridge into the PCB.
<b>F.83 Fault: NTC temp. gradient</b>	Temperature difference between flow and return temperature sensor is too small	► Check: Flow/return temperature sensor (function, correct thermal connection), sufficient water volume.
<b>F.84 Fault: NTC temp. diff. implausible</b>	Temperature difference is implausible	► Check: Flow/return temperature sensor (correct thermal connection, sensors are inverted).
<b>F.85 Fault: NTCs fitted incorrectly</b>	Flow/return temperature sensors returning incorrect/implausible values	► Check: Flow/return temperature sensor (correct thermal connection).
<b>F.90 Fault: Communication</b>	Communication with actoSTOR interrupted	1. Check: Plug, check cable harness to the <b>actoSTOR</b> module (PEBus). 2. If the product is to be operated without an <b>actoSTOR</b> : Set D.092=0, if required, plug edge connector X31 into the BMU, if required plug edge connector X1 into the actoSTOR.
<b>F.91 Fault: actoSTOR sensor</b>	Sensor on the actoSTOR is defective	► Check: Plug, cable harness, sensor.

## Appendix

Message	Possible cause	Measure
<b>F.92 Fault: Incorrect gas type</b>	The coding resistor on the PCB does not match the gas group that is entered	<ol style="list-style-type: none"> <li>1. Check: Coding resistor.</li> <li>2. Carry out the gas family check again and enter the correct gas group.</li> </ol>
<b>F.93 Fault: Check gas route</b>	Combustion quality outside the permitted range	▶ Check: Gas injector (suitable for the gas group), flue gas recirculation, gas group, internal pressure measuring point in the Venturi (blockage). Do not use any lubricants on the O-ring in the Venturi.
<b>F.94 Fault: Vortex and differential pressure</b>	Sensors return implausible values.	▶ Check: Cable harness, plug, sensors.
<b>LED actoSTOR Modul</b> actoSTOR communication status	actoSTOR communication status: Not connected, Connection error, Connection active	<ol style="list-style-type: none"> <li>1. LED on: Communication OK.</li> <li>2. LED flashing: Communication not OK.</li> <li>3. LED off: No power supply.</li> </ol>
<b>Communication fault</b>	Communication fault between the display and the PCB in the electronics box	▶ Check: Cable/plug between the display and the PCB.

## E Check programmes – Overview

Prüfprogramme	Meaning
<b>P.00 Purging</b>	The internal pump is cyclically actuated. The heating circuit and the domestic hot water circuit are adaptively purged by automatically switching the circuits using the automatic air vent (the automatic air vent's flap must be loose). The active circuit is shown in the display. Press  once to start purging the heating circuit. Press  once to end the purge programme. Note: The purge programme runs for 7.5 min per circuit and then terminates. Purging the heating circuit: Prioritising diverter valve in heating position, actuation of internal pump for 9 cycles: 30 seconds on, 20 seconds off. Display: Active heating circuit. Purging the domestic hot water circuit: After the above-mentioned cycles have run or the right-hand selection button has been pressed again: Prioritising diverter valve in the domestic hot water position, actuation of the internal pump as above. Display: Active hot water circuit.
<b>P.01 Maximum load</b>	After successful ignition, the product is operated at maximum heat input.
<b>P.02 Minimum load</b>	After successful ignition, the product is operated at minimum heat input.
<b>P.06 Filling mode</b>	The prioritising diverter valve is moved to the mid-position. The burner and pump are switched off (to fill or drain the product).

## F Function menu – Overview

Function menu	Meaning
<b>T.01 Internal pump</b>	The internal pump is switched on and off.
<b>T.02 3-way valve</b>	The prioritising diverter valve is moved to the heating or domestic hot water position.
<b>T.03 Fan</b>	The fan is switched on and off. The fan runs at maximum rotational speed.
<b>T.04 Cylinder charging pump</b>	The cylinder charging pump is switched on and off.
<b>T.05 Circulation pump</b>	The circulation pump is switched on and off.
<b>T.06 External pump</b>	The external pump is switched on and off.
<b>T.08 Burner</b>	The product starts up and switches to minimum load. The flow temperature is shown in the display.



## Appendix

3	Gas valve assembly	13	Bus connection (digital room thermostat/control)
4	Mass flow sensor	14	Prioritising diverter valve
5	Outdoor temperature sensor, flow temperature sensor (optional, external), DCF receiver	15	Water pressure sensor
6	Circulation pump remote control	16	Cylinder temperature sensor
7	Power coding resistor	17	Cylinder contact "C1/C2"
8	Return temperature sensor	18	Gas group coding resistor
9	Flow temperature sensor	19	Additional relay (select via D.026)
10	Fan	20	Internal pump
11	Surface-mounted thermostat/burner off	21	Ignition electrode
12	24 V DC room thermostat	*	Depending on product type

G.2 Connection diagram, product for heating mode only, ≥ 37 kW

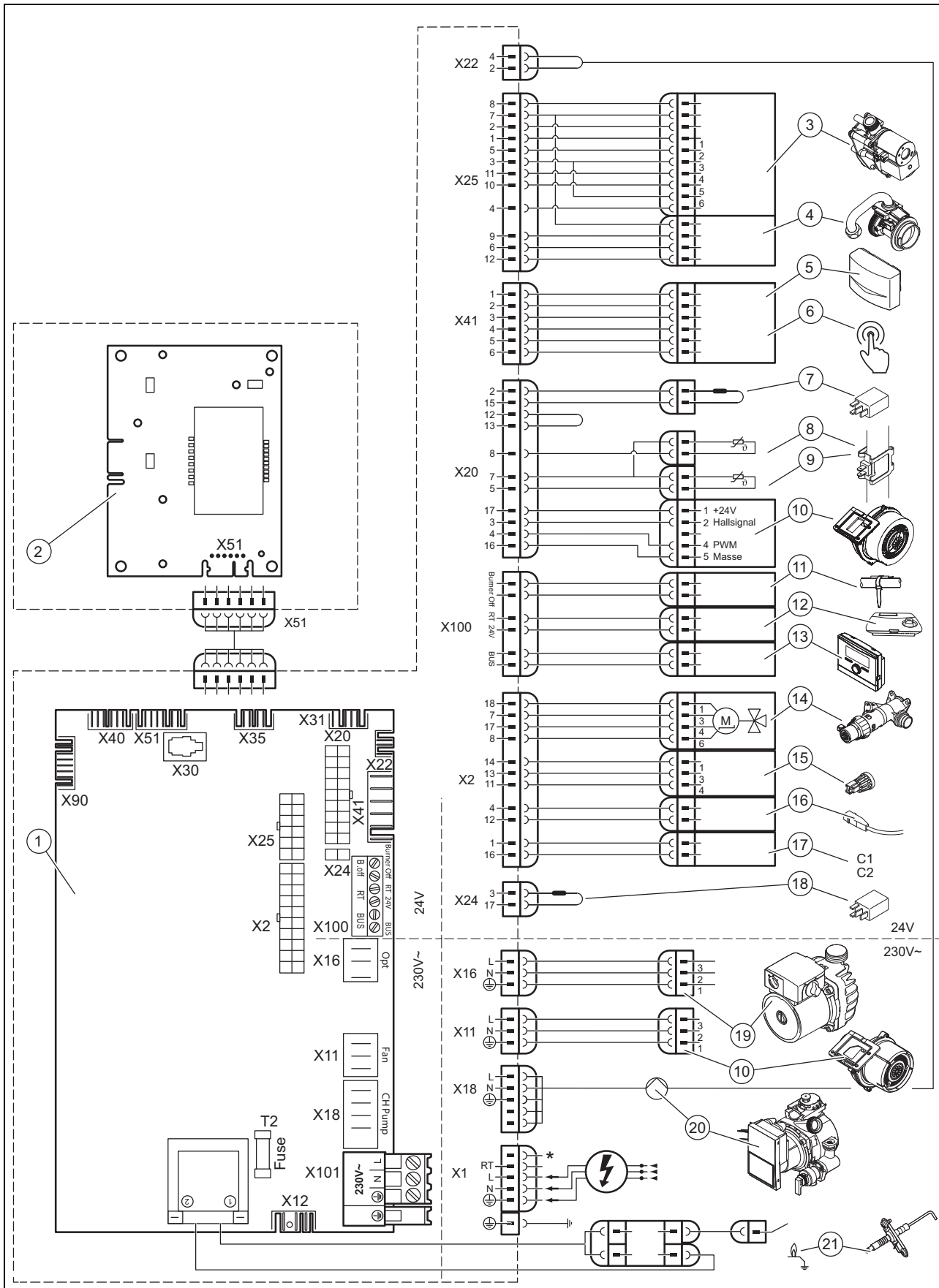

- |   |                            |   |  |
|---|----------------------------|---|--|
| 1 | Main PCB                   | 4 | Mass flow sensor   |
| 2 | Operator control panel PCB | 5 | Outside temperature sensor, flow temperature sensor (optional, external), DCF receiver |
| 3 | Gas valve                  |   |  |

## Appendix

6	Circulation pump remote control	15	Water pressure sensor
7	Power coding resistor	16	Cylinder temperature sensor
8	Return temperature sensor	17	Cylinder contact "C1/C2"
9	Flow temperature sensor	18	Gas group coding resistor
10	Fan	19	Auxiliary relay (select via D.026)
11	Contact thermostat/burner off	20	Internal pump
12	24 V DC room thermostat	21	Ignition electrode
13	Bus connection (digital room thermostat/controller)	*	Depending on product type
14	Diverter valve		



G.3 Connection diagram, product with integrated hot water generation, 12 - 35 kW

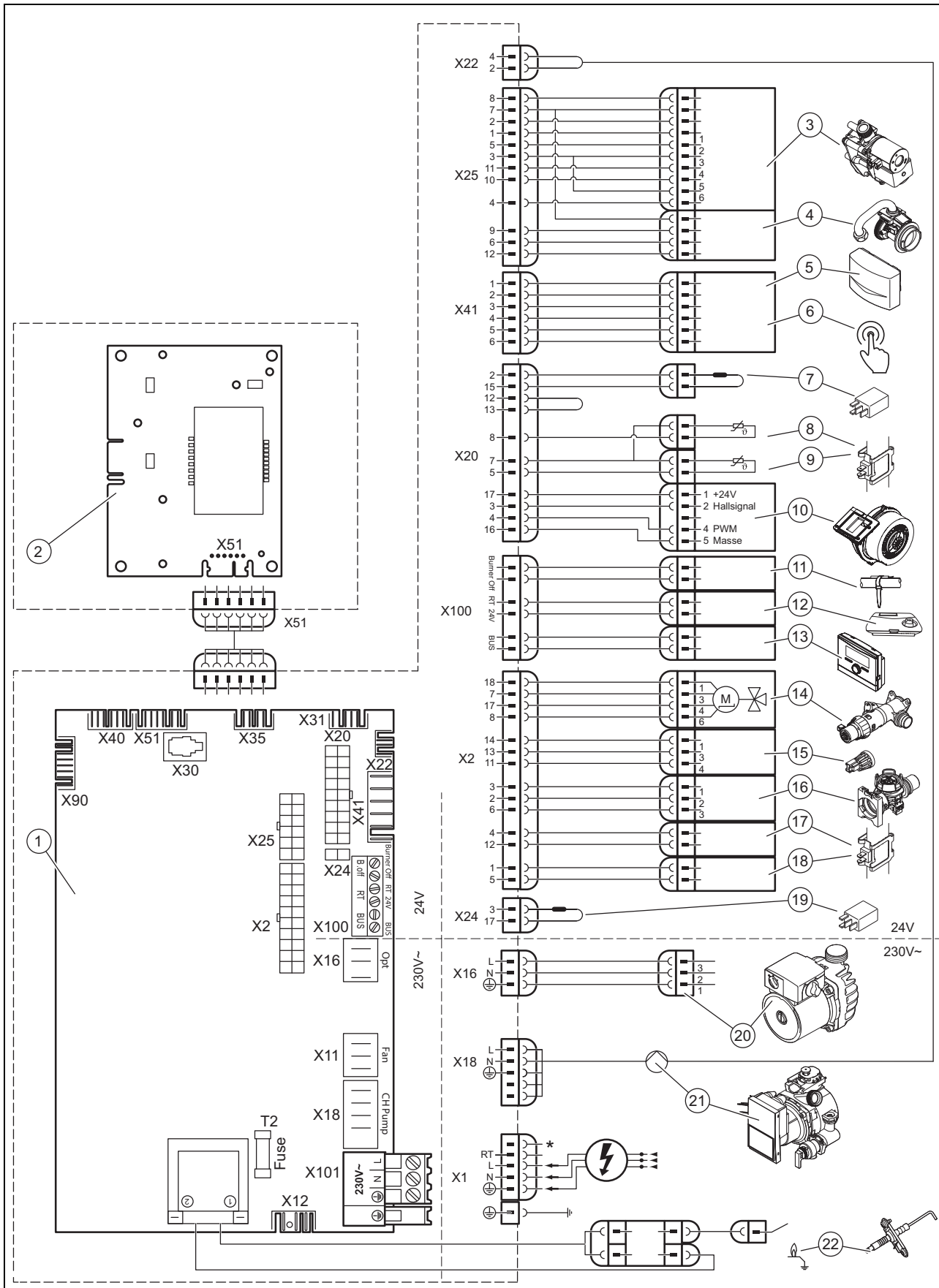

- |   |                            |   |  |
|---|----------------------------|---|--|
| 1 | Main PCB                   | 4 | Mass flow sensor   |
| 2 | Operator control panel PCB | 5 | Outside temperature sensor, flow temperature sensor (optional, external), DCF receiver |
| 3 | Gas valve                  |   |  |

## Appendix

6	Circulation pump remote control	15	Water pressure sensor
7	Power coding resistor	16	Impeller sensor
8	Return temperature sensor	17	Warm start sensor
9	Flow temperature sensor	18	Hot water sensor
10	Fan	19	Gas group coding resistor
11	Contact thermostat/burner off	20	Auxiliary relay (select via D.026)
12	24 V DC room thermostat	21	Internal pump
13	Bus connection (digital room thermostat/controller)	22	Ignition electrode
14	Diverter valve	*	Depending on product type

G.4 Wiring diagram, product with integrated domestic hot water generation, ≥ 37 kW

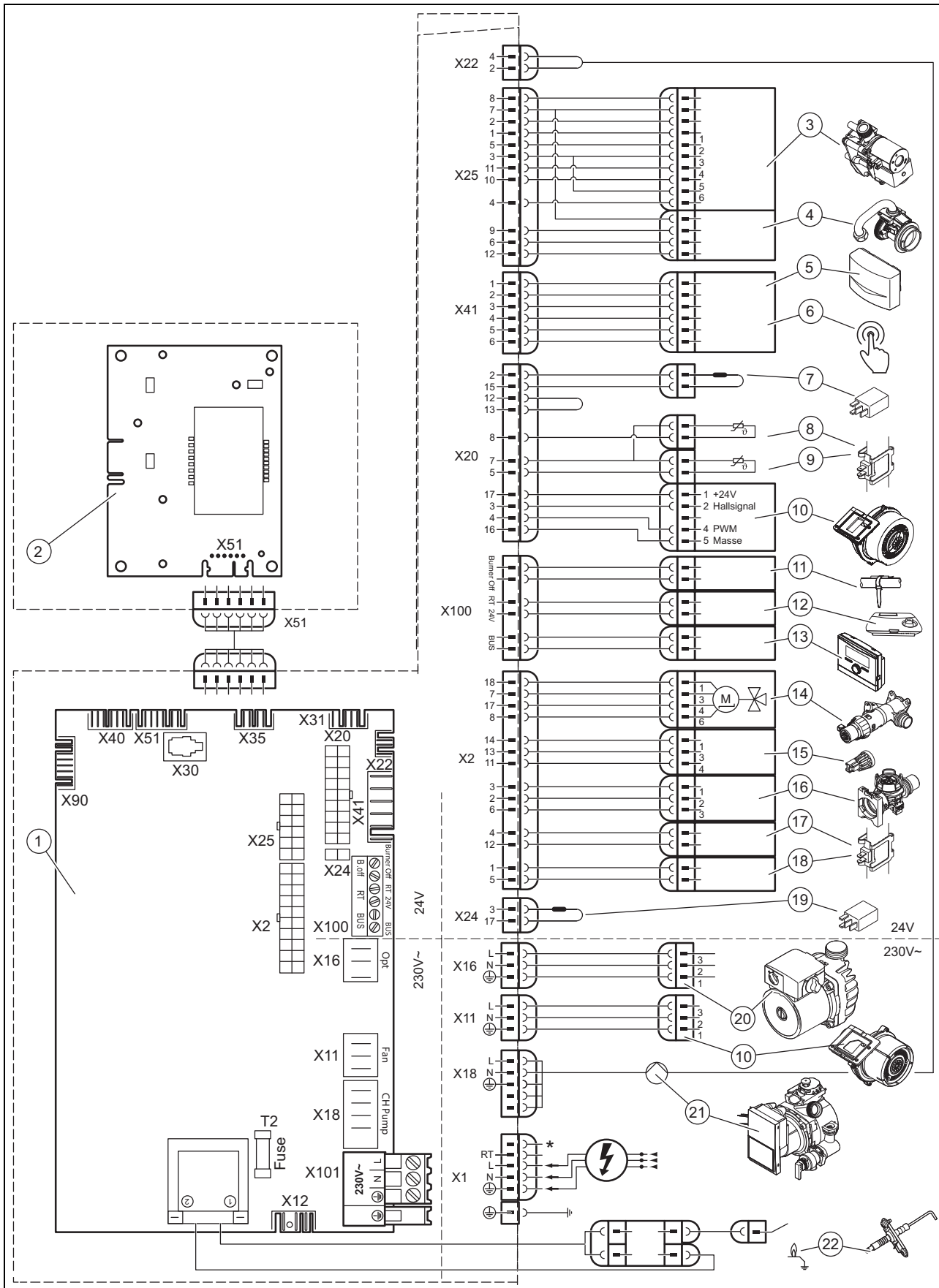

- 1 Main PCB
- 2 Control panel PCB
- 3 Gas valve assembly

- 4 Mass flow sensor
- 5 Outdoor temperature sensor, flow temperature sensor (optional, external), DCF receiver

## Appendix

6	Circulation pump remote control	15	Water pressure sensor
7	Power coding resistor	16	Impeller sensor
8	Return temperature sensor	17	Warm start sensor
9	Flow temperature sensor	18	Domestic hot water sensor
10	Fan	19	Gas group coding resistor
11	Surface-mounted thermostat/burner off	20	Additional relay (select via D.026)
12	24 V DC room thermostat	21	Internal pump
13	Bus connection (digital room thermostat/control)	22	Ignition electrode
14	Prioritising diverter valve	*	Depending on product type

## H Inspection and maintenance work

The table below lists the manufacturer requirements with respect to minimum inspection and maintenance intervals. If national regulations and directives require shorter inspection and maintenance intervals, you should observe these instead of the intervals listed. Each time inspection and maintenance work is carried out, carry out the required preparatory and completion work.

#	Maintenance work	Interval	
1	Check the tightness of the air/flue pipe, make sure that it is not damaged and has been attached correctly, and check that it has been set up correctly	Annually	
2	Removing dirt from the product and the vacuum chamber	Annually	
3	Visually check the heat cell to ascertain its condition and detect any corrosion, rust or damage, and carry out maintenance work, if required	Annually	
4	Checking the gas connection pressure at maximum heat input	Annually	
5	Checking the CO <sub>2</sub> content and, if necessary, adjusting it (air index setting)	Annually	24
6	Recording the CO <sub>2</sub> content (the air ratio)	Annually	
7	Check that the connections/electrical plug connections have been connected correctly/function correctly (product must be voltage-free)	Annually	
8	Check that the gas stopcock and service valves function correctly	Annually	
9	Checking the condensate trap for dirt and cleaning it	Annually	
10	Checking the pre-charge pressure of the expansion vessel	If required, at least every 2 years	
11	Checking the pre-charge pressure in the shift-load cylinder expansion vessel	Annually	
12	Checking the insulating mats in the combustion area and replacing damaged insulating mats	If required, at least every 2 years	
13	Cleaning the heat exchanger	If required, at least every 2 years	34
14	Check the burner for damage	If required, at least every 2 years	
15	If the water volume is insufficient (domestic hot water) or the outlet temperature is insufficient, check the secondary heat exchanger	If required, at least every 2 years	
16	Cleaning the filter in the cold water inlet	If required, at least every 2 years	35
17	Check the impeller sensor for dirt/damage	If required, at least every 2 years	
18	Filling the heating installation	If required, at least every 2 years	21
19	Run the test operation on the product/heating installation including domestic hot water generation (if available) and, if required, purge the product/heating installation	Annually	
20	Perform the gas family check	If required, at least every 2 years	
21	Visually check the ignition and burner behaviour	Annually	
22	Re-checking the CO <sub>2</sub> content (the air ratio)	If required, at least every 2 years	
23	Check the product for gas, flue gas and water leaks	Annually	
24	Completing inspection and maintenance work	Annually	36

## I Commissioning Checklist

### Benchmark Commissioning and Servicing Section

It is a requirement that the boiler is installed and commissioned to the manufacturers instructions and the data fields on the commissioning checklist completed in full.

To instigate the boiler guarantee the boiler needs to be registered with the manufacturer within one month of the installation.

To maintain the boiler guarantee it is essential that the boiler is serviced annually by a Gas Safe registered engineer who has been trained on the boiler installed. The service details should be recorded on the Benchmark Service Interval Record and left with the householder.



[www.centralheating.co.uk](http://www.centralheating.co.uk)

# Appendix

## GAS BOILER SYSTEM COMMISSIONING CHECKLIST

This Commissioning Checklist is to be completed in full by the competent person who commissioned the boiler as a means of demonstrating compliance with the appropriate Building Regulations and then handed to the customer to keep for future reference.

Failure to install and commission according to the manufacturer's instructions and complete this Benchmark Commissioning Checklist will invalidate the warranty. This does not affect the customer's statutory rights.

Customer name:				Telephone number:				
Address:								
Boiler make and model:								
Boiler serial number:								
Commissioned by (PRINT NAME):				Gas Safe register number:				
Company name:				Telephone number:				
Company address:								
Commissioning date:								
<b>To be completed by the customer on receipt of a Building Regulations Compliance Certificate*</b>								
Building Regulations Notification Number (if applicable):								
<b>CONTROLS</b> (tick the appropriate boxes)								
Time and temperature control to heating	Room thermostat and programmer/timer			Programmable room thermostat				
	Load/weather compensation			Optimum start control				
Time and temperature control to hot water	Cylinder thermostat and programmer/timer			Combination Boiler				
Heating zone valves	Fitted			Not required				
Hot water zone valves	Fitted			Not required				
Thermostatic radiator valves	Fitted			Not required				
Automatic bypass to system	Fitted			Not required				
Boiler interlock				Provided				
<b>ALL SYSTEMS</b>								
The system has been flushed and cleaned in accordance with BS7593 and boiler manufacturer's instructions							Yes	
What system cleaner was used?								
What inhibitor was used?							Quantity	litres
Has a primary water system filter been installed?							Yes	No
<b>CENTRAL HEATING MODE</b> measure and record:								
Gas rate	m <sup>3</sup> /hr		<b>OR</b>		ft <sup>3</sup> /hr			
Burner operating pressure (if applicable)	mbar		<b>OR</b>	Gas inlet pressure	mbar			
Central heating flow temperature					°C			
Central heating return temperature					°C			
<b>COMBINATION BOILERS ONLY</b>								
Is the installation in a hard water area (above 200ppm)?							Yes	No
If yes, and if required by the manufacturer, has a water scale reducer been fitted?							Yes	No
What type of scale reducer has been fitted?								
<b>DOMESTIC HOT WATER MODE</b> Measure and Record:								
Gas rate	m <sup>3</sup> /hr		<b>OR</b>		ft <sup>3</sup> /hr			
Burner operating pressure (at maximum rate)	mbar		<b>OR</b>	Gas inlet pressure at maximum rate	mbar			
Cold water inlet temperature					°C			
Hot water has been checked at all outlets							Yes	Temperature °C
Water flow rate					l/min			
<b>CONDENSING BOILERS ONLY</b>								
The condensate drain has been installed in accordance with the manufacturer's instructions and/or BS5546/BS6798							Yes	
<b>ALL INSTALLATIONS</b>								
Record the following:	At max. rate:	CO	ppm	<b>AND</b>	CO/CO <sub>2</sub>	Ratio		
	At min. rate: (where possible)	CO	ppm	<b>AND</b>	CO/CO <sub>2</sub>	Ratio		
The heating and hot water system complies with the appropriate Building Regulations							Yes	
The boiler and associated products have been installed and commissioned in accordance with the manufacturer's instructions							Yes	
The operation of the boiler and system controls have been demonstrated to and understood by the customer							Yes	
The manufacturer's literature, including Benchmark Checklist and Service Record, has been explained and left with the customer							Yes	
Commissioning Engineer's Signature								
Customer's Signature								
(To confirm satisfactory demonstration and receipt of manufacturer's literature)								

\*All installations in England and Wales must be notified to Local Authority Building Control (LABC) either directly or through a Competent Persons Scheme. A Building Regulations Compliance Certificate will then be issued to the customer.





**SERVICE RECORD**

It is recommended that your heating system is serviced regularly and that the appropriate Service Interval Record is completed.

**Service Provider**

Before completing the appropriate Service Record below, please ensure you have carried out the service as described in the manufacturer's instructions. Always use the manufacturer's specified spare part when replacing controls.

<b>SERVICE 01</b>				Date:			
Engineer name:							
Company name:							
Telephone No:							
Gas safe register No:							
Record:	At max. rate:	CO	ppm	AND	CO <sub>2</sub> %		
	At min. rate: (Where Possible)	CO	ppm	AND	CO <sub>2</sub> %		
Comments:							
Signature							

<b>SERVICE 02</b>				Date:			
Engineer name:							
Company name:							
Telephone No:							
Gas safe register No:							
Record:	At max. rate:	CO	ppm	AND	CO <sub>2</sub> %		
	At min. rate: (Where Possible)	CO	ppm	AND	CO <sub>2</sub> %		
Comments:							
Signature							

<b>SERVICE 03</b>				Date:			
Engineer name:							
Company name:							
Telephone No:							
Gas safe register No:							
Record:	At max. rate:	CO	ppm	AND	CO <sub>2</sub> %		
	At min. rate: (Where Possible)	CO	ppm	AND	CO <sub>2</sub> %		
Comments:							
Signature							

<b>SERVICE 04</b>				Date:			
Engineer name:							
Company name:							
Telephone No:							
Gas safe register No:							
Record:	At max. rate:	CO	ppm	AND	CO <sub>2</sub> %		
	At min. rate: (Where Possible)	CO	ppm	AND	CO <sub>2</sub> %		
Comments:							
Signature							

<b>SERVICE 05</b>				Date:			
Engineer name:							
Company name:							
Telephone No:							
Gas safe register No:							
Record:	At max. rate:	CO	ppm	AND	CO <sub>2</sub> %		
	At min. rate: (Where Possible)	CO	ppm	AND	CO <sub>2</sub> %		
Comments:							
Signature							

<b>SERVICE 06</b>				Date:			
Engineer name:							
Company name:							
Telephone No:							
Gas safe register No:							
Record:	At max. rate:	CO	ppm	AND	CO <sub>2</sub> %		
	At min. rate: (Where Possible)	CO	ppm	AND	CO <sub>2</sub> %		
Comments:							
Signature							

<b>SERVICE 07</b>				Date:			
Engineer name:							
Company name:							
Telephone No:							
Gas safe register No:							
Record:	At max. rate:	CO	ppm	AND	CO <sub>2</sub> %		
	At min. rate: (Where Possible)	CO	ppm	AND	CO <sub>2</sub> %		
Comments:							
Signature							

<b>SERVICE 08</b>				Date:			
Engineer name:							
Company name:							
Telephone No:							
Gas safe register No:							
Record:	At max. rate:	CO	ppm	AND	CO <sub>2</sub> %		
	At min. rate: (Where Possible)	CO	ppm	AND	CO <sub>2</sub> %		
Comments:							
Signature							

<b>SERVICE 09</b>				Date:			
Engineer name:							
Company name:							
Telephone No:							
Gas safe register No:							
Record:	At max. rate:	CO	ppm	AND	CO <sub>2</sub> %		
	At min. rate: (Where Possible)	CO	ppm	AND	CO <sub>2</sub> %		
Comments:							
Signature							

<b>SERVICE 10</b>				Date:			
Engineer name:							
Company name:							
Telephone No:							
Gas safe register No:							
Record:	At max. rate:	CO	ppm	AND	CO <sub>2</sub> %		
	At min. rate: (Where Possible)	CO	ppm	AND	CO <sub>2</sub> %		
Comments:							
Signature							

\*All installations in England and Wales must be notified to Local Authority Building Control (LABC) either directly or through a Competent Persons Scheme. A Building Regulations Compliance Certificate will then be issued to the customer.



# Appendix

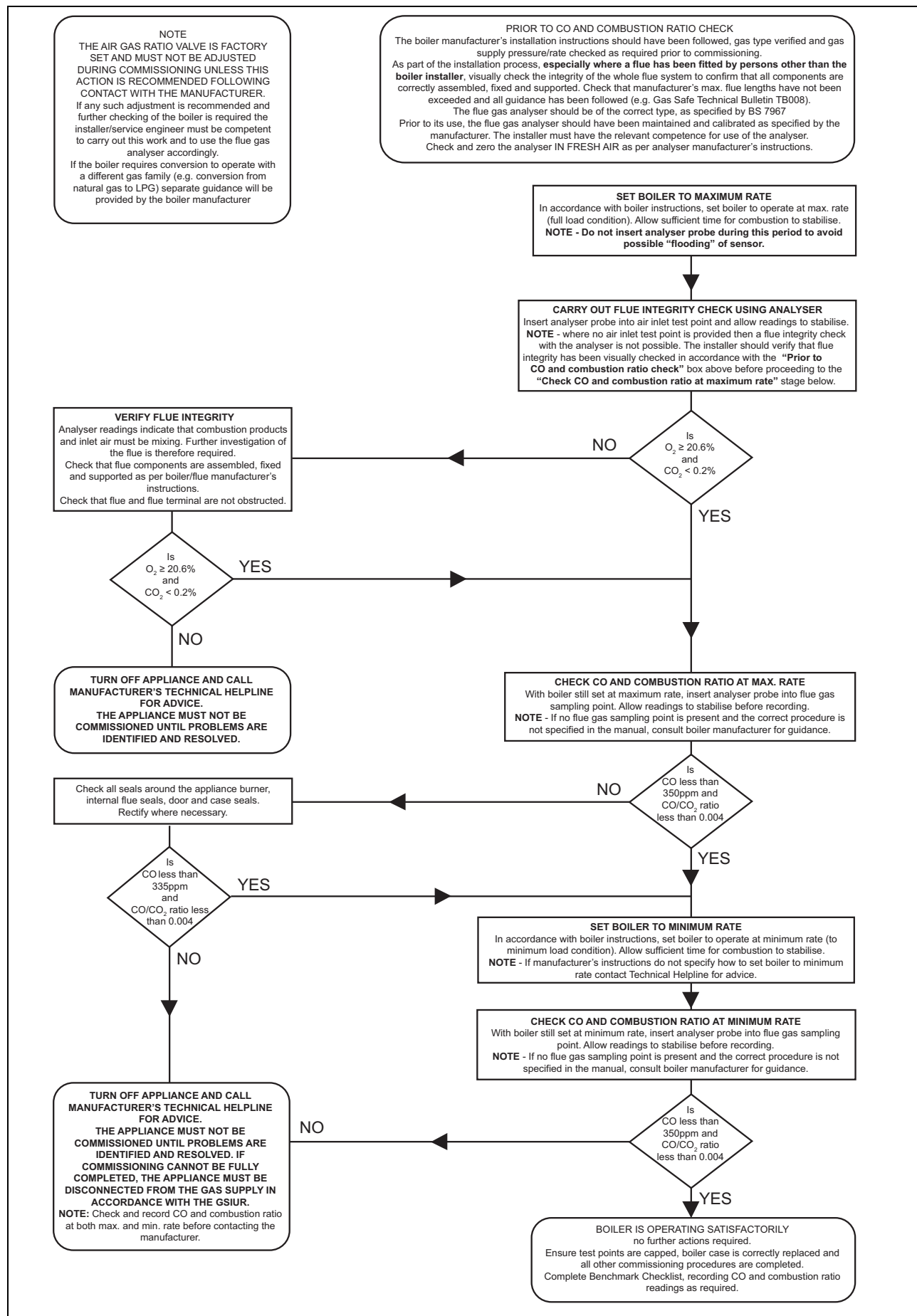

**J Opening of the flue pipe**

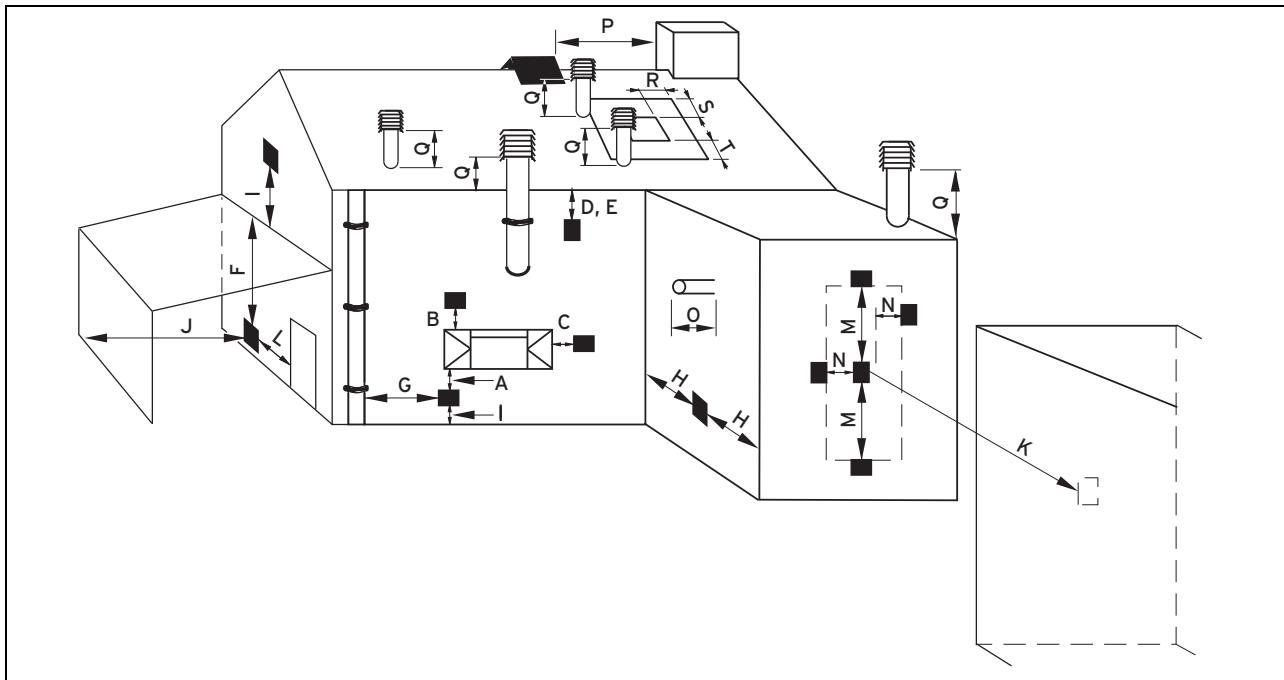

**J.1 Positioning of the opening of a fan-supported flue gas pipe**

	Installation site	Minimum dimensions
A	Directly below an opening, air bricks, opening windows, etc., that can be opened.	300 mm
B	Above an opening, air bricks, opening windows, etc., that can be opened.	300 mm
C	Horizontally to an opening, air bricks, opening windows, etc., that can be opened.	300 mm
D	Below temperature-sensitive building components, e.g. plastic gutters, down pipes or wastewater pipes	75 mm
E	Below eaves	200 mm
F	Below balconies or car port roofs	200 mm
G	From vertical wastewater pipes or down pipes	150 mm
H	From external or internal corners	200 mm
I	Above floors, roofs or balconies	300 mm
J	From a surface facing a terminal	600 mm
K	From a terminal facing a terminal	1200 mm
L	From an opening in the car port (e.g. door, window) which leads into the dwelling	1200 mm
M	Vertical from a terminal on the same wall	1500 mm
N	Horizontal from a terminal on the same wall	300 mm
O	From the wall on which the terminal has been installed	0 mm
P	From a vertical structure on the roof	N/A
Q	Above the roof area	300 mm
R	Horizontal from adjacent windows on pitched or flat roofs	600 mm
S	Above adjacent windows on pitched or flat roofs	600 mm
T	Below adjacent windows on pitched or flat roofs	2000 mm

## Appendix

### K Horizontal terminal positioning

BS 5440-1 recommends that fanned flue chimney terminals should be positioned as follows:

- at least 2 m from an opening in the building directly opposite, and
- so that the products of combustion are not directed to discharge directly across a boundary if the products are likely to cause a nuisance to a neighbour or discharge over a walkway or patio.

For IE see current issue of IS 813.

For boilers covered within this manual.

1) Dimensions D, E, F and G:

These clearances may be reduced to 25 mm without affecting the performance of the boiler. In order to ensure that the condensate plume does not affect adjacent surfaces the terminal should be extended as shown below.

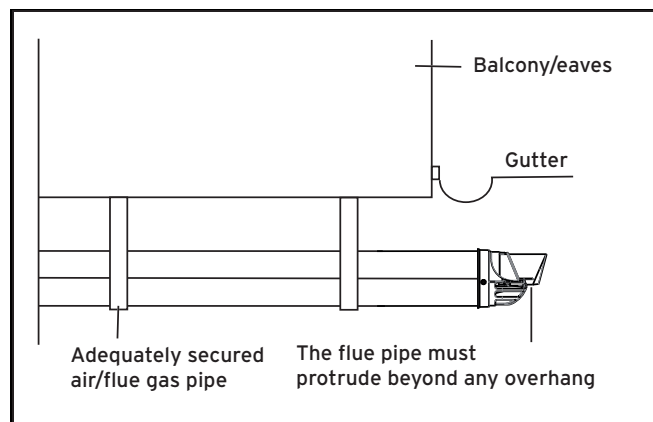

2) Dimension H:

This clearance may be reduced to 25 mm without affecting the performance of the boiler. However, in order to ensure that the condensate plume does not affect adjacent surfaces a clearance of 300 mm is preferred.

For 1 and 2 above you can use a flue gas management kit to enable the termination point to be positioned and directed away from the building fabric.

### L Technical data

#### Technical data – General

	VU 126/5-5 (H-GB) ecoTEC plus 612	VU 156/5-5 (H-GB) ecoTEC plus 615	VU 186/5-5 (H-GB) ecoTEC plus 618	VU 186/5-5 (P-GB) ecoTEC plus 618	VU 246/5-5 (H-GB) ecoTEC plus 624	VU 306/5-5 (H-GB) ecoTEC plus 630
<b>Designated country (designation in accordance with ISO 3166)</b>	GB (Great Britain), IE (Ireland)	GB (Great Britain), IE (Ireland)	GB (Great Britain), IE (Ireland)	GB (Great Britain), IE (Ireland)	GB (Great Britain), IE (Ireland)	GB (Great Britain), IE (Ireland)
<b>Approved unit categories</b>	I <sub>2H</sub>	I <sub>2H</sub>	II <sub>2H3P</sub>	II <sub>2H3P</sub>	II <sub>2H3P</sub>	II <sub>2H3P</sub>
<b>Gas connection, boiler side</b>	15 mm	15 mm	15 mm	15 mm	15 mm	15 mm
<b>Flow/return heating connections, boiler side</b>	22 mm	22 mm	22 mm	22 mm	22 mm	22 mm
<b>Hot and cold water connection, boiler side</b>						
<b>Expansion relief valve connector (min.)</b>	15 mm	15 mm	15 mm	15 mm	15 mm	15 mm
<b>Air/flue gas connection</b>	60/100 mm	60/100 mm	60/100 mm	60/100 mm	60/100 mm	60/100 mm
<b>Condensate drain pipe-work (min.)</b>	19 mm	19 mm	19 mm	19 mm	19 mm	19 mm
<b>G20 natural gas flow pressure</b>	2.0 kPa (20.0 mbar)	2.0 kPa (20.0 mbar)	2.0 kPa (20.0 mbar)		2.0 kPa (20.0 mbar)	2.0 kPa (20.0 mbar)
<b>G31 propane gas flow pressure</b>				3.7 kPa (37.0 mbar)		

	VU 126/5-5 (H-GB) ecoTEC plus 612	VU 156/5-5 (H-GB) ecoTEC plus 615	VU 186/5-5 (H-GB) ecoTEC plus 618	VU 186/5-5 (P-GB) ecoTEC plus 618	VU 246/5-5 (H-GB) ecoTEC plus 624	VU 306/5-5 (H-GB) ecoTEC plus 630
Gas flow rate at 15 °C and 1013 mbar (based on hot water generation, if applicable), G20	1.3 m³/h	1.7 m³/h	2.0 m³/h		2.6 m³/h	3.7 m³/h
Gas flow rate at 15 °C and 1013 mbar (based on hot water generation, if applicable), G31				1.5 kg/h		
Min. flue gas mass rate (G20)	1.44 g/s	1.44 g/s	1.80 g/s		2.47 g/s	2.78 g/s
Min. flue gas mass rate (G31)				2.40 g/s		
Max. flue gas mass rate	5.6 g/s	7.0 g/s	8.4 g/s	8.4 g/s	11.1 g/s	13.9 g/s
Min. flue gas temperature	40 °C	40 °C	40 °C	40 °C	40 °C	40 °C
Max. flue gas temperature	70 °C	70 °C	70 °C	70 °C	70 °C	70 °C
Approved gas-fired units	C13, C33, C43, C53	C13, C33, C43, C53	C13, C33, C43, C53	C13, C33, C43, C53	C13, C33, C43, C53	C13, C33, C43, C53
30% efficiency	109.3 %	109.3 %	109.6 %	108.5 %	109.5 %	109.4 %
NOx class	6	6	6	6	6	6
SEDBUK (2005)	A	A	A	A	A	A
SEDBUK (2009) (G20/G31)	89.3 %	89.3 %	89.3 %	89.3 %	89.3 %	89.3 %
Boiler dimension, width	440 mm	440 mm	440 mm	440 mm	440 mm	440 mm
Boiler dimension, height	720 mm	720 mm	720 mm	720 mm	720 mm	720 mm
Boiler dimension, depth	338 mm	338 mm	338 mm	338 mm	338 mm	372 mm
Mounting weight	36 kg	36 kg	36 kg	36 kg	37 kg	38 kg

	VU 306/5-5 (P-GB) ecoTEC plus 630	VU 386/5-5 (H-GB) ecoTEC plus 637	VUW 196/5-5 (H-GB) ecoTEC plus 825	VUW 246/5-5 (H-GB) ecoTEC plus 832	VUW 246/5-5 (P-GB) ecoTEC plus 832	VUW 306/5-5 (H-GB) ecoTEC plus 835
Designated country (designation in accordance with ISO 3166)	GB (Great Britain), IE (Ireland)	GB (Great Britain), IE (Ireland)	GB (Great Britain), IE (Ireland)	GB (Great Britain), IE (Ireland)	GB (Great Britain), IE (Ireland)	GB (Great Britain), IE (Ireland)
Approved unit categories	II <sub>2H3P</sub>	II <sub>2H3P</sub>	II <sub>2H3P</sub>	II <sub>2H3P</sub>	II <sub>2H3P</sub>	II <sub>2H3P</sub>
Gas connection, boiler side	15 mm	15 mm	15 mm	15 mm	15 mm	15 mm
Flow/return heating connections, boiler side	22 mm	22 mm	22 mm	22 mm	22 mm	22 mm
Hot and cold water connection, boiler side			G 3/4"	G 3/4"	G 3/4"	G 3/4"
Expansion relief valve connector (min.)	15 mm	15 mm	15 mm	15 mm	15 mm	15 mm
Air/flue gas connection	60/100 mm	60/100 mm	60/100 mm	60/100 mm	60/100 mm	60/100 mm
Condensate drain pipe-work (min.)	19 mm	19 mm	19 mm	19 mm	19 mm	19 mm
G20 natural gas flow pressure		2.0 kPa (20.0 mbar)	2.0 kPa (20.0 mbar)	2.0 kPa (20.0 mbar)		2.0 kPa (20.0 mbar)
G31 propane gas flow pressure	3.7 kPa (37.0 mbar)				3.7 kPa (37.0 mbar)	
Gas flow rate at 15 °C and 1013 mbar (based on hot water generation, if applicable), G20		4.1 m³/h	2.7 m³/h	3.4 m³/h		3.8 m³/h

## Appendix

	VU 306/5-5 (P-GB) ecoTEC plus 630	VU 386/5-5 (H-GB) ecoTEC plus 637	VUW 196/5-5 (H-GB) ecoTEC plus 825	VUW 246/5-5 (H-GB) ecoTEC plus 832	VUW 246/5-5 (P-GB) ecoTEC plus 832	VUW 306/5-5 (H-GB) ecoTEC plus 835
Gas flow rate at 15 °C and 1013 mbar (based on hot water generation, if applicable), G31	2.4 kg/h				2.5 kg/h	
Min. flue gas mass rate (G20)		3.05 g/s	1.80 g/s	2.47 g/s		2.78 g/s
Min. flue gas mass rate (G31)	4.08 g/s				2.90 g/s	
Max. flue gas mass rate	13.9 g/s	17.4 g/s	8.4 g/s	11.1 g/s	11.1 g/s	16.2 g/s
Min. flue gas temperature	40 °C	40 °C	40 °C	40 °C	40 °C	40 °C
Max. flue gas temperature	70 °C	70 °C	70 °C	70 °C	70 °C	70 °C
Approved gas-fired units	C13, C33, C43, C53	C13, C33, C43, C53	C13, C33, C43, C53	C13, C33, C43, C53	C13, C33, C43, C53	C13, C33, C43, C53
30% efficiency	108 %	109.3 %	109.6 %	109.5 %	108 %	109.4 %
NOx class	6	6	6	6	6	6
SEDBUK (2005)	A	A	A	A	A	A
SEDBUK (2009) (G20/G31)	89.3 %	89.3 %	89.3 %	89.3 %	89.3 %	89.3 %
Boiler dimension, width	440 mm	440 mm	440 mm	440 mm	440 mm	440 mm
Boiler dimension, height	720 mm	720 mm	720 mm	720 mm	720 mm	720 mm
Boiler dimension, depth	372 mm	406 mm	338 mm	338 mm	338 mm	372 mm
Mounting weight	38 kg	43 kg	36 kg	37 kg	37 kg	38 kg

	VUW 286/5-5 (H-GB) ecoTEC plus 838
Designated country (designation in accordance with ISO 3166)	GB (Great Britain), IE (Ireland)
Approved unit categories	II <sub>2H3P</sub>
Gas connection, boiler side	15 mm
Flow/return heating connections, boiler side	22 mm
Hot and cold water connection, boiler side	G 3/4"
Expansion relief valve connector (min.)	15 mm
Air/flue gas connection	60/100 mm
Condensate drain pipe-work (min.)	19 mm
G20 natural gas flow pressure	2.0 kPa (20.0 mbar)
G31 propane gas flow pressure	
Gas flow rate at 15 °C and 1013 mbar (based on hot water generation, if applicable), G20	4.2 m <sup>3</sup> /h
Gas flow rate at 15 °C and 1013 mbar (based on hot water generation, if applicable), G31	
Min. flue gas mass rate (G20)	3.05 g/s



	<b>VUW 286/5-5 (H-GB) ecoTEC plus 838</b>
Min. flue gas mass rate (G31)	
Max. flue gas mass rate	17.9 g/s
Min. flue gas temperature	40 °C
Max. flue gas temperature	70 °C
Approved gas-fired units	C13, C33, C43, C53
30% efficiency	109.4 %
NOx class	6
SEDBUK (2005)	A
SEDBUK (2009) (G20/G31)	89.3 %
Boiler dimension, width	440 mm
Boiler dimension, height	720 mm
Boiler dimension, depth	406 mm
Mounting weight	43 kg

#### Technical data – G20 power/loading G20

	<b>VU 126/5-5 (H-GB) ecoTEC plus 612</b>	<b>VU 156/5-5 (H-GB) ecoTEC plus 615</b>	<b>VU 186/5-5 (H-GB) ecoTEC plus 618</b>	<b>VU 246/5-5 (H-GB) ecoTEC plus 624</b>	<b>VU 306/5-5 (H-GB) ecoTEC plus 630</b>	<b>VU 386/5-5 (H-GB) ecoTEC plus 637</b>
Nominal heat output range P at 50/30 °C	3.3 ... 13.2 kW	3.3 ... 16.7 kW	4.1 ... 20.0 kW	5.8 ... 26.4 kW	6.5 ... 32.8 kW	7.1 ... 40.5 kW
Nominal heat output range P at 80/60 °C	3.0 ... 12.2 kW	3.0 ... 15.2 kW	3.8 ... 18.2 kW	5.2 ... 24.4 kW	5.8 ... 30.4 kW	6.4 ... 37.6 kW
Maximum heat output for hot water generation	12.2 kW	15.4 kW	18.5 kW	24.4 kW	30.4 kW	37.6 kW
Maximum heat input for hot water generation	12.4 kW	15.7 kW	18.9 kW	24.9 kW	31.0 kW	38.4 kW
Maximum heat input, heating side	12.4 kW	15.5 kW	18.6 kW	24.7 kW	30.9 kW	38.1 kW
Minimum heat input	3.2 kW	3.2 kW	4.0 kW	5.5 kW	6.2 kW	6.8 kW
Heating adjustment range	3 ... 12 kW	3 ... 15 kW	4 ... 19 kW	5 ... 24 kW	6 ... 30 kW	6 ... 38 kW
Nominal heat input efficiency (stationary) at 40/30 °C	108.0 %	109.0 %	109.0 %	108.0 %	107.0 %	107.0 %
Nominal heat input efficiency (stationary) at 50/30 °C	106.0 %	108.0 %	108.0 %	107.0 %	106.0 %	106.0 %
Nominal heat input efficiency (stationary) at 60/40 °C	101.0 %	101.0 %	101.0 %	101.0 %	101.0 %	101.0 %
Nominal heat input efficiency (stationary) at 80/60 °C	99 %	98.0 %	98.0 %	98.0 %	98.0 %	98.0 %

	<b>VUW 196/5-5 (H-GB) ecoTEC plus 825</b>	<b>VUW 246/5-5 (H-GB) ecoTEC plus 832</b>	<b>VUW 306/5-5 (H-GB) ecoTEC plus 835</b>	<b>VUW 286/5-5 (H-GB) ecoTEC plus 838</b>
Nominal heat output range P at 50/30 °C	4.1 ... 20.8 kW	5.8 ... 26.4 kW	6.5 ... 32.8 kW	7.1 ... 30.9 kW
Nominal heat output range P at 80/60 °C	3.8 ... 19.3 kW	5.2 ... 24.4 kW	5.8 ... 30.4 kW	6.5 ... 28.6 kW
Maximum heat output for hot water generation	25.4 kW	31.8 kW	35.0 kW	38.7 kW

## Appendix

	VUW 196/5-5 (H-GB) ecoTEC plus 825	VUW 246/5-5 (H-GB) ecoTEC plus 832	VUW 306/5-5 (H-GB) ecoTEC plus 835	VUW 286/5-5 (H-GB) ecoTEC plus 838
Maximum heat input for hot water generation	25.9 kW	32.4 kW	35.7 kW	39.5 kW
Maximum heat input, heating side	19.6 kW	24.7 kW	30.9 kW	28.9 kW
Minimum heat input	4.0 kW	5.5 kW	6.2 kW	6.8 kW
Heating adjustment range	4 ... 19 kW	5 ... 24 kW	6 ... 30 kW	6 ... 29 kW
Nominal heat input efficiency (stationary) at 40/30 °C	108.0 %	108.0 %	107.0 %	107.0 %
Nominal heat input efficiency (stationary) at 50/30 °C	106.0 %	107.0 %	106.0 %	107.0 %
Nominal heat input efficiency (stationary) at 60/40 °C	101.0 %	101.0 %	101.0 %	101.0 %
Nominal heat input efficiency (stationary) at 80/60 °C	98.0 %	98.0 %	98.0 %	98.0 %

### Technical data – Power/loading G31

	VU 186/5-5 (P-GB) ecoTEC plus 618	VU 306/5-5 (P-GB) ecoTEC plus 630	VUW 246/5-5 (P-GB) ecoTEC plus 832
Nominal heat output range P at 50/30 °C	5.4 ... 19.4 kW	9.4 ... 31.9 kW	6.5 ... 25.5 kW
Nominal heat output range P at 80/60 °C	5.0 ... 18.2 kW	8.5 ... 30.4 kW	6.0 ... 24.4 kW
Maximum heat output for hot water generation	18.5 kW	30.4 kW	31.8 kW
Maximum heat input for hot water generation	18.9 kW	31.0 kW	32.4 kW
Maximum heat input, heating side	18.6 kW	30.9 kW	24.7 kW
Minimum heat input	5.3 kW	9.0 kW	6.4 kW
Nominal heat input efficiency (stationary) at 40/30 °C	104.0 %	104.0 %	104.0 %
Nominal heat input efficiency (stationary) at 50/30 °C	104.0 %	103.0 %	103.0 %
Nominal heat input efficiency (stationary) at 60/40 °C	101.0 %	101.0 %	101.0 %
Nominal heat input efficiency (stationary) at 80/60 °C	98.0 %	98.0 %	98.0 %

### Technical data – Heating

	VU 126/5-5 (H-GB) ecoTEC plus 612	VU 156/5-5 (H-GB) ecoTEC plus 615	VU 186/5-5 (H-GB) ecoTEC plus 618	VU 186/5-5 (P-GB) ecoTEC plus 618	VU 246/5-5 (H-GB) ecoTEC plus 624	VU 306/5-5 (H-GB) ecoTEC plus 630
Maximum flow temperature	85 °C	85 °C	85 °C	85 °C	85 °C	85 °C
Max. flow temperature adjustment range (default setting: 75 °C)	30 ... 80 °C	30 ... 80 °C	30 ... 80 °C	30 ... 80 °C	30 ... 80 °C	30 ... 80 °C
Permissible total overpressure	0.3 MPa (3.0 bar)	0.3 MPa (3.0 bar)	0.3 MPa (3.0 bar)	0.3 MPa (3.0 bar)	0.3 MPa (3.0 bar)	0.3 MPa (3.0 bar)

	VU 126/5-5 (H-GB) ecoTEC plus 612	VU 156/5-5 (H-GB) ecoTEC plus 615	VU 186/5-5 (H-GB) ecoTEC plus 618	VU 186/5-5 (P-GB) ecoTEC plus 618	VU 246/5-5 (H-GB) ecoTEC plus 624	VU 306/5-5 (H-GB) ecoTEC plus 630
Minimum pressure for full operation	0.08 MPa (0.80 bar)	0.08 MPa (0.80 bar)	0.08 MPa (0.80 bar)	0.08 MPa (0.80 bar)	0.08 MPa (0.80 bar)	0.08 MPa (0.80 bar)
Expansion vessel capacity	10 l	10 l	10 l	10 l	10 l	10 l
Circulation water volume (with reference to $\Delta T= 20$ K)	525 l/h	662 l/h	796 l/h	796 l/h	1,049 l/h	1,307 l/h
Approx. condensate rate (pH value 3.5 to 4.0) in 50/30 °C heating mode	1.2 l/h	1.6 l/h	1.9 l/h	1.9 l/h	2.5 l/h	3.1 l/h
Remaining feed head of pump (at nominal circulation water volume)	0.025 MPa (0.250 bar)	0.025 MPa (0.250 bar)	0.025 MPa (0.250 bar)	0.025 MPa (0.250 bar)	0.025 MPa (0.250 bar)	0.025 MPa (0.250 bar)

	VU 306/5-5 (P-GB) ecoTEC plus 630	VU 386/5-5 (H-GB) ecoTEC plus 637	VUW 196/5-5 (H-GB) ecoTEC plus 825	VUW 246/5-5 (H-GB) ecoTEC plus 832	VUW 246/5-5 (P-GB) ecoTEC plus 832	VUW 306/5-5 (H-GB) ecoTEC plus 835
Maximum flow temperature	85 °C	85 °C	85 °C	85 °C	85 °C	85 °C
Max. flow temperature adjustment range (default setting: 75 °C)	30 ... 80 °C	30 ... 80 °C	30 ... 80 °C	30 ... 80 °C	30 ... 80 °C	30 ... 80 °C
Permissible total overpressure	0.3 MPa (3.0 bar)	0.3 MPa (3.0 bar)	0.3 MPa (3.0 bar)	0.3 MPa (3.0 bar)	0.3 MPa (3.0 bar)	0.3 MPa (3.0 bar)
Minimum pressure for full operation	0.08 MPa (0.80 bar)	0.08 MPa (0.80 bar)	0.08 MPa (0.80 bar)	0.08 MPa (0.80 bar)	0.08 MPa (0.80 bar)	0.08 MPa (0.80 bar)
Expansion vessel capacity	10 l	10 l	10 l	10 l	10 l	10 l
Circulation water volume (with reference to $\Delta T= 20$ K)	1,307 l/h	1,617 l/h	830 l/h	1,049 l/h	1,049 l/h	1,307 l/h
Approx. condensate rate (pH value 3.5 to 4.0) in 50/30 °C heating mode	3.1 l/h	3.8 l/h	2.0 l/h	2.5 l/h	2.5 l/h	3.1 l/h
Remaining feed head of pump (at nominal circulation water volume)	0.025 MPa (0.250 bar)	0.025 MPa (0.250 bar)	0.025 MPa (0.250 bar)	0.025 MPa (0.250 bar)	0.025 MPa (0.250 bar)	0.025 MPa (0.250 bar)

	VUW 286/5-5 (H-GB) ecoTEC plus 838
Maximum flow temperature	85 °C
Max. flow temperature adjustment range (default setting: 75 °C)	30 ... 80 °C
Permissible total overpressure	0.3 MPa (3.0 bar)
Minimum pressure for full operation	0.08 MPa (0.80 bar)
Expansion vessel capacity	10 l
Circulation water volume (with reference to $\Delta T= 20$ K)	1,230 l/h

## Appendix

	<b>VUW 286/5-5 (H-GB) ecoTEC plus 838</b>
Approx. condensate rate (pH value 3.5 to 4.0) in 50/30 °C heating mode	2.9 l/h
Remaining feed head of pump (at nominal circulation water volume)	0.025 MPa (0.250 bar)

### Technical data – Hot water handling mode

	<b>VUW 196/5-5 (H-GB) ecoTEC plus 825</b>	<b>VUW 246/5-5 (H-GB) ecoTEC plus 832</b>	<b>VUW 246/5-5 (P-GB) ecoTEC plus 832</b>	<b>VUW 306/5-5 (H-GB) ecoTEC plus 835</b>	<b>VUW 286/5-5 (H-GB) ecoTEC plus 838</b>
Lowest water volume	2.0 l/min	2.0 l/min	2.0 l/min	2.0 l/min	2.0 l/min
Water volume (at $\Delta T = 30 \text{ K}$ )	12.3 l/min	15.2 l/min	15.2 l/min	16.7 l/min	18.5 l/min
Water volume (at $\Delta T = 35 \text{ K}$ )	10.5 l/min	13.0 l/min	13.0 l/min	14.3 l/min	15.9 l/min
Water volume (at $\Delta T = 42 \text{ K}$ )	8.8 l/min	10.9 l/min	10.9 l/min	11.9 l/min	13.2 l/min
Permitted overpressure	1.0 MPa (10.0 bar)	1.0 MPa (10.0 bar)	1.0 MPa (10.0 bar)	1.0 MPa (10.0 bar)	1.0 MPa (10.0 bar)
Required connection pressure	0.035 MPa (0.350 bar)	0.035 MPa (0.350 bar)	0.035 MPa (0.350 bar)	0.035 MPa (0.350 bar)	0.035 MPa (0.350 bar)
Hot water output temperature range	35 ... 65 °C	35 ... 65 °C	35 ... 65 °C	35 ... 65 °C	35 ... 65 °C

### Technical data – Electrics

	<b>VU 126/5-5 (H-GB) ecoTEC plus 612</b>	<b>VU 156/5-5 (H-GB) ecoTEC plus 615</b>	<b>VU 186/5-5 (H-GB) ecoTEC plus 618</b>	<b>VU 186/5-5 (P-GB) ecoTEC plus 618</b>	<b>VU 246/5-5 (H-GB) ecoTEC plus 624</b>	<b>VU 306/5-5 (H-GB) ecoTEC plus 630</b>
Electric connection	230 V/50 Hz	230 V/50 Hz	230 V/50 Hz	230 V/50 Hz	230 V/50 Hz	230 V/50 Hz
Permissible connected voltage	190 ... 253 V	190 ... 253 V	190 ... 253 V	190 ... 253 V	190 ... 253 V	190 ... 253 V
Built-in fuse (slow-blow)	2 A	2 A	2 A	2 A	2 A	2 A
Min. electrical power consumption	35 W	35 W	35 W	35 W	35 W	45 W
Max. electrical power consumption	50 W	55 W	65 W	65 W	70 W	80 W
Electrical power consumption, standby	< 2 W	< 2 W	< 2 W	< 2 W	< 2 W	< 2 W
Level of protection	IP X4 D	IP X4 D	IP X4 D	IP X4 D	IP X4 D	IP X4 D

	<b>VU 306/5-5 (P-GB) ecoTEC plus 630</b>	<b>VU 386/5-5 (H-GB) ecoTEC plus 637</b>	<b>VUW 196/5-5 (H-GB) ecoTEC plus 825</b>	<b>VUW 246/5-5 (H-GB) ecoTEC plus 832</b>	<b>VUW 246/5-5 (P-GB) ecoTEC plus 832</b>	<b>VUW 306/5-5 (H-GB) ecoTEC plus 835</b>
Electric connection	230 V/50 Hz	230 V/50 Hz	230 V/50 Hz	230 V/50 Hz	230 V/50 Hz	230 V/50 Hz
Permissible connected voltage	190 ... 253 V	190 ... 253 V	190 ... 253 V	190 ... 253 V	190 ... 253 V	190 ... 253 V
Built-in fuse (slow-blow)	2 A	2 A	2 A	2 A	2 A	2 A
Min. electrical power consumption	45 W	55 W	35 W	35 W	35 W	45 W
Max. electrical power consumption	80 W	115 W	65 W	85 W	85 W	90 W
Electrical power consumption, standby	< 2 W	< 3 W	< 2 W	< 2 W	< 2 W	< 2 W

	VU 306/5-5 (P-GB) ecoTEC plus 630	VU 386/5-5 (H-GB) ecoTEC plus 637	VUW 196/5-5 (H-GB) ecoTEC plus 825	VUW 246/5-5 (H-GB) ecoTEC plus 832	VUW 246/5-5 (P-GB) ecoTEC plus 832	VUW 306/5-5 (H-GB) ecoTEC plus 835
<b>Level of protection</b>	IP X4 D	IP X4 D	IP X4 D	IP X4 D	IP X4 D	IP X4 D

	VUW 286/5-5 (H-GB) ecoTEC plus 838
<b>Electric connection</b>	230 V/50 Hz
<b>Permissible connected voltage</b>	190 ... 253 V
<b>Built-in fuse (slow-blow)</b>	2 A
<b>Min. electrical power consumption</b>	55 W
<b>Max. electrical power consumption</b>	120 W
<b>Electrical power consumption, standby</b>	< 3 W
<b>Level of protection</b>	IP X4 D

# Index

## Index

### A

Air index setting .....	24
Air/flue pipe .....	15
Air/flue pipe, installed .....	5
Appliance config. ....	26
Article number .....	9
Automatic air vent.....	21
Auxiliary relay .....	19

### B

Burner anti-cycling time.....	26
Burner anti-cycling time, resetting .....	26
Burner anti-cycling time, setting .....	26
Burner, replacing.....	29
Bypass valve, setting.....	27

### C

Calling up, diagnostics codes .....	26
Calling up, fault memory.....	28
Calling up, installer level.....	18
Carrying out, inspection work .....	33
Carrying out, maintenance work.....	33
CE label.....	9
Check programmes .....	19–20
Checking the burner .....	34
Checking, burner .....	34
Checking, CO <sub>2</sub> content .....	24
Checking, pre-charge pressure for the internal expansion vessel .....	35
Circulation pump .....	18
Cleaning, cold water inlet filter .....	35
Cleaning, heat exchanger .....	34
Clearing, fault memory .....	28
CO <sub>2</sub> content, checking.....	24
CO <sub>2</sub> content, setting .....	24
Cold water connection.....	14
Cold water inlet filter, cleaning .....	35
Combustion air supply.....	5
Comfort mode.....	19
Comfort protection mode.....	28
Compact thermal module .....	6
Compact thermal module, installing .....	35
Compact thermal module, removing .....	33
Competent person.....	4
Completing, inspection work .....	36
Completing, maintenance work.....	36
Completing, repair work .....	33
Component test .....	33
Condensate drain pipework.....	15
Condensate siphon .....	5, 23, 35
Condensate trap.....	23, 35
Connecting, controller .....	17
Connection dimensions .....	11
Contact details.....	19
Controller, connecting .....	17
Corrosion.....	6
Corrugated gas pipe.....	6

### D

Decommissioning .....	36
Decommissioning, temporarily .....	36
Diagnostics codes, calling up.....	26
Discharge pipe, expansion relief valve.....	15

Disposal, packaging .....	36
Disposing of the packaging .....	36
Documents .....	8
Draining, product.....	35

### E

Electricity .....	5
Electronics box, closing.....	16
Electronics box, opening .....	16
Electronics self-test .....	33
Ending, installation assistant.....	19

### F

Fan, replacing.....	29
Fault codes.....	28
Fault memory, calling up .....	28
Fault memory, deleting.....	28
Fault messages .....	28
Filling .....	21
Filling mode .....	19
Flue gas route .....	5
From the delivery point to the installation site .....	11
Front casing, closed .....	5
Frost .....	6
Function menu.....	33, 48

### G

Gas conversion .....	23
Gas family check, performing.....	20
Gas flow rate .....	23
Gas ratio setting .....	23
Gas restrictor.....	31
Gas valve .....	29
Gas valve, replacing.....	30

### H

Handing over to the operator.....	28
Handling .....	10
Heat exchanger, cleaning.....	34
Heat exchanger, replacing .....	31
Heating flow.....	14
Heating partial load .....	19
Heating return.....	14
Hot water connection.....	14
Hot water temperature.....	19

### I

Identification plate .....	9
If you smell flue gas.....	5
If you smell gas .....	4
Inspection work, carrying out.....	33
Inspection work, completing.....	36
Installation assistant, ending .....	19
Installation assistants, restarting .....	19
Installation site .....	5–6
Installer level, calling up .....	18
Installing, compact thermal module.....	35
Installing, unit connection piece with offset .....	16
Installing, unit connection piece, 80/125 mm diameter .....	16
Intended use.....	4
Internal expansion vessel, replacing .....	32
Isolator devices .....	36

### L

Language .....	19
Leak detection spray .....	6
Leak-tightness .....	25, 33, 36
Liquefied petroleum gas .....	13–14

Liquid gas .....	5, 13	Status codes .....	18
<b>M</b>		Switching off .....	19
Mains connection .....	17	Switching off, product .....	36
Maintenance interval, setting .....	26	Switching on .....	19
Maintenance work, carrying out .....	33	<b>T</b>	
Maintenance work, completing .....	36	Target feed temperature .....	19
Mass flow sensor, replacing .....	31	Telephone number, competent person .....	19
Minimum clearance .....	11	Test programmes .....	19, 48
Multi-functional module .....	19	Tool .....	6
<b>O</b>		Treating the heating water .....	20
Open-flued operation .....	5	Type of gas .....	14
Operating concept .....	18	<b>U</b>	
<b>P</b>		Unit connection piece for the air/flue pipe, removing .....	16
PCB and display, replacing .....	32	Unit connection piece for the air/flue pipe, replacing .....	16
PCB or display, replacing .....	32	Unit connection piece with offset, installing .....	16
Performing, gas family check .....	20	Unit connection piece, 80/125 mm diameter, installing .....	16
Power supply .....	17	Unloading the box .....	10
Pre-charge pressure for the internal expansion vessel, checking .....	35	<b>V</b>	
Preparing, repair work .....	29	Venturi .....	29
Pressure gauge .....	8–9	Venturi, replacing .....	31
Product dimensions .....	11	Voltage .....	5
Product, draining .....	35	<b>W</b>	
Product, switching off .....	36	Weight .....	12
Pump output, setting .....	27		
Pump, remaining feed head .....	27		
Purging .....	22		
<b>Q</b>			
Qualification .....	4		
<b>R</b>			
Remaining feed head, pump .....	27		
Removing, compact thermal module .....	33		
Removing, unit connection piece for the air/flue pipe .....	16		
Repair work, completing .....	33		
Repair work, preparing .....	29		
Replacing the burner .....	29		
Replacing, fan .....	29		
Replacing, gas valve .....	30		
Replacing, heat exchanger .....	31		
Replacing, internal expansion vessel .....	32		
Replacing, mass flow sensor .....	31		
Replacing, PCB and display .....	32		
Replacing, PCB or display .....	32		
Replacing, unit connection piece for the air/flue pipe .....	16		
Replacing, Venturi .....	31		
Resetting, burner anti-cycling time .....	26		
<b>S</b>			
Safety device .....	5		
Schematic drawing .....	5		
Scope of delivery .....	10		
Self-test .....	33, 48		
Serial number .....	9		
Service message .....	28		
Setting, burner anti-cycling time .....	26		
Setting, bypass valve .....	27		
Setting, CO <sub>2</sub> content .....	24		
Setting, maintenance interval .....	26		
Setting, pump output .....	27		
Side section, installing .....	13		
Side section, removing .....	13		
Spare parts .....	29		
Starting, installation assistants .....	19		





0020244997\_02

0020244997\_02 ■ 28.03.2018

**Supplier**

**Vaillant Ltd.**

Nottingham Road ■ Belper ■ Derbyshire ■ DE56 1JT

Telephone 0330 100 3461

info@vaillant.co.uk ■ www.vaillant.co.uk

© These instructions, or parts thereof, are protected by copyright and may be reproduced or distributed only with the manufacturer's written consent.

We reserve the right to make technical changes.