

# HPR10HT

Ritter Thermal High Temp HP, 10kW



## Technical Specification

- Heating Capacity Range (kW): 5.4-14.95
- Max Power Input (kW): 3.85
- Max Current Input (Amps): 24.5
- Max Output Temp: 75°C
- COP 35-30°C @ 7°C: 4.53
- COP 65-55°C @ 7°C: 2.32
- COP 35-30°C @ 2°C: 4.22
- COP 65-55°C @ 2°C: 2.02
- Refrigerant: R290
- Sound Pressure 1(m) 43dBA
- Water Connection (Inch): 1
- Water Flow Volume (m³/h): 1.7
- Pump Pressure (m/H₂O): 7.5
- Weight: 160 kg

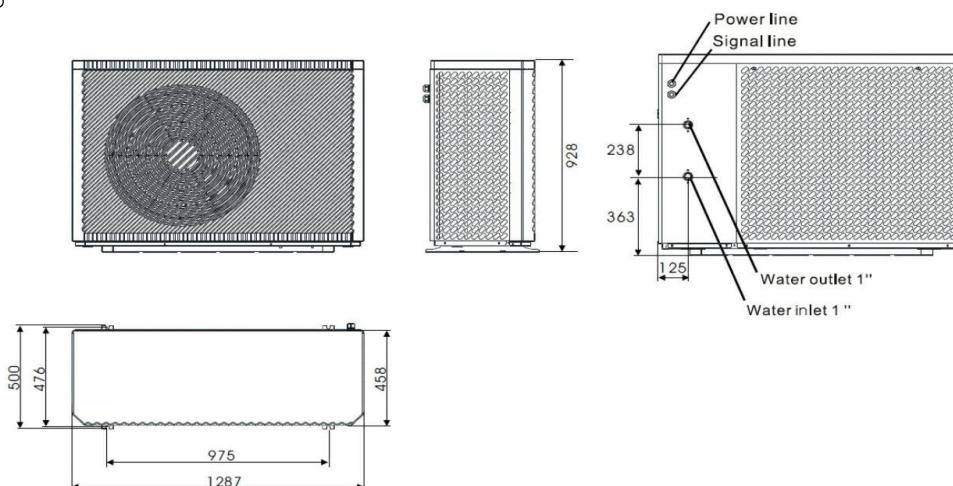

## Application

The Ritter Thermal High Temp HP, 10kW is used in heating & cooling systems to generate hot and cold water using electricity and is installed mostly outside the plant room.

## Warranty

[Download the latest warranty statement](#)

## Features

Ritter thermal is an inverter air to water heat pump with R290 refrigerant and high efficiency, optimized for underfloor, radiator & hot water applications. High quality and efficient compressor, fan and water pump is used to ensure the low noise level with insulation.

The heat pump is designed with galvanized sheet case with ASA grills

The PC microcomputer based controller is available for the users to review or set the running parameters of the heat pump with a smart phone and app control.

This series of heat pump is designed to work under different working conditions as low as -25 degrees for heating.