

HS577900

Caleffi XF Magnetic Filter 50mm



Technical Specification

Body: PA66G30
 Upper cap: brass EN 12164 CW617N
 Purge screw: brass EN 12164 CW617N
 Locking nut for tee fitting: brass EN 12420 CW617N
 Tee fitting: brass EN 1982 CB 753S
 Internal element: PA66
 Hydraulic seals: EPDM
 Internal brushes: PA66

Performance:

Full clean peak flow rate: 23m³/h
 50% clean peak flow rate: 40m³/h
 Medium: water, glycol solutions
 Maximum percentage of glycol: 30%
 Max. working pressure: 3bar
 Working temperature range: 0–90°C
 Device internal volume: 0.6 litres
 Filter mesh size: 160µm
 Ring system magnetic induction: 3 x 0,475 T

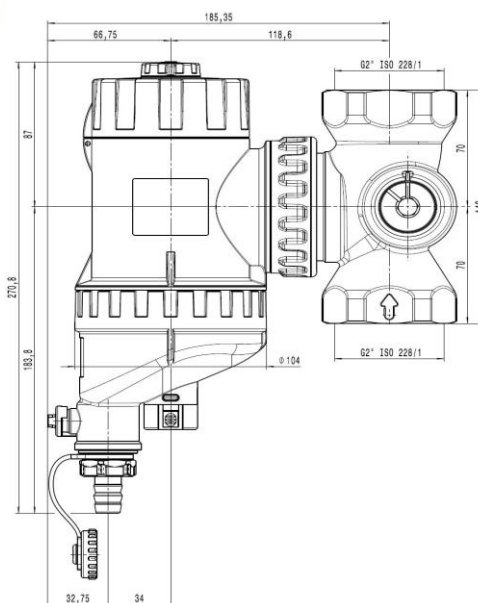
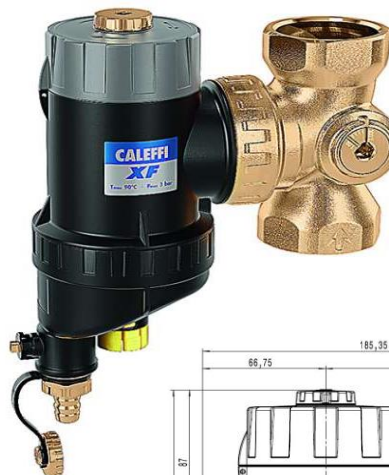

Application

The Caleffi XF Magnetic Filter 50mm is used in heating & cooling systems to clean, sterilize or treat water and is installed mostly in plant rooms.

Warranty

[Download the latest warranty statement](#)

Features

The CALEFFI XF filter separates impurities in the system right from the first passage. Its large filtration surface and impurity separation upstream of the filter also minimises the problem of mesh clogging.

Equipped with a by-pass to restrict the flow rate passing through the device and thereby increase the Kv value. We recommend 100 % filtration during commissioning and for the first few weeks of system operation. Then, during the "constant" phase, the device can be set to operate with by-pass to achieve a higher Kv.

System water is treated in three distinct steps: an initial separation mesh, a central magnet and an outlet filter.

CALEFFI XF continuously protects the generator and devices from any impurities that form in the hydraulic circuit. It can be adjusted for horizontal or vertical installation.

Internal cleaning brushes mean that maintenance can be carried out without shutting off the device.