

# Motorised temperature regulating unit for heating and cooling systems



## 167 series



### Function

The motorised temperature regulating unit is configured for use with an outside compensated or modulating temperature regulator to control the flow temperature in heating air-conditioning systems. Complete with motorised three-way mixing valve, flow and return temperature gauges, secondary circuit shut-off valves and pre-formed shell insulation.

This unit can be coupled to the 559 series SEPCOLL separator/distribution manifold with 125 mm centre distance connections and 550 series manifolds.

The safety thermostat (code 165004) and mounting bracket (code 165001) are optional.

### Product range

#### Actuator with three-point control signal

Code 167652HE3 Motorised temperature regulating unit. With PARA 25/7 pump. Centre distance 125 mm \_\_\_\_\_ DN size 25 (1")  
 Code 167662HE4 Motorised temperature regulating unit. With PARA 25/9 pump. Centre distance 125 mm \_\_\_\_\_ DN size 25 (1")

#### Actuator with 0–10 V control signal

Code 167654HE3 Motorised temperature regulating unit. With PARA 25/7 pump. Centre distance 125 mm \_\_\_\_\_ DN size 25 (1")  
 Code 167664HE4 Motorised temperature regulating unit. With PARA 25/9 pump. Centre distance 125 mm \_\_\_\_\_ DN size 25 (1")

### Unit technical specifications

#### Materials

##### Regulating unit with motorised three-way valve

Body: brass EN 12165 CW617N  
 Control stem and rotor: brass EN 12164 CW614N  
 Seals: EPDM, FKM

#### Connection pipes

Material: Fe 360 steel

#### Check valve

Body: brass EN 12164 CW614N  
 Obturator: PPAG40

#### Shut-off valves

Body: brass EN 12165 CW617N

#### Technical specifications of the actuator with three-point control signal ☹☹

Synchronous motor.  
 Control signal: Three-point  
 Electric supply: 230 V (AC)  
 Power consumption: 3 VA  
 Protection class: IP 44  
 Operating time: 150 s (90° rotation)  
 Supply cable length: 1,5 m  
 Maximum torque: 5 N·m  
 Max. ambient temperature: 55 °C  
 Maximum ambient relative humidity: 80 %

#### Technical specifications of the actuator with 0–10 V control signal ☹☹

Synchronous motor.  
 Control signal: 0(2)–10 V, 0(4)–20 mA, 0–5 V, 5–10 V  
 Feedback signal: 0–10 V  
 Electric supply: 24 V (AC)/(DC)  
 Power consumption: 2 W  
 Protection class: IP 44  
 Operating time: 75 s (90° rotation)  
 Supply cable length: 1,5 m  
 Maximum torque: 5 N·m  
 Max. ambient temperature: 55 °C  
 Maximum ambient relative humidity: 80 %

### Performance

Medium: water, glycol solutions  
 Max. percentage of glycol: 30 %  
 Maximum working pressure: 1000 kPa (10 bar)  
 Minimum working pressure: 80 kPa (0,8 bar)  
 Primary inlet working temperature range: 5–100 °C

Connections: - system side: 1" F (ISO 228-1)  
 - boiler side: 1 1/2" M (ISO 228-1)  
 - connection centre distance: 125 mm

### Insulation

Material: EPP  
 Average thickness: 30 mm  
 Density: 45 kg/m<sup>3</sup>  
 Working temperature range: -5–120 °C  
 Thermal conductivity: 0,037 W/(m·K) at 10 °C  
 Reaction to fire (UL94): class HBF

### Pump ☹☹

High-efficiency pump: models: PARA 25/7  
 PARA 25/9  
 Body: cast iron GG 15/20  
 Electric supply: 230 V - 50/60 Hz  
 Max. ambient humidity: 95 %  
 Max. ambient temperature: 40 °C

Protection class: IPX4D

Pump centre distance: 130 mm

Pump connections: 1 1/2" (ISO 228-1) with nut

### Temperature gauges

Double scale: 0–80°C (32–176°F)

### Safety thermostat kit code 165004 (optional)

Setting temperature: 55 ± 3°C  
 Protection class: IP 65  
 Contact rating: 10 A / 240 V

### Mounting bracket code 165001 (optional)

Material: stainless steel

### Head available at the regulating unit connections

Tests carried out with constant speed control.

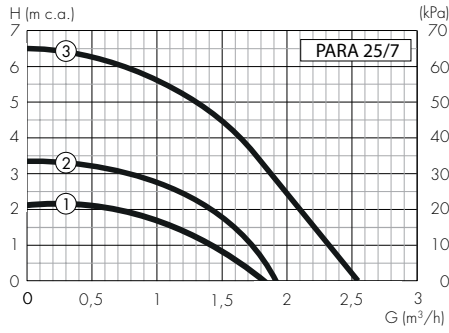

Tests carried out with constant pressure control.

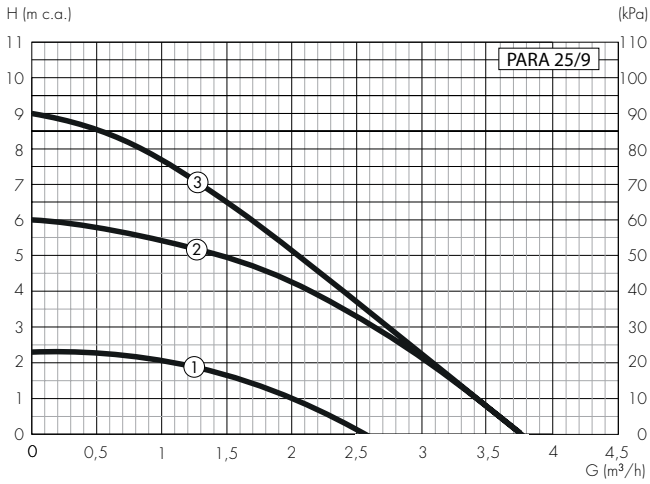

### Note:

The pumps can operate with constant speed, constant pressure and proportional pressure control, which adapts the performance to the system requirements. For further details, see the installation instruction sheet of the pump supplied in the package.

### Dimensions

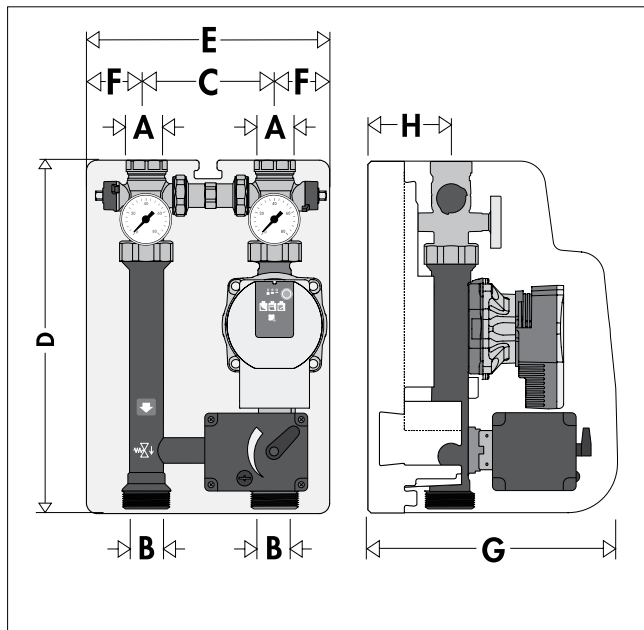

Code	A	B	C	D	E	F	G	H	Mass (kg)
167652 HE3/167654 HE3	1"	1 1/2"	125	360	247	61	255	80	7.1
167662 HE4/167664 HE4	1"	1 1/2"	125	360	247	61	255	80	9.0

### Characteristic components

1. Mixing valve with three-point actuator / 0–10V
2. PARA 25/7 or PARA 25/9 high-efficiency pump
3. Flow temperature gauge
4. Return temperature gauge
5. Shut-off valves on secondary circuit
6. Connecting pipe (with check valve)
7. Operating wrench for secondary circuit shut-off valves
8. Insulation
9. Blind stub pipe (closed)

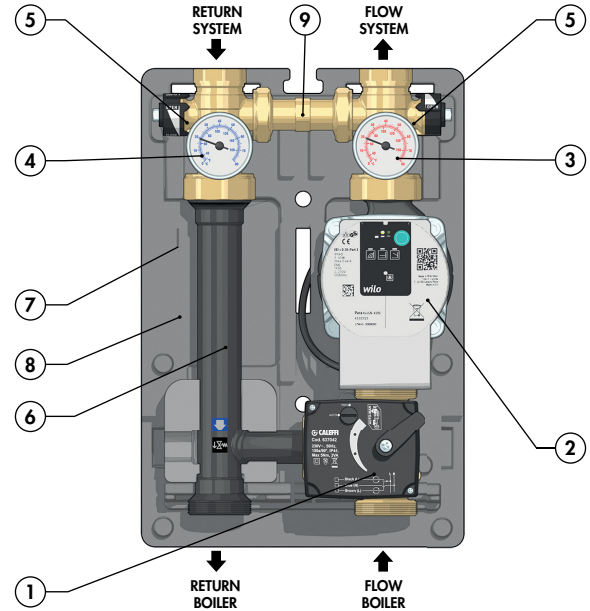

### Hydraulic diagram

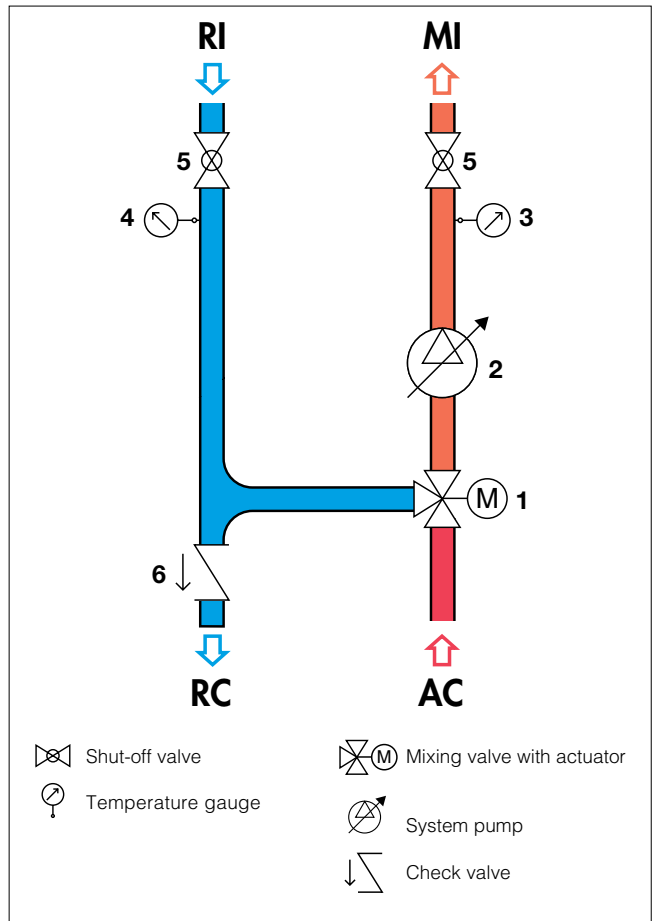

**Right hand-left hand reversibility**

The unit is assembled in the factory with right-hand side upward flow (equivalent to left-hand side downward flow). If necessary, the flow direction can be reversed. For this reason, the nuts on the unit are not fully tightened in the factory, making it easier to carry out this procedure if required. **We recommend always checking that the nuts have been fully tightened during installation.**

To make the exchange, proceed as follows:

1. Remove the insulation. The front and rear shells are easy to remove as they are slightly interlocked with each other.

2. Completely unscrew the captive nuts (using suitable spanners) located under the flow and return shut-off valves. Unscrew the captive nuts on the mixing valve, and then remove the valve and pump.

3. Remove the motor from the valve.

4. Extract the union with the universal key code 387127. Turn the valve by 180°. Insert the union into the top connection and tighten it with a suitable key. Tighten it fully.

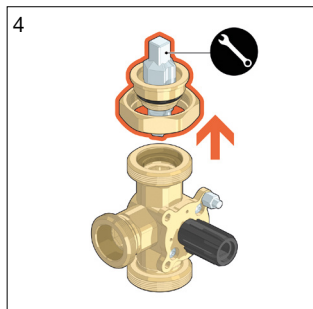
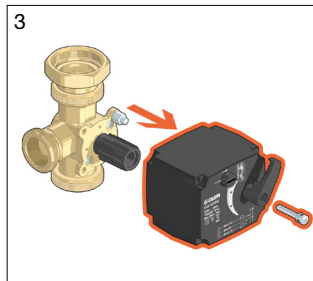
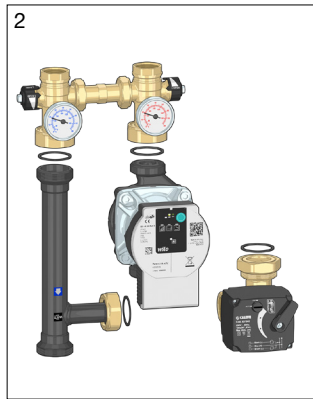
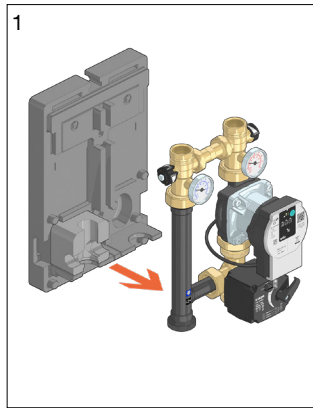
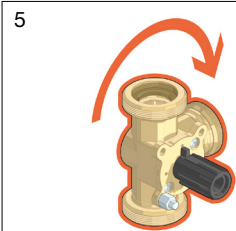

6. Turn the position indicator by hand.

7. Position the connecting pipe on the right-hand side, rotating it on its axis by 180°.

8. Invert the flow and return temperature gauges.

9. Assemble the unit as shown in the figure and fully tightening the captive nuts, taking care to position the seals correctly.

10. Assemble the motor and refit the position indicator on the actuator (fig.10a). Turn the control lever (fig. 10b)

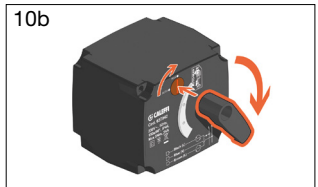
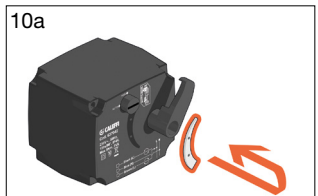
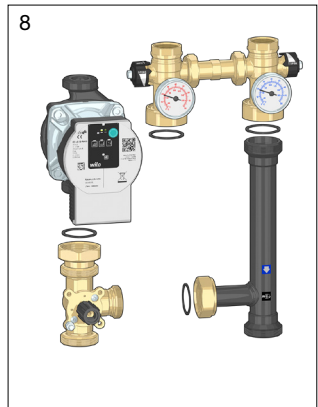
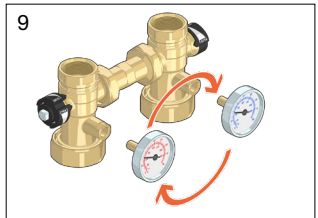
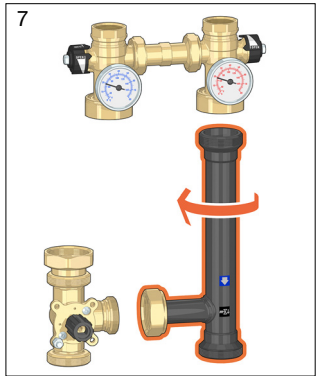
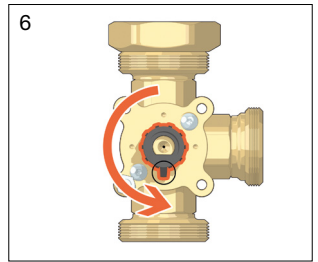

11. Fit the actuator onto the valve and secure it by tightening the corresponding screw, making sure that the actuator retainer is fully inserted. Refer to the pictures below for the correct assembly of the chosen version.

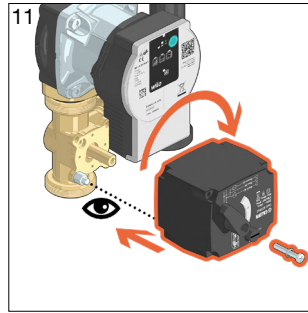

13. Assemble the insulation.

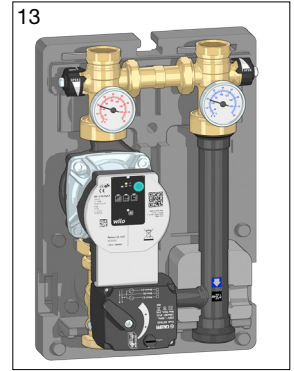

12. Move the square spacer and fit it on the right-hand side.

**Note:** The central notch in the insulation can be used to house the circulation pump and safety thermostat electrical wiring cables.

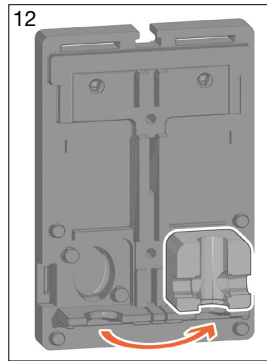

**Check the hydraulic seals of all connections before putting the unit into service.**

## Construction details

### Pre-formed shell insulation

The insulation allows use on heating and cooling systems. It is equipped with special inserts that allow improving the insulation and minimizing condensation build-up.

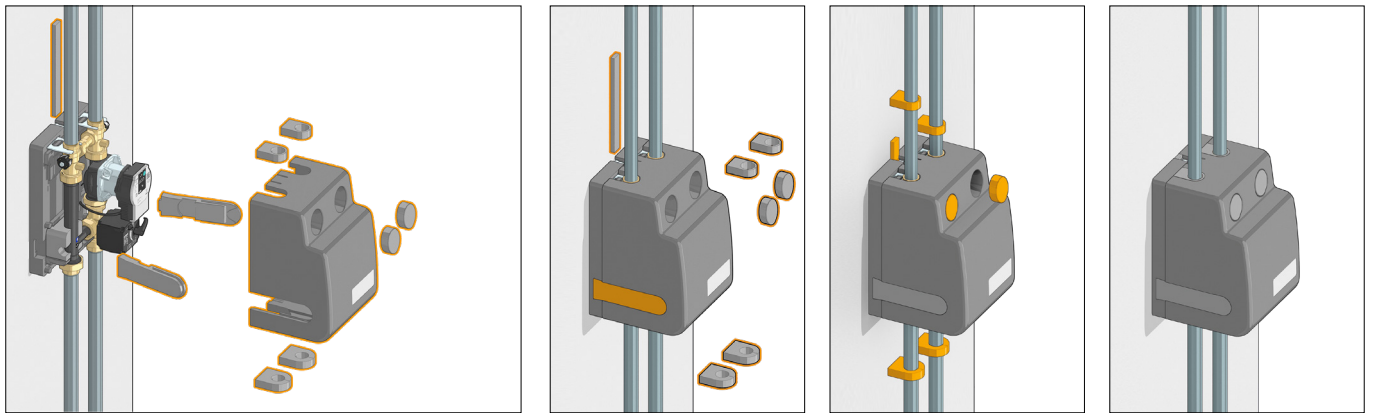

**Note:** if the maximum medium flow temperature is greater than 60°C, the two circular front caps have to be removed to prevent the circulator from overheating.

When fitting the rear shell to the assembly, it is recommended to use two ties, as shown in the figure, to ensure that the insulation adheres perfectly to the pipes and to minimize the likelihood of condensation build-up.

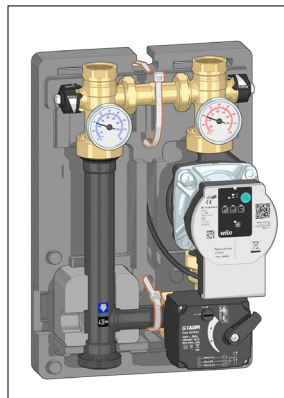

## Wiring diagrams

### Three-point actuator

Code 167652 HE3, Code 167662 HE4.

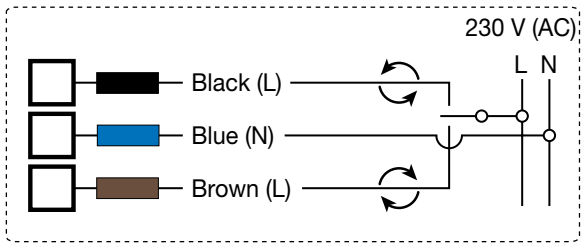

### 0-10 V actuator

Code 167654 HE3, Code 167664 HE4.

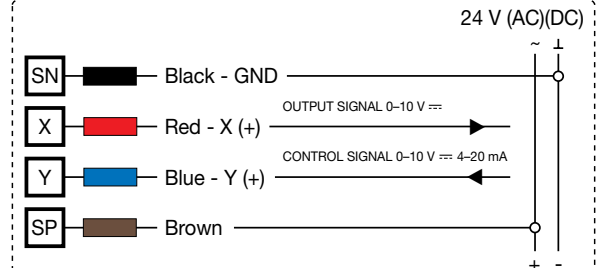

## Installation

Configuration with SEPCOLL supplied from right-hand side

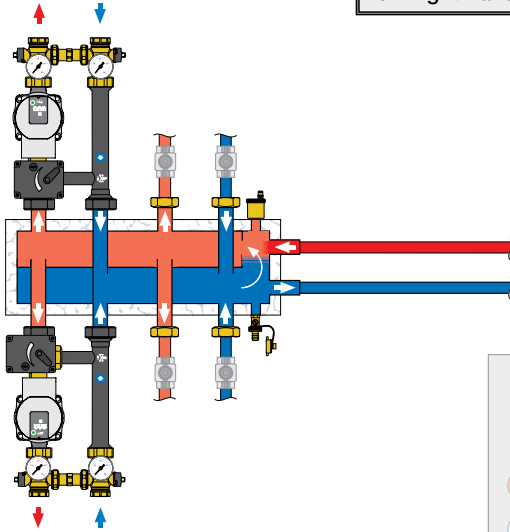

Configuration with SEPCOLL supplied from left-hand side

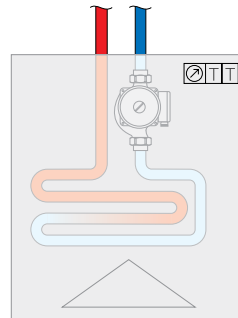
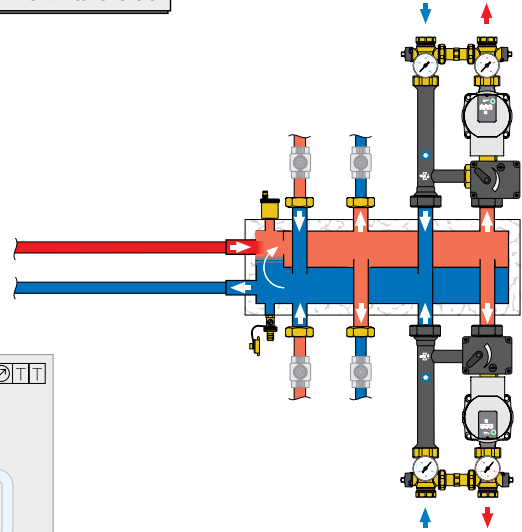

Configuration with 550 series manifold and right-hand side flow

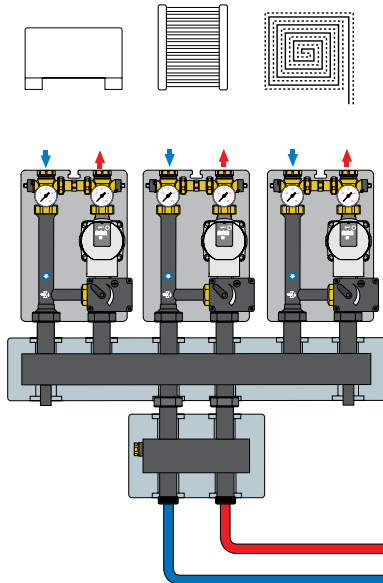

Configuration with 550 series manifold and left-hand side flow

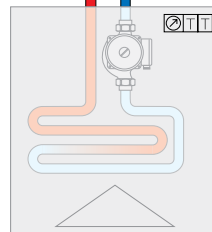
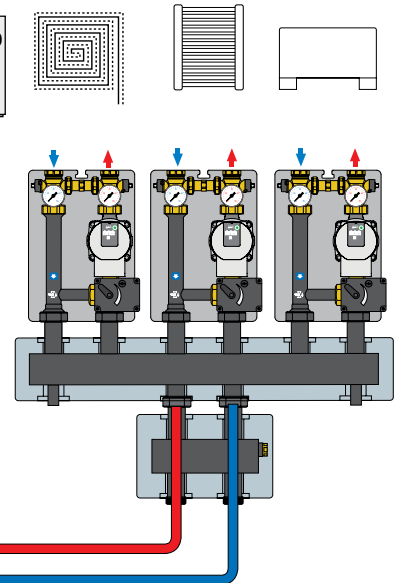

## Mounting bracket



### 165001

Mounting bracket.  
In stainless steel.

## Bracket installation

The mounting bracket for wall installation must be secured using wall anchors, using the corresponding holes on the base.

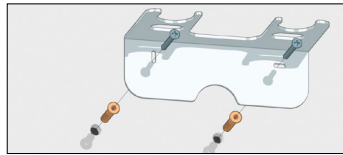

The unit should be applied to the bracket, using the corresponding seats under the hexagonal part of the shut-off valves.

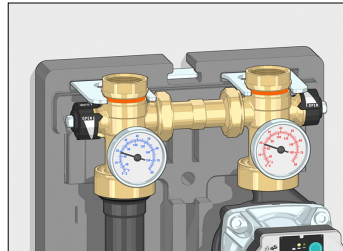

## Accessories



### 165006

Pair of eccentric tailpieces.  
Centre distance: 105-145 mm.  
Connections: 1 1/2" F with captive nut x 1" F.



### 165002

Female union with captive nut, complete with seal.  
Connections: 1 1/2" F with captive nut x 1" F.

## Example of installation

The union with captive nut allows installation of the 167 series unit on any 1" M pipe.

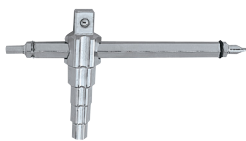
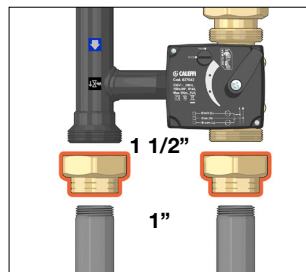

### 3871

Universal key.  
Can be used for unions from 3/8" to 1".

Code

**387127**

## Safety thermostat kit



### 165004

Safety thermostat kit for heating.  
Setting temperature 55°C ±3  
Protection class: IP 65.  
M4 thread.



### 165003

Sensor holder extension.  
1" M x 1" M connections.  
Side connections:  
M4 F x M4 F x 1/8" F x 1/4" F.

The safety thermostat kit is used to control the maximum flow temperature to the system. In the event of overheating, it commands the regulator to stop the pump, thus preventing the system from being damaged. To facilitate positioning of the bulb, the sensor holder extension **code 165003** can be installed on the regulating unit flow line.



## Electrical connection

For safety thermostat electric connection details, please refer to the documentation corresponding to the three-point controller.



**Regulators compatible with actuators with 3 points / 0-10 V**



**161**

Digital regulator with functional synoptic diagram for heating and cooling complete with immersion flow probe and Ø 6 mm PT1000 return probe (pocket to be chosen according to the pipe, see accessories).  
 Optional climatic probe.  
 Adjustment temperature range: 5-95 °C.  
 Electric supply: 230 V - 50/60 Hz.  
 Control signal: 3-point, 0-10 V.  
 Protection class: IP 20 / EN 60529.  
 Probe cable length: 1.5 m.



Code

**161010**



**1520**

Climate regulator complete with digital flow probes and external probe.  
**Compatible with three-point actuator.**  
 Adjustment range: 20-90 °C.  
 Electric supply: 230 V - 50 Hz.  
 Protection class: IP 40.



Code

- |               |                 |
|---------------|-----------------|
| <b>152001</b> | with 1 channel  |
| <b>152002</b> | with 2 channels |
| <b>152003</b> | with 3 channels |

**Coupled with 161 series controller**

Replace both temperature gauges with the special pockets for the 161 series supplied in the 167 unit package.

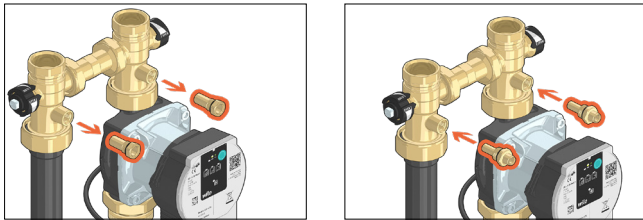

**Coupled with 1520 series controller**

Replace the flow temperature gauge with the special pocket for the 1520 series supplied in the 167 unit package.

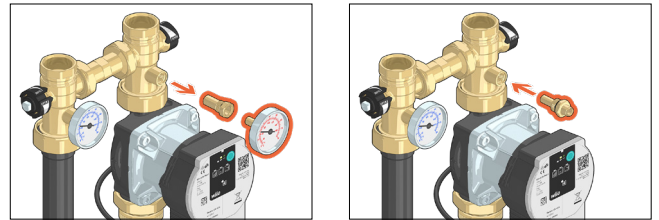

**Application diagrams**

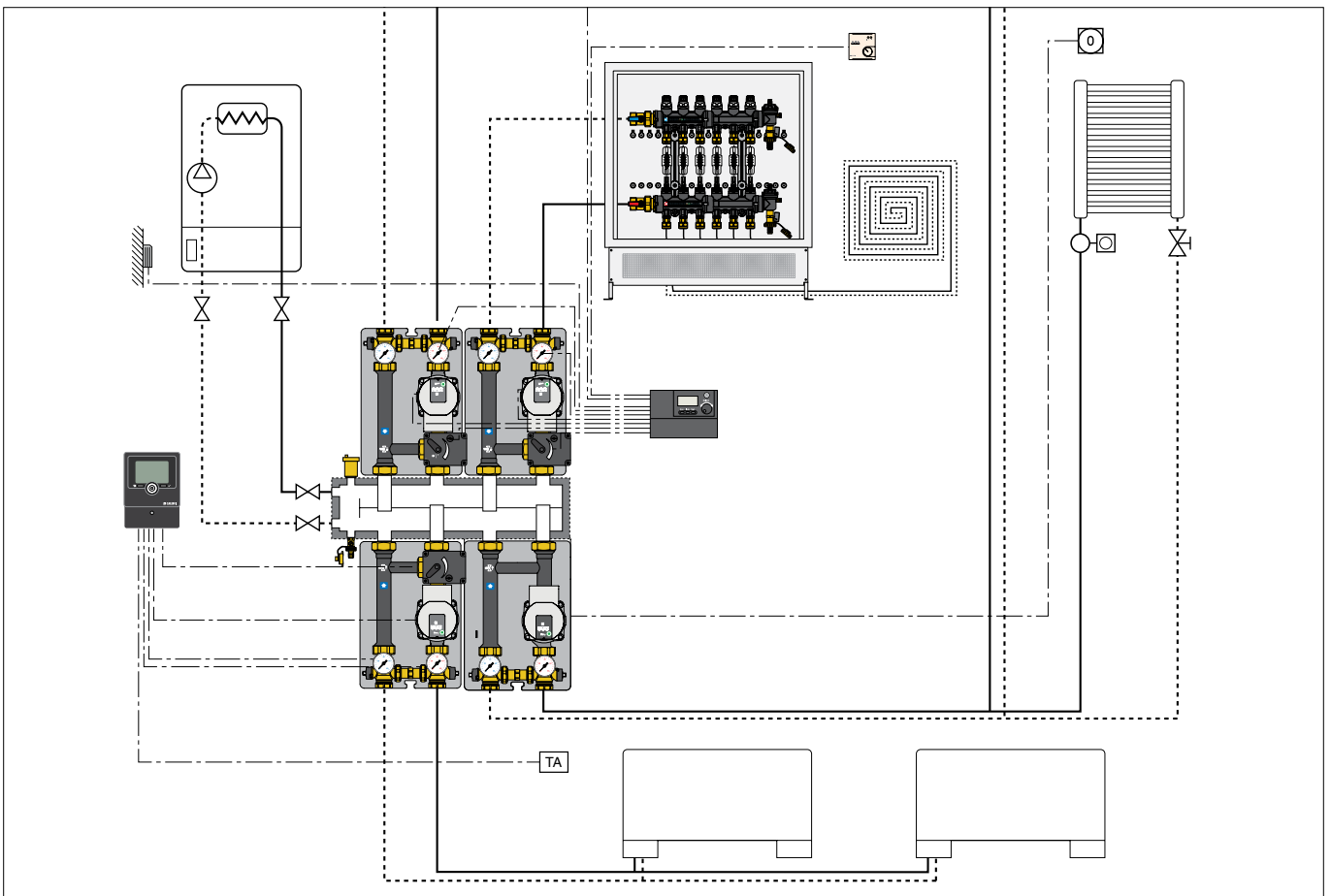

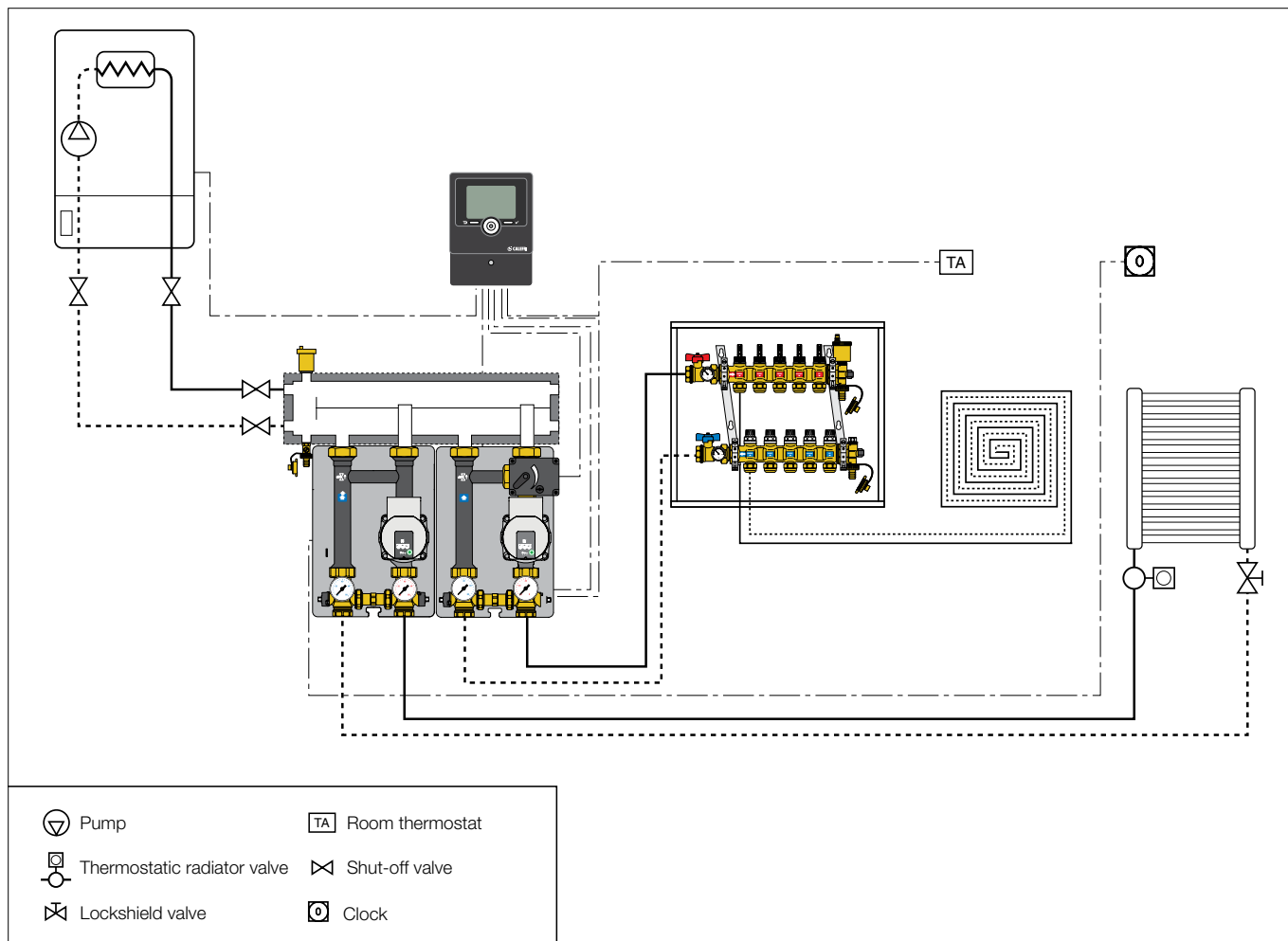

## SPECIFICATION SUMMARY

### 167 series

Motorised temperature regulating unit for heating and cooling systems. Regulation with three-way sector valve. Right-left swappable. Connections to primary circuit 1 1/2" M (ISO 228-1). Connections to secondary circuit 1" F (ISO 228-1). Connection centre distance to the primary and secondary circuit 125 mm. Maximum working temperature 100°C. Maximum working pressure 1000 kPa (10 bar). Complete with: three-way sector regulating valve, brass body, brass obturator. Actuator with three-point control signal (codes 167652 HE3 - 167662 HE4), electric supply 230 V, protection class IP 44, operating time (90° rotation) 150 s. Actuator with 0–10 V control signal (codes 167654 HE3 - 167664 HE4), electric supply 24 V, protection class IP 44, operating time (90° rotation) 75 s. PARA 25/7 (PARA 25/9) high-efficiency pump, protection class IPX4D; Dual-scale temperature gauges 0–80°C (32–176°F); secondary circuit shut-off valves. With pre-formed shell insulation in EPP.

#### Code 165004

Safety thermostat kit, setting temperature 55±3 °C, protection class IP 65. M4 thread.

#### Code 165001

Stainless steel mounting bracket.

#### Code 165002

Female union with captive nut, complete with seal. Connections 1 1/2" F with nut x 1" F (ISO 228-1).

#### Code 165003

Sensor holder extension. Connections 1" M x 1" F (ISO 228-1) with captive nut.

We reserve the right to make changes and improvements to our products and the related technical data in this publication, at any time and without prior notice. The website [www.caleffi.com](http://www.caleffi.com) always has the most up-to-date version of the document, which should be used for technical verifications.