

# HPRMPS100

Ritter Buffer Tank 100L



## Technical Specification

- Net Weight: 30kg
- Construction: Stainless steel
- Nominal capacity: 100L
- Max pressure: 3 bar
- Min Pressure: 0.3 bar
- Max temperature: 85°C
- Min temperature: 5°C
- Installation options: Floor or wall
- Dimensions: 1100mm x 470mm diameter
- Connections: 1" Female

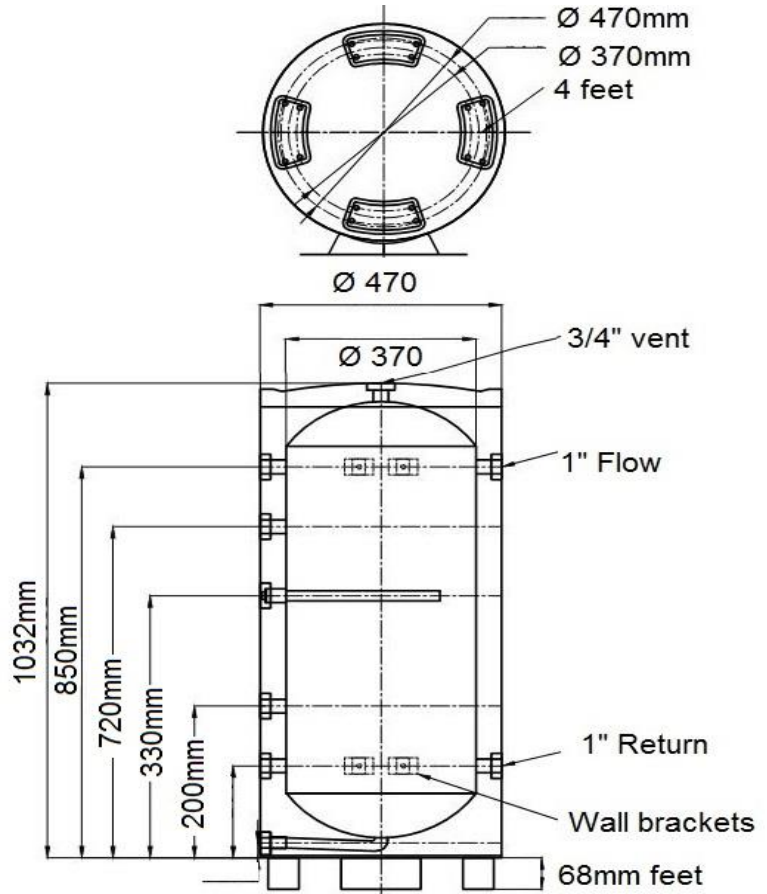

## Application

The Ritter Buffer Tank 100L is used in heating & cooling systems to control functionality of the system and is installed mostly in plant rooms.

## Warranty

[Download the latest warranty statement](#)

## Features

100 litre compact floor or wall mounted buffer cylinder for hydraulic isolation.

Suitable for heating & cooling applications.

Convenient configuration for cascading dual heat pumps, hybrid HP & boiler applications and hydraulic separation between heat pump and full zone control underfloor systems.

1" Connections for high flow rates