

HPRMPS200

Ritter Buffer Tank 200L



Technical Specification

- Net Weight: 35kg
- Construction: Stainless steel
- Nominal capacity: 200L
- Max pressure: 3 bar
- Min Pressure: 0.3 bar
- Max temperature: 85°C
- Min temperature: 5°C
- Installation options: Floor or wall
- Dimensions: 1350mm x 560mm diameter
- Connections: 1&1/4" Female

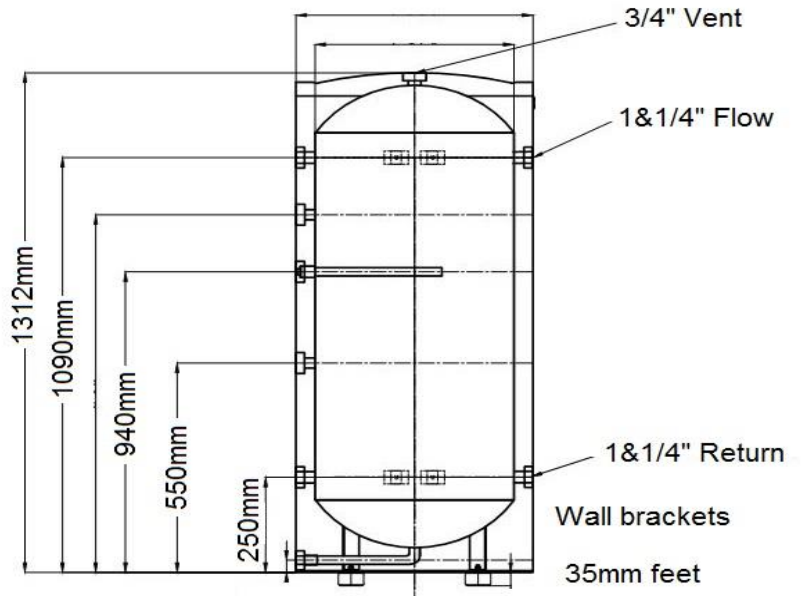
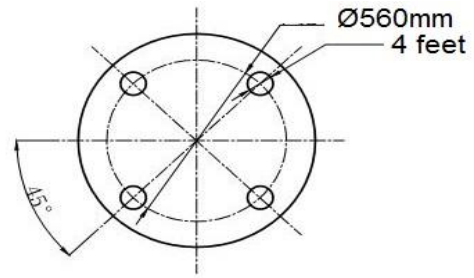

Application

The Ritter Buffer Tank 200L is used in heating & cooling systems to control functionality of the system and is installed mostly in plant rooms.

Warranty

[Download the latest warranty statement](#)

Features

200 litre compact floor or wall mounted buffer cylinder for hydraulic isolation.

Suitable for heating & cooling applications.

Convenient configuration for cascading dual heat pumps, hybrid HP & boiler applications and hydraulic separation between heat pump and full zone control underfloor systems.

1&1/4" Connections for high flow rates