

HPRMPS50

Ritter Buffer Tank 50L



Technical Specification

- Net Weight: 25kg
- Construction: Stainless steel
- Nominal capacity: 50L
- Max pressure: 3 bar
- Min Pressure: 0.3 bar
- Max temperature: 85°C
- Min temperature: 5°C
- Installation options: Floor or wall
- Dimensions: 600mm x 470mm diameter
- Connections: 1" Female

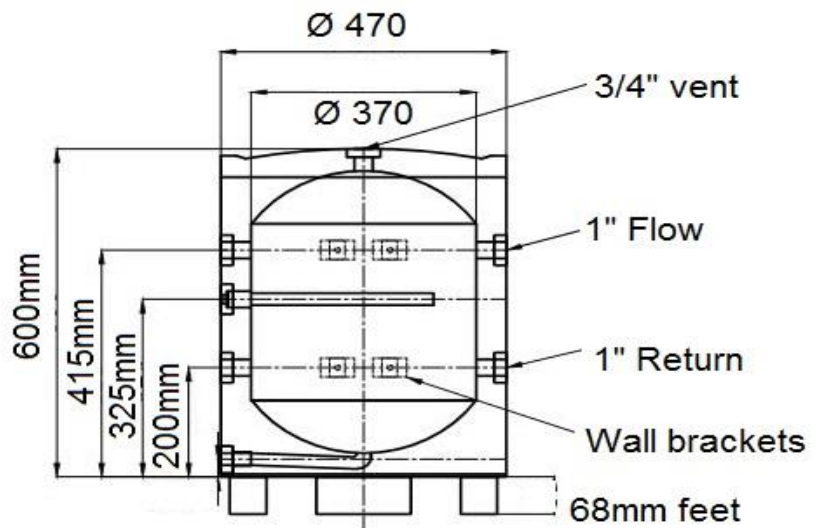
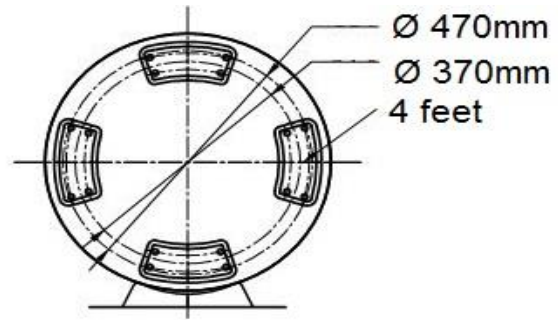

Application

The Ritter Buffer Tank 50L is used in heating & cooling systems to control functionality of the system and is installed mostly in plant rooms.

Warranty

[Download the latest warranty statement](#)

Features

50 litre compact floor or wall mounted buffer cylinder for hydraulic isolation.

Suitable for heating & cooling applications.

Convenient configuration for cascading dual heat pumps, and hydraulic separation between heat pump and full zone control underfloor systems.

Not suitable for hybrid systems.

1" Connections for high flow rates