

DSV527410

Caleffi 527 Series Safety Valve 15mm x 20mm  
100kPa



### Technical Specification

- Body: brass EN 12165 CW617N
- Cover: brass EN 12165 CW617N
- Control Stem: brass EN 12164 CW614N
- Obturator Seal: EPDM
- Diaphragm: EPDM
- Spring: steel EN 12270-1
- Control Knob: PA6G20
- Nominal Pressure: PN10
- Working Temperature Range: 5-110°C

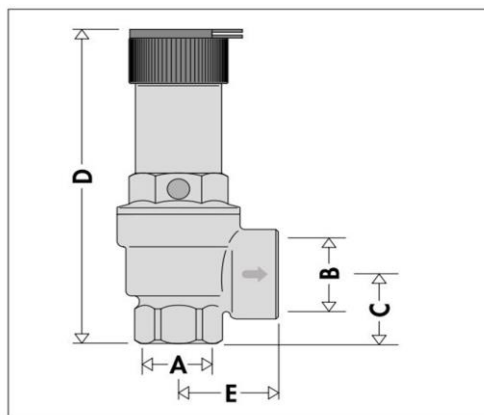

Code	A	B	C	D	E
5274.. EST	1/2"	3/4"	26	93	33
5275.. EST	3/4"	1"	30	136	39,5
5276.. EST	1"	1 1/4"	39	166	48
5277.. EST	1 1/4"	1 1/2"	42,5	185	56



### Application

The Caleffi 527 Series Safety Valve 15mm x 20mm 100kPa is used in plumbing systems to provide a safety function and is installed mostly in plant rooms.

### Warranty

[Download the latest warranty statement](#)

### Features

- The standard safety relief valves 527 series are used in heating systems, in domestic water systems to protect the hot water storage and in hydraulic systems.
- 527 EST series valves are fail-safe devices, i.e. they are guaranteed to operate even in the case of wear or breakage of the diaphragm.
- 15mm x 20mm outlet, 100kPa
- Female connections