

Set point thermostatic regulating unit with distribution kit for primary circuit

182 series



01192/18 GB
replaces dp 01192/15 GB



Function

The temperature regulating unit with primary circuit distribution kit has been developed for use in mixed installation solutions: radiant panels and radiators, in conjunction with distribution manifolds for radiant panels.

The set point regulating unit performs the function of keeping the flow temperature constant, at the set value, for the medium distributed in a low temperature system for floor radiant panels.

In this particular series, the temperature is regulated by a specific hydraulic unit equipped with a thermostatic three-way valve with a built-in sensor.

The function of the kit is to distribute a portion of the medium flowing from the primary boiler circuit to the heating elements.

It is supplied complete with manifolds with built-in shut-off and regulating valves and an adjustable differential by-pass kit for the primary circuit. The latter accessory is essential when there is a primary circuit circulation pump and the radiator circuits are controlled by thermostatic or thermo-electric valves.

Reference documentation

- Tech. broch. 01126 Manifolds in composite specifically designed for 670 series radiant panel systems.

Product range

Code 1826.1A2L 002 Pre-assembled set point thermostatic regulating unit with manifolds and box, distribution kit for primary circuit, with UPM3 Auto L 25-70 pump

Technical specifications

Materials

Regulating unit with thermostatic three-way valve

Body: brass EN 1982 CB753S
Headwork: brass EN 12164 CW614N
Obturator: PSU
Seals: EPDM

Flow adapter unit

Body: brass EN 1982 CB753S

Primary circuit by-pass kit

Body: brass EN 1982 CB753S
By-pass valve: PA6G30
Spring: stainless steel EN 10270-3 (AISI 302)

Primary circuit distribution manifolds

Flow manifold

Body: brass EN 1982 CB753S

Flow rate regulating valve

Obturator: brass EN 12164 CW614N
Hydraulic seals: EPDM

Return manifold

Body: brass EN 1982 CB753S

Shut-off valve

Obturator stem: stainless steel EN 10088-3 (AISI 303)
Obturator and seals: EPDM
Springs: stainless steel EN 10270-3 (AISI 302)
Knob: ABS

Performance

Medium: water, glycol solutions
Max. percentage of glycol: 30%
Adjustment temperature range: 25–55°C
Accuracy: ±2°C
Primary inlet max. temperature: 90°C
Maximum working pressure: 600 kPa (6 bar)
Minimum working pressure: 80 kPa (0,8 bar)

Panel manifold differential by-pass setting (optional, code 182000):
25 kPa (2.500 mm w.g.)

Primary circuit differential by-pass setting range: 2–30 kPa (0,2–3 m w.g.)

Primary circuit manifold average inner diameter: Ø 20 mm

Liquid crystal digital thermometer scale: 24–48°C

Pressure gauge scale: 0–10 bar

Connections: - primary circuit: 1" F (ISO 228-1)
- to regulating unit: 1" F (ISO 228-1) with nut
- panel circuit outlets: 3/4" for coupling with adapter code 675850

- outlet centre distance: 50 mm

- primary circuit manifold outlets: 3/4" M - Ø 18 mm

- outlet centre distance: 50 mm

Panel circuit differential by-pass graph

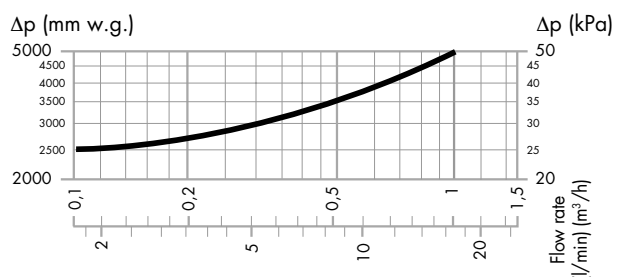

Safety thermostat

Factory setting: 55°C ±3°C
 Protection class: IP 55
 Contact rating: 10 A/240 V

Electrical connection diagram

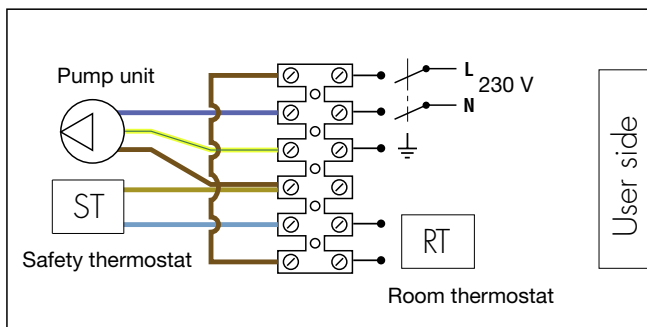

Pump

High-efficiency pump: model UPM3 Auto L 25-70
 Body: cast iron GG 15/20
 Electric supply: 230 V - 50 Hz
 Max. ambient humidity: 95%
 Max. ambient temperature: 70°C
 Protection class: IP 44
 Pump centre distance: 130 mm
 Pump connections: 1 1/2" F (ISO 228-1) with nut

Head available at the regulating unit connections

Tests carried out with constant speed control.

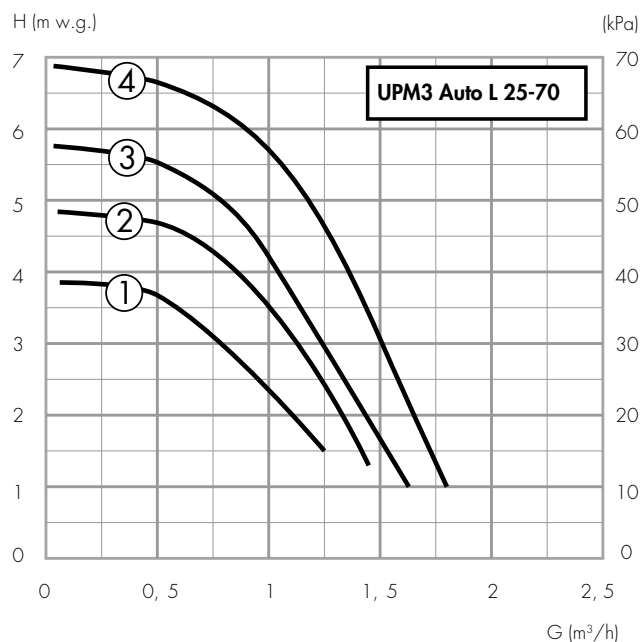

Note:

The pump can operate with constant speed, constant pressure and proportional pressure control, which adapts the performance to the system requirements. For further details, see the installation instruction sheet of the pump supplied in the package.

Dimensions

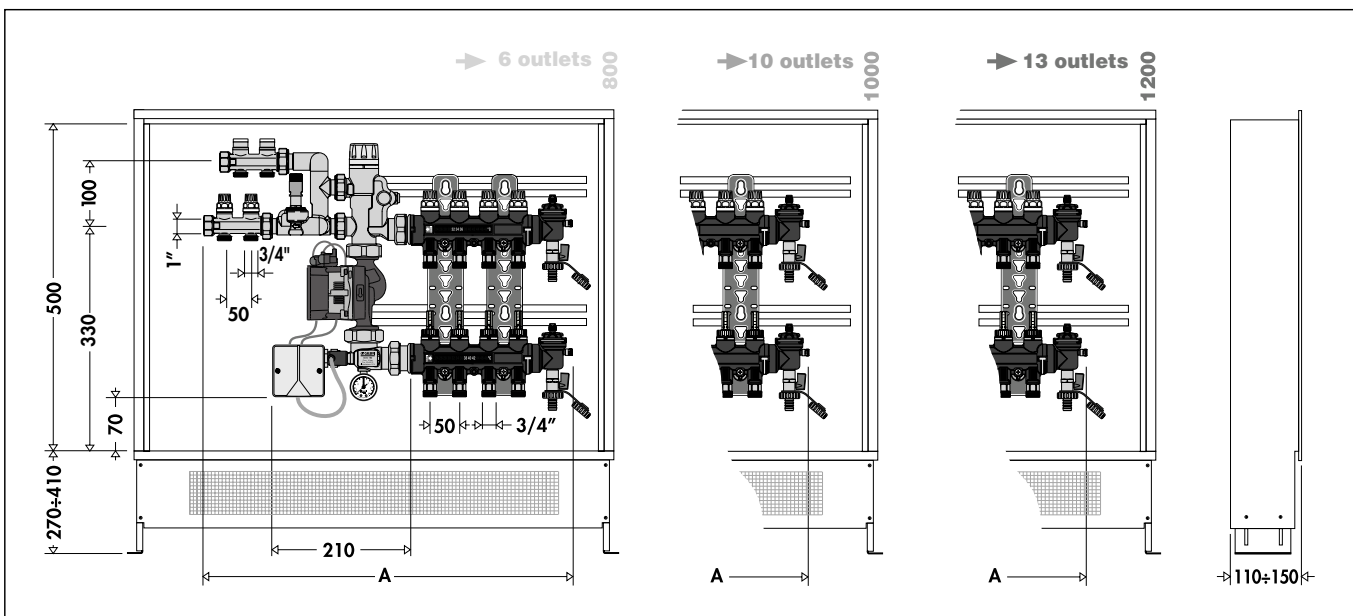

Code	1826C1 002	1826D1 002	1826E1 002	1826F1 002	1826G1 002	1826H1 002	1826I1 002	1826L1 002	1826M1 002	1826N1 002	1826O1 002
Radiators outlet	2	2	2	2	2	2	2	2	2	2	2
Panel outlets	3	4	5	6	7	8	9	10	11	12	13
A	565	615	665	715	765	815	865	915	965	1015	1065

Characteristic components

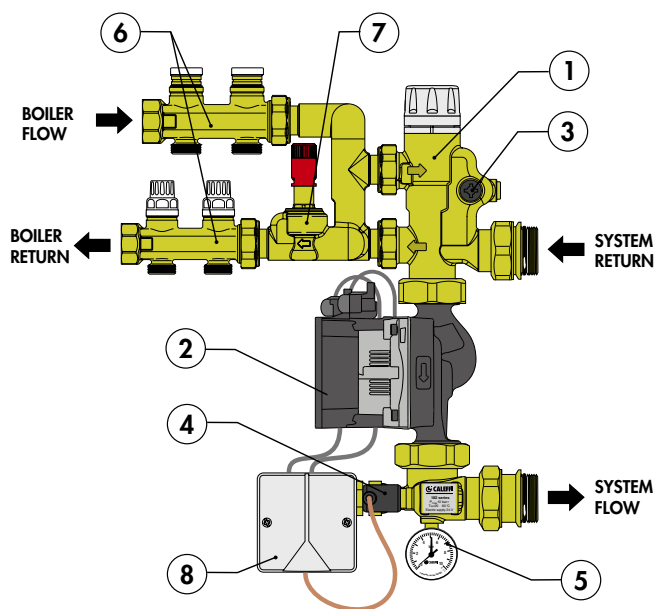

Return manifold equipped with shut-off valves.

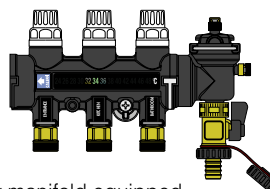

Flow manifold equipped with flow meters and balancing valves.

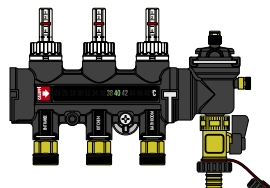

End fittings with automatic air vent and fill/drain cock.

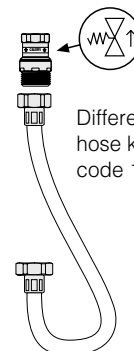

Differential by-pass hose kit (optional, code 182000)

- 1 Thermostatic three-way mixing valve with built-in sensor
- 2 High-efficiency pump UPM3 Auto L 25-70
- 3 Fitted for adjustable drain valve
- 4 Safety thermostat

- 5 Pressure gauge
- 6 Primary circuit distribution manifolds
- 7 Primary circuit differential by-pass kit
- 8 Electrical wiring box

Hydraulic diagram

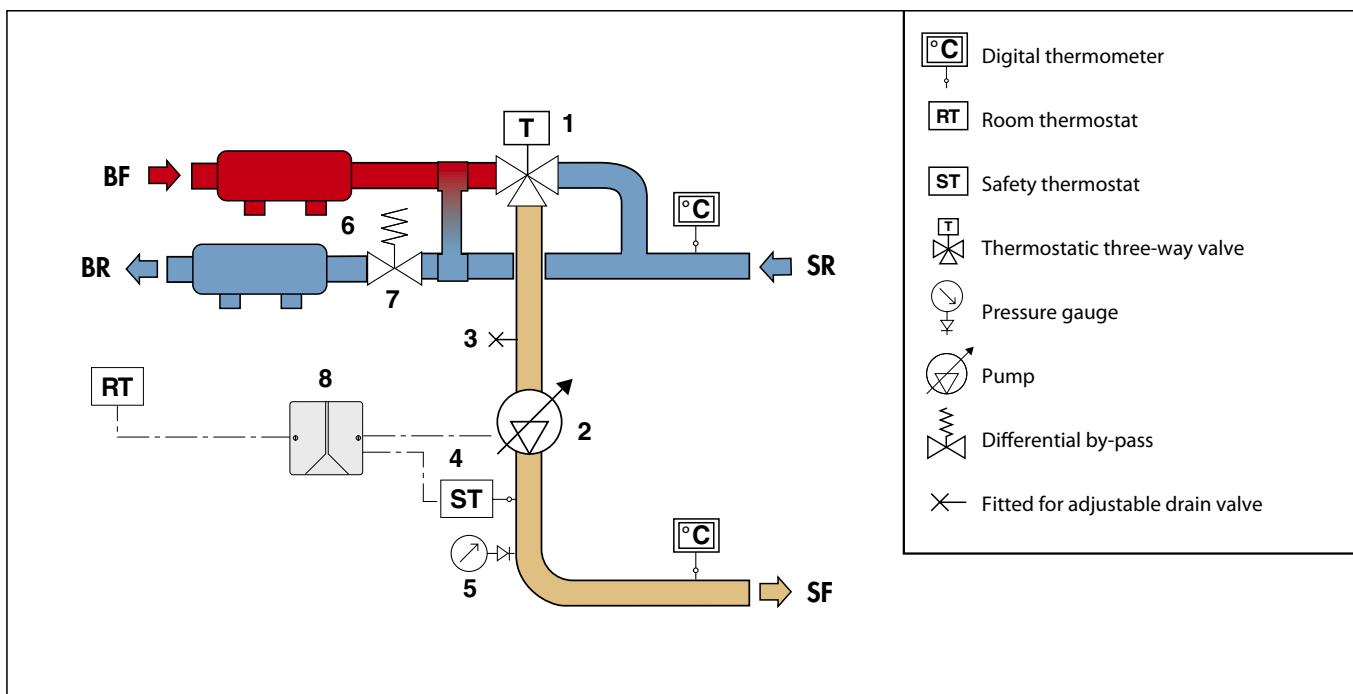

Operating principle

The regulator element inside the thermostatic three-way valve consists of a temperature sensor (1) fully immersed in the mixed water outlet chamber. By expanding and contracting, it continuously ensures a correct proportioning of hot water, coming from the boiler, and water returning from the panel circuit.

The water intake is regulated by a shaped obturator (2) that slides inside a special cylinder placed between the hot water flow (3) and the water returning from the circuit (4).

Even if the thermal load of the secondary circuit or the inlet temperature from the boiler changes, the mixing valve automatically adjusts the flow rates until it obtains the set temperature.

Construction details

Regulating unit body

The valve body, containing the temperature regulating device, is made out of a single casting with connections to the primary and secondary circuits. A specific internal channel carries the system return medium to the regulating valve, making it possible for the unit to be smaller in size and easy to connect.

Reduced head losses

The three-way mixing valve is equipped with a special obturator that acts on calibrated water orifices. This ensures a high flow rate and a reduced size, while maintaining accurate temperature control.

Anti-seizing materials

The materials used for the mixing valve construction eliminate potential seizure due to scale. All functional parts, such as the obturator, valve seats and guides, have been made using a special material with low friction coefficient, which ensures product performance over time.

Low-inertia thermostatic sensor

The temperature-sensitive element, the "engine" of the thermostatic three-way valve, has low thermal inertia; in this way it can quickly react to changes in the conditions of inlet pressure and temperature, shortening the valve response time to the changes in thermal load.

Temperature adjustment and locking

The control knob is used to adjust the temperature in a full turn (360°) between min. and max. It also has a tamper-proof system for locking the temperature at the set value.

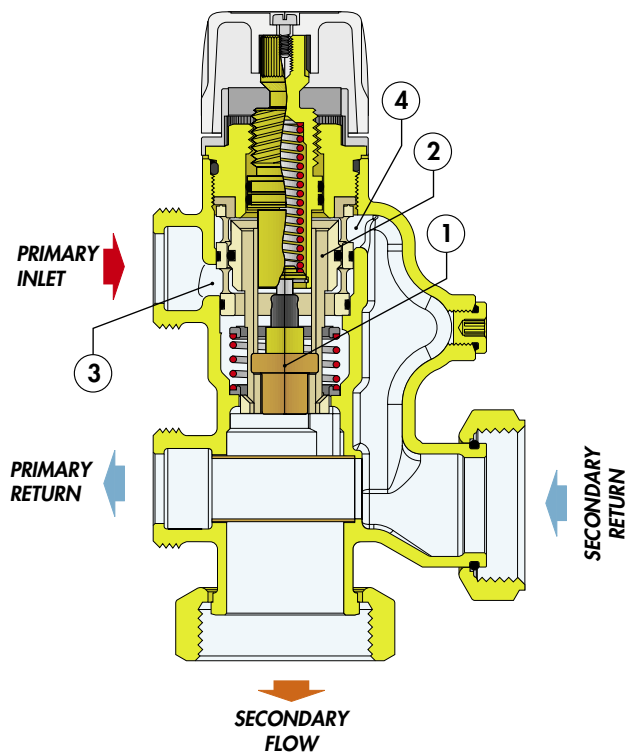

Flow unit

The flow unit is made out of a single casting with the necessary ports to connect the functional components such as the safety thermostat and the pressure gauge.

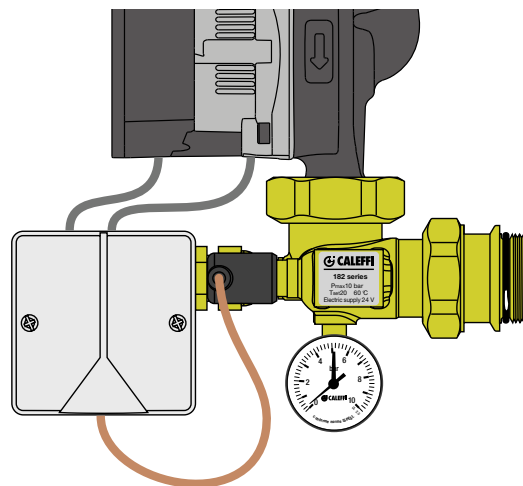

Adjustment locking

Turn the knob onto the required number, unscrew the upper screw, remove the knob and put it back on so that the internal reference couples with the protrusion on the knob holder nut.

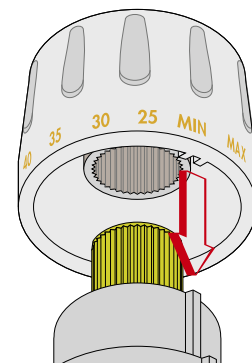

Distribution and differential by-pass kit for primary circuit

Operating principle

The distribution and differential by-pass kit for the primary circuit enables controlling the flow supplied to the heating elements connected before the outlet to the regulating unit for the panel circuit.

It is composed of distribution manifolds with built-in regulating and shut-off valves and adjustable differential by-pass kit for the primary circuit.

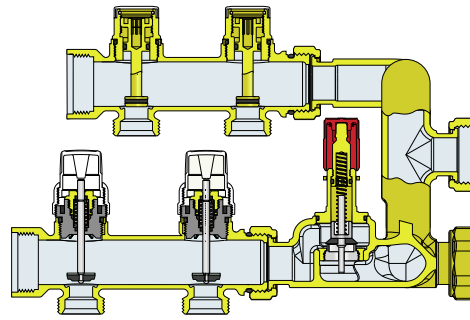

Primary circuit distribution manifolds

The distribution manifolds are equipped with:

- flow rate regulating valves built into the flow manifold. This means it is possible to set the right flow rate and balance the various connected circuits.
- shut-off valves built into the return manifold. The same circuits can be automatically shut off by using the thermo-electric actuators.

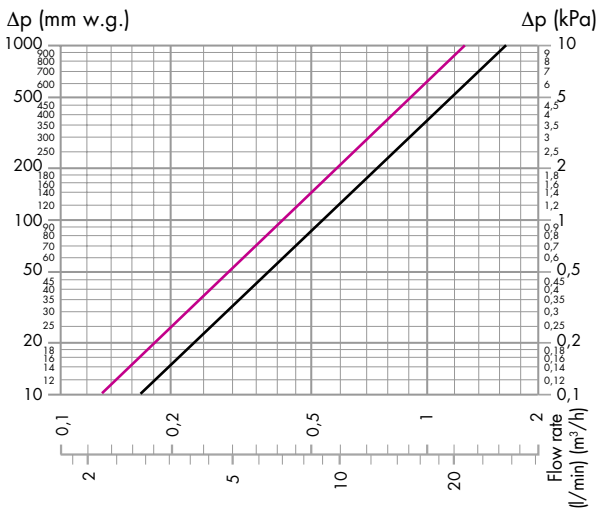

	Kv	Kv _{0,01}
Flow rate regulating valve fully open	5,40	540
Shut-off valve	4,10	410

- Kv = flow rate in m³/h for a head loss of 1 bar
- Kv_{0,01} = flow rate in l/h for a head loss of 1 kPa

Hydraulic characteristics of the flow rate regulating valve

Adjustment position	Kv(m ³ /h)	Kv _{0,01} (l/h)
2 turns	0,22	22
3 turns	1,30	130
4 turns	3,20	320
5 turns	4,70	470
F.O.	5,40	540

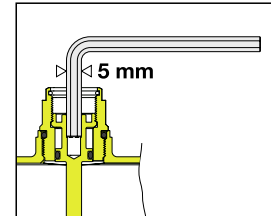

Differential valve

The differential valve is used to control the head in the primary distribution circuit. It aids flow circulation towards the heating elements and limits overpressure if there are thermostatic or thermo-electric valves.

The differential valve setting can be adjusted. It is preset to 5 kPa, the mean value for the loss of head in the primary circuit. If necessary, the trigger value can be adjusted within the range 2–30 kPa (0,2–3 m w.g.), using the corresponding knob with graduated scale.

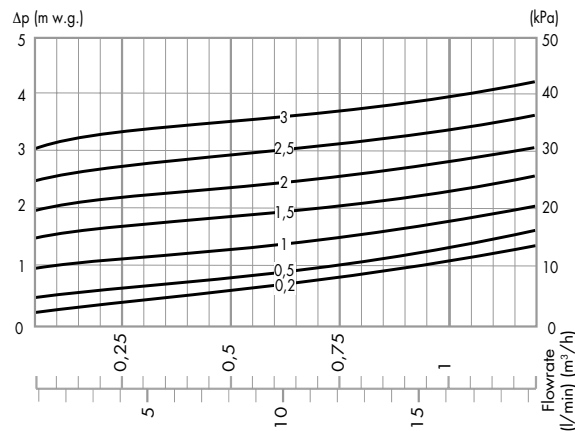

Primary circuit by-pass kit

The by-pass kit permits hydraulic separation between the primary and secondary circuits. This hydraulic separation optimizes the operation of the secondary circuit at the panels thus preventing the influence on the secondary circuit by any primary circuit flow rate variation. In this case, the flow rate in the respective circuits depends exclusively on the flow rate characteristics of the pumps, preventing reciprocal influence caused by connection in series. Two possible conditions of hydraulic balance are described here. The component is typically sized in order to have the following working rate:

$$G_{\text{primary}} = G_{\text{secondary}} \text{ (inlet to the mixing valve)} + G_{\text{heating elements}}$$

G_{primary} maximum recommended: 1,5 m³/h

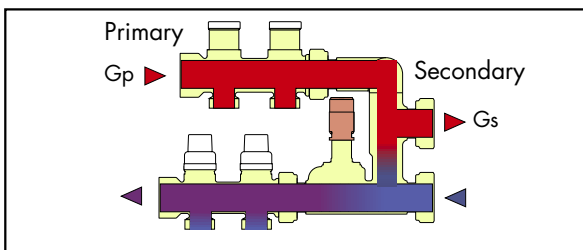

$$G_{\text{primary}} > G_{\text{secondary}}$$

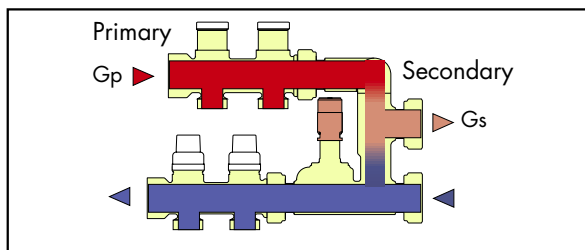

$$G_{\text{primary}} < G_{\text{secondary}}$$

Application diagram

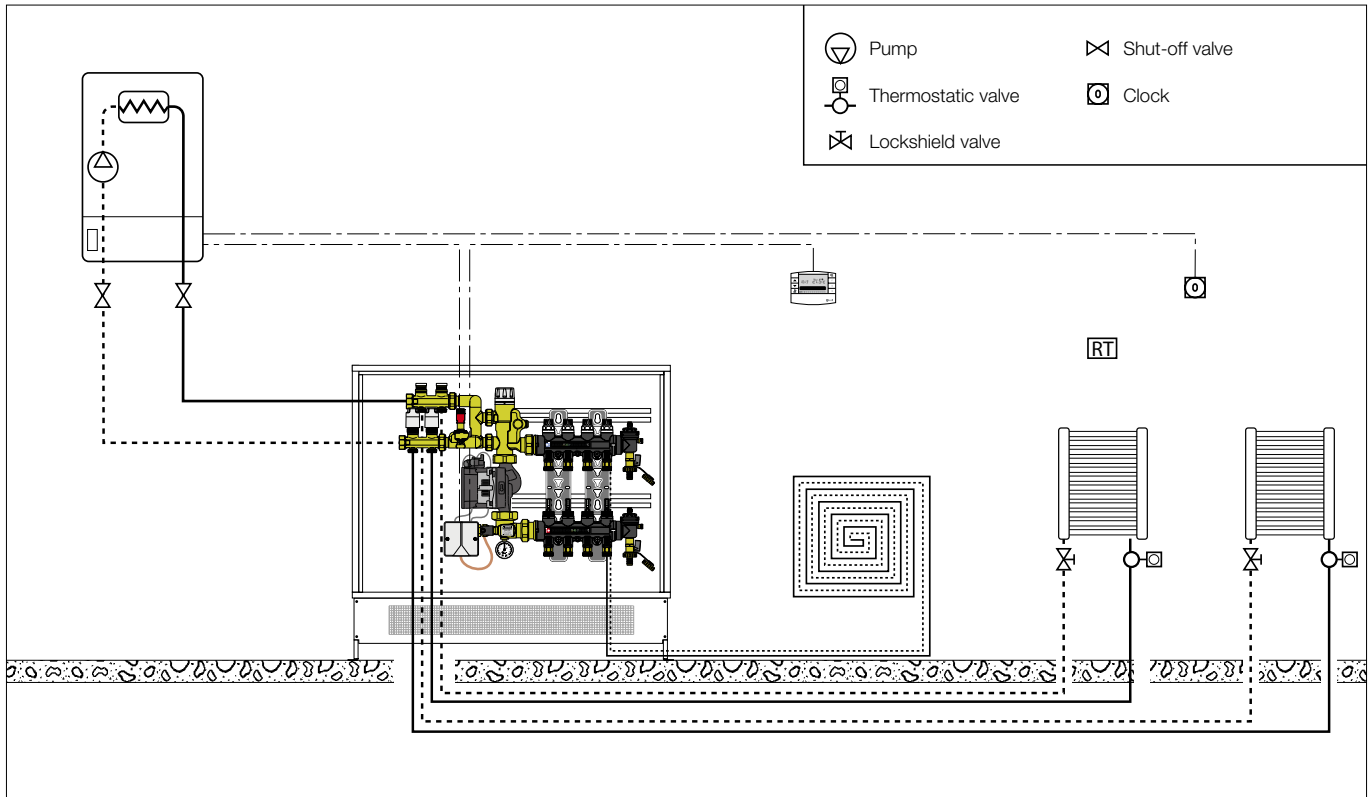

SPECIFICATION SUMMARY

182 series

Set point thermostatic regulating unit with distribution kit for primary circuit. Connections to secondary circuit 1" F (ISO 228-1). Connections to regulating unit 1" F (ISO 228-1) with nut. Panel circuit outlet connections 3/4" for coupling with adapter code 675850. Primary circuit manifold outlet connections 3/4" M - Ø 18 mm. Medium water and glycol solutions; maximum percentage of glycol 30%. Regulating temperature range 25–55°C. Maximum temperature at primary circuit inlet 90°C. Maximum working pressure: 600 kPa (6 bar). Minimum working pressure 80 kPa (0.8 bar). Panel manifold differential by-pass (optional, code 182000) setting 25 kPa. Primary circuit differential by-pass setting range 2–30 kPa (0,2–3 m w.g.). LCD thermometer scale 24–48°C. Pressure gauge scale 0–10 bar. Complete with: flow manifold for panel system with 3 outlets (from 3 to 13) with PA66GF body, flow rate regulating valve with flow meter with a scale of 1–4 l/min; return manifold for panel system with 3 outlets (from 3 to 13) with PA66GF body, shut-off valve. Regulating unit with thermostatic three-way valve with brass body and headwork, PSU obturator and EPDM seals. Flow adapter unit with brass body. Primary circuit distribution manifolds with 2 outlets, brass body and flow rate regulating and shut-off valves. By-pass kit with brass body, PA6G30 differential by-pass valve and stainless steel spring. Electric supply 230 V - 50 Hz. Safety thermostat: factory setting 55°C ± 3°C, protection class IP 55, contact rating 10 A / 240 V. Pump UPM3 Auto L 25-70, protection class IP 44.

Supplied preassembled in painted steel box. Closure with a push-fit clamp. Depth adjustable from 110 to 150 mm, including floor supports adjustable in height from 270 to 410 mm.

We reserve the right to make changes and improvements to the products and related data in this publication, at any time and without prior notice.