

Pre-adjustable pressure reducing valves with self-contained cartridge



01265/19 GB

replaces 01265/18GB

5350..H series



Function

Pressure reducing valves are devices which, when installed on a private plumbing system, reduce and stabilise the inlet pressure from the water mains. This inlet pressure, in general, is too high and variable for domestic systems to operate correctly.

The 5350..H series benefits from a pre-adjustment facility. The pressure reducing valve can be set to the desired pressure value before installation, using an adjustment knob with a pressure setting indicator. After installation, the system pressure will automatically adjust itself to the set value.

The internal self-contained cartridge containing all the adjustment components is also supplied pre-assembled to facilitate inspection and maintenance procedures.

This specific series of pressure reducing valves is certified according to the EN 1567 standard for operating with inlet water temperatures of up to 80°C.



kiwa

Product range

5350..H series Pre-adjustable pressure reducing valve with self-contained cartridge. With or without pressure gauge _____ sizes DN 15 (1/2"), DN 20 (3/4"), DN 25 (1"), DN 32 (1 1/4"), DN 40 (1 1/2") and DN 50 (2") M with union

Code 535015H/22H/28H Pre-adjustable pressure reducing valve with self-contained cartridge. Without pressure gauge _____ sizes DN 15 (Ø 15), DN 20 (Ø 22) and DN 25 (Ø 28) for copper pipe

Technical specifications

Materials

Body: dezincification resistant alloy **CR** EN 1982 CC768S
 Cover: PA6G30
 Control stem: dezincification resistant alloy **CR** EN 12164 CW724R
 Moving parts: dezincification resistant alloy **CR** EN 12164 CW724R
 Membrane: EPDM
 Seals: EPDM
 Strainer: stainless steel EN 10088-2 (AISI 304)
 Seat: (DN 15–DN 25) PPSG40
 (DN 32–DN 50) stainless steel EN 10088-3 (AISI 303)
 Cartridge: PPSG40

Performance

Max. inlet pressure: 25 bar (static, EN 1567)
 16 bar (working, EN 1567)
 Downstream pressure setting range: 1–6 bar
 Factory setting: 3 bar
 Maximum working temperature: 80°C
 Pressure gauge scale: 0–10 bar
 Strainer mesh size: (DN 15–DN 25) 0,51 mm
 (DN 32–DN 50) 0,65 mm
 Medium: water
 Compliant with standard: EN 1567
 Acoustic group: (DN 15–DN 32) II

Connections

Main connections:
 - 5350..H: 1/2"–2" M (EN 10226-1) with union
 - 535015H/22H/28H: Ø 15 - Ø 28 with compression ends for copper pipe
 Connections for pressure gauge: 1/4" F (ISO 228-1)

Dimensions

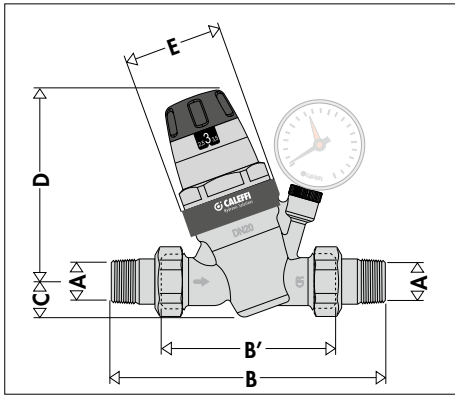

Code	DN	A	B	B'	C	D	E	Mass (kg)
53504.H	15	1/2"	140	76	20,5	115	Ø60	0,86
53505.H	20	3/4"	160	90	20,5	115	Ø60	1,02
53506.H	25	1"	180	95	20,5	115	Ø60	1,31
53507.H	32	1 1/4"	200	110	40	178	Ø78	2,78
53508.H	40	1 1/2"	220	120	40	178	Ø78	3,3
53509.H	50	2"	250	130	40	178	Ø78	4,41

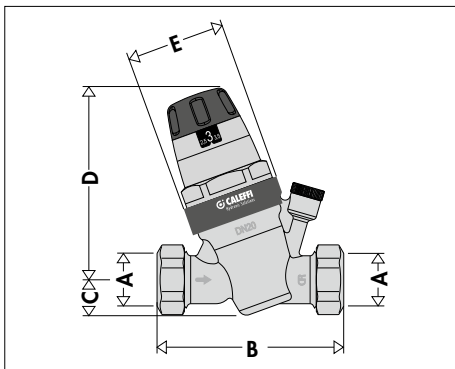

Code	DN	A	B	C	D	E	Mass (kg)
535015H	15	Ø 15	101	20,5	115	Ø 60	0,69
535022H	20	Ø 22	109	20,5	115	Ø 60	0,74
535028H	25	Ø 28	115	20,5	115	Ø 60	0,79

Operating principle

Operation of the pressure reducing valve is based on the balance between two opposing forces:

- 1 the thrust of the **spring** towards the **opening** of the obturator
- 2 the thrust of the **diaphragm** towards the **closure** of the obturator

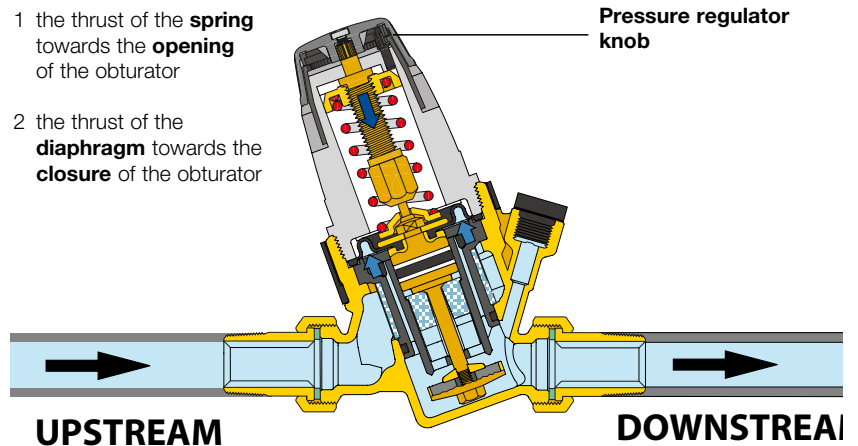

Operation with water flow

When a draw-off outlet is opened on the water system, the force of the spring becomes greater than that of the diaphragm; the obturator moves downwards opening the valve to the flow of water.

The greater the demand for water the lower the pressure under the diaphragm with a resulting greater flow of water through the valve.

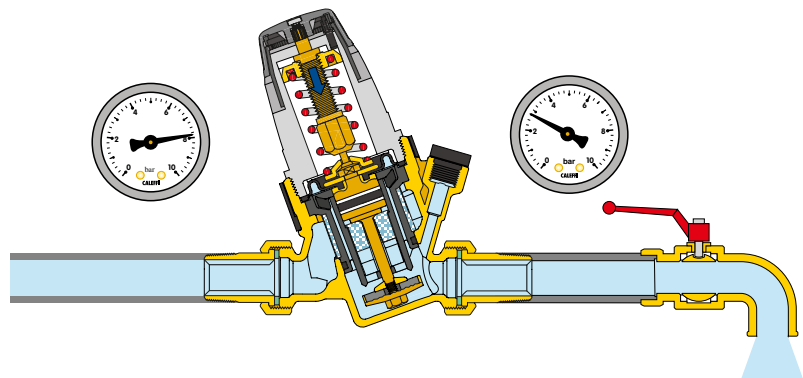

Operation without water flow

When the draw-off outlet is closed, the downstream pressure rises and pushes the diaphragm upwards.

As a result the obturator closes the valve to the passage of water and maintains the pressure constant at the calibrated pressure.

The slightest difference in favour of the force exercised by the diaphragm, in relation to that of the spring, causes the device to close.

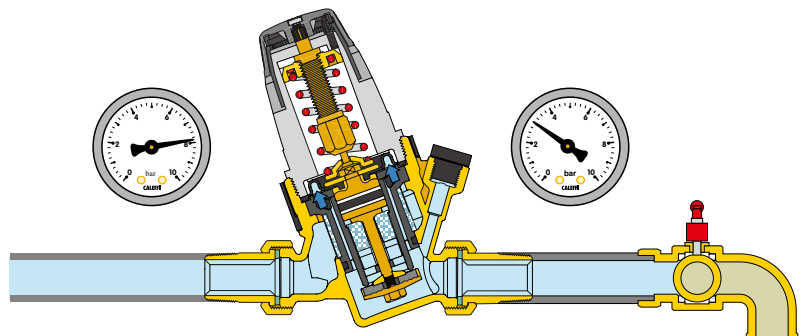

Construction details

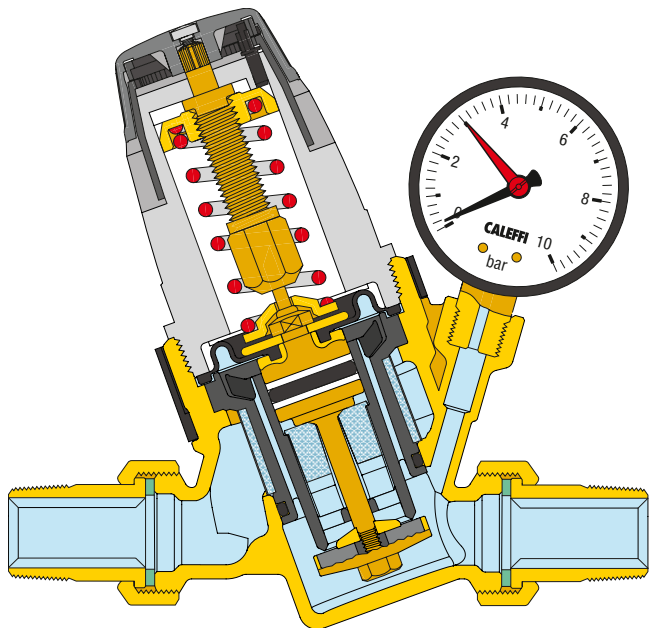

Pre-adjustment

The 5350..H pressure reducing valves are fitted with an operating knob and a pressure setting indicator which is visible on both sides. This pressure indicator features incremental step operation, therefore the pressure can be adjusted continuously with the value displayed at 0,5 bar increments.

The system pressure can therefore be pre-set to the desired value, even before the pressure reducing valve is installed.

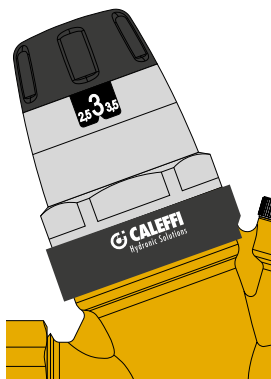

Compensated seat

Caleffi pressure reducing valves are fitted with compensated seats. This means the setting pressure value remains constant, regardless of variations in the upstream pressure value. In the figure, the thrust towards the opening is counterbalanced by the force created by the closing pressure acting on the compensating piston. Since the piston has a surface area equal to the obturator one, the two forces cancel each other out.

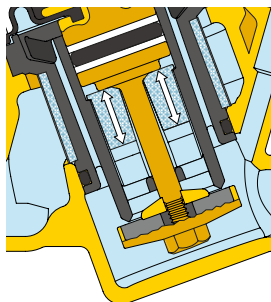

The special cross-section of the passage zone between the seat and obturator seal makes for stable behaviour in relation to upstream pressure fluctuations and operation with high flow rates, with reduced noise levels caused by the passage of water.

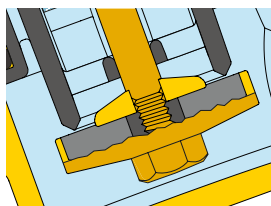

Low head losses

The internal fluid dynamic structure of the pressure reducing valve allows the achievement of very low head losses, even if a large number of consumer outlets are opened.

Working pressures

The zone exposed to upstream pressure is constructed so that it can even operate at high pressure. The PTFE anti-extrusion rings on the compensating piston make it possible for the valve to be used continuously at upstream pressures up to 16 bar.

Non-sticking materials

The central support assembly, containing moving parts, is made of plastic material with a low adherence coefficient. This solution minimises the chance of lime scale formation, the main cause of malfunctions.

Brass alloy with very low lead content (Low Lead)

The material used to make the body, stem and moving parts is designed to minimise problems associated with the use of hard and aggressive water. It also allows compliance with recent provisions relating to contact between drinking water and metallic materials.

Contoured membrane

The membrane is designed with a special shape to assure more accurate pressure regulation in accordance with downstream pressure fluctuations.

This feature also extends the life of the valve, since the diaphragm is more resistant to sudden pressure fluctuations and to normal wear.

Compact dimensions

The "inclined" configuration makes for more compact dimensions of 5350..H series pressure reducing valves with consequent easy installation, especially in domestic systems.

Removable self-contained cartridge

The cartridge containing the membrane, strainer, seat, obturator and compensation piston is a pre-assembled self-contained unit with a cover, and can be removed to facilitate inspection and maintenance procedures.

The special construction of the regulating element does not require any modification of the setting pressure value, which may be left unchanged.

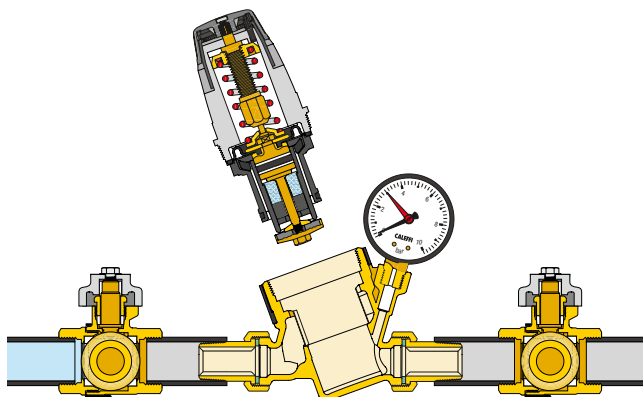

High temperatures

The materials used for the construction of this series of pressure reducing valves allow installation also on the hot water circuit with temperatures of up to 80°C.

Pressure gauge

The pressure gauge shows the exact downstream pressure value irrespective of the adjusted knob pressure setting. For special conditions, e.g. in the presence of a downstream water heater, the pressure may rise above the set value.

Certification

The 5350..H series pressure reducing valves are certified according to the EN 1567 standard for use with hot water up to 80°C. In addition, they are certified in accordance with the WRAS specifications in force in the UK.

Hydraulic characteristics

Graph 1 (Circulation speed)

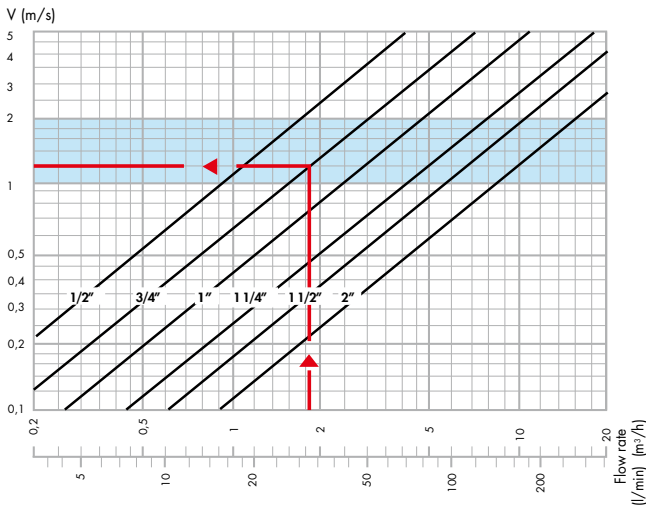

Graph 2 (Pressure drop)

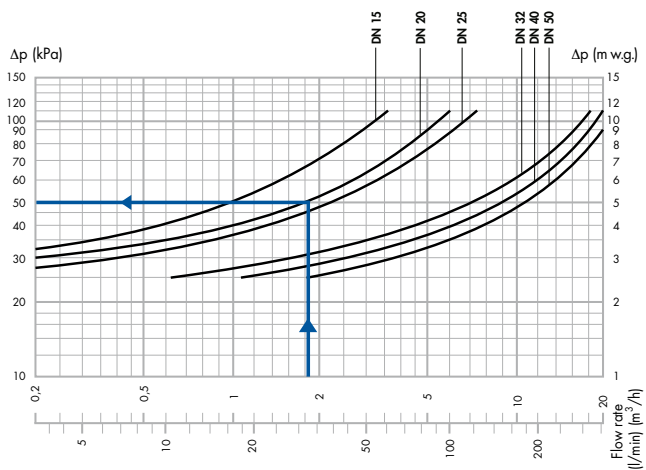

- Reference conditions: Upstream pressure = 8 bar
Downstream pressure = 3 bar

Sizing

NOTE: the criterion described below makes it possible to size the pressure reducing valves using a rapid design flow rate calculation method. For detailed sizing of the hydraulic and domestic water system with design flow rate calculation, refer to the national regulations in force.

To facilitate selection of the correct valve diameter, typical flow rates of the most common appliances used in hydraulic and domestic water systems are listed below

Table of typical flow rates

Bathtub, kitchen sink, dishwasher	12 litres/min
Shower	9 litres/min
Washbasin, bidet, washing machine, WC with cistern	6 litres/min

To prevent oversizing of the pressure reducing valve and the pipes, the correct simultaneous use correction factor must be taken into account. Basically, the more outlets within the system, the lower the percentage of draw-off outlets opened simultaneously will be.

Table of simultaneous use factors (%)

Number Appliances	Private dwelling %	Public buildings %	Number Appliances	Private dwelling %	Public buildings %	Number Appliances	Private dwelling %	Public buildings %
5	54	64,5	35	23,2	30	80	16,5	22
10	41	49,5	40	21,5	28	90	16	21,5
15	35	43,5	45	20,5	27	100	15,5	20,5
20	29	37	50	19,5	26	150	14	18,5
25	27,5	34,5	60	18	24	200	13	17,5
30	24,5	32	70	17	23	300	12,5	16,5

Correct sizing should take place as follows:

- The total flow rate is calculated from the number and type of appliances present by taking the sum of the individual flow rates.

Example:

Residence with 2 bathrooms

2 bidets	G = 12 l/min
1 shower	G = 9 l/min
2 washbasins	G = 12 l/min
2 WCs with cistern	G = 12 l/min
1 bathtub	G = 12 l/min
1 kitchen sink	G = 12 l/min
1 washing machine	G = 12 l/min

$G_{tot} = 81 \text{ l/min}$
No. of appliances = 10

- The design flow rate is calculated from the table of simultaneous use factors.

Example:

$$G_{pr} = G_{tot} \cdot \% = 81 \cdot 41 \% = 33 \text{ l/min}$$

It is recommended that flow velocity is kept within 1 to 2 metres per second when calculating the correct reducing valve size. This will prevent noise in the pipes and rapid wear of appliances.

- The correct diameter of the reducing valve is taken from diagram 1 on the basis of the design flow rate taking into account an ideal flow velocity of between 1 and 2 m/s (blue band).

Example:

for $G_{pr} = 33 \text{ l/min}$, select the 3/4" diameter (see indication on diagram 1)

- The pressure drop is taken from diagram 2 again on the basis of where the design flow rate intersects the curve for the relative diameter already selected (the downstream pressure falls by an amount equal to the pressure drop, with respect to the set pressure at no flow condition).

Example:

for $G_{pr} = 33 \text{ l/min}$ $\Delta p = 0,50 \text{ bar}$
(see indication on diagram 2)

Nominal flow rates

Water flow rates corresponding to each diameter are shown below, for an average velocity of 2 m/s, in accordance with the specifications of the standard EN 1567.

Diameter	1/2"	3/4"	1"	1 1/4"	1 1/2"	2"
Flow rate (m ³ /h)	1,27	2,27	3,6	5,8	9,1	14
Flow rate (l/min)	21,16	37,83	60	96,66	151,66	233,33



Sizing software is available on www.caleffi.com,
Apple Store and Google play.

Installation

- 1) Turn all the taps on before installing the pressure reducing valve, to flush the system and expel any air remaining in the pipes.
- 2) Install shut-off valves upstream and downstream to facilitate maintenance operations.
- 3) The pressure reducing valve may be installed on either vertical or horizontal pipe. However, it must not be installed upside down.

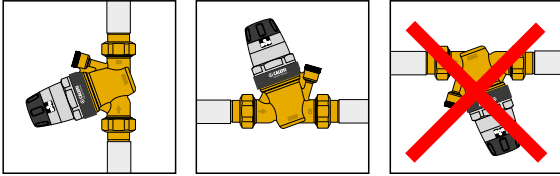

- 4) Close the downstream shut-off valve.
- 5) This mechanical pre-adjustment system, with the operating knob and pressure indicator visible from both sides, allows the pressure reducing valve to be set to the required value in the system prior to installation. The pressure indicator features incremental step movement, so that the pressure can be adjusted continuously and the value displayed at 0,5 bar increments.
- 6) Set using the operating knob on the upper part of the device. The pressure reducing valves are factory set to a pressure of 3 bar.
- 7) Given the presence of the pre-adjustment function, the presence of the downstream pressure gauge, showing the effective pressure value in the system, must be assessed in accordance with the application.
- 8) After installation, the internal mechanism will automatically control the pressure, until the set value has been reached.
- 9) Slowly reopen the downstream shut-off valve.

Installation recommendations

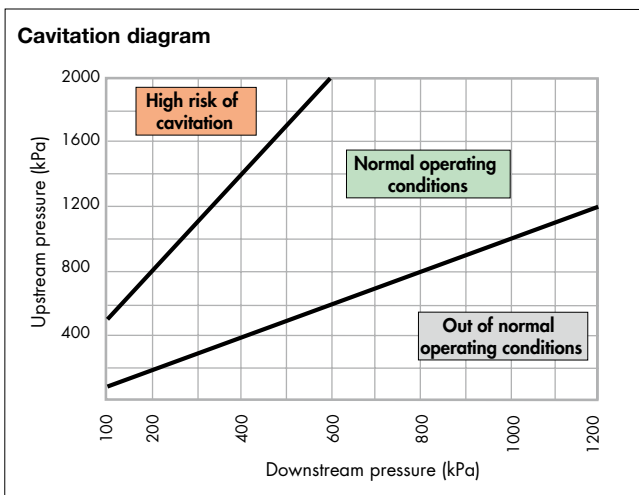

In order to minimise the risk of cavitation in the reducing valve, which could cause malfunctions with the risk of erosion in the seal area, vibration and noise, you are strongly advised to refer to the operating conditions specified in the diagram.

Due to numerous factors and variable conditions, such as: system pressure, temperature, presence of air, flow rate and speed, which could affect the performance of the pressure reducing valve; it is advisable to keep the ratio between upstream and downstream pressure ideally at 2:1 and no more than 3:1 (for example, upstream pressure 10 bar, downstream pressure 5 bar, pressure ratio = $10/5 = 2:1$) In these conditions, the risk of cavitation is minimised, but this does not preclude the possible effects of the many other factors in play in the system during operation. If the pressure ratio exceeds the specified limit, you should consider the design pressure of the system or the use of a first stage pressure reducing valve

(e.g. first stage pressure reducing valve from 16 to 8 bar and second stage from 8 to 4 bar). The upstream and downstream pipes of the pressure reducing valve must be secured with brackets in accordance with the manufacturer's instructions and local requirements, in order to avoid generating and transmitting noise and/or vibration in the installation.

1. Installation below ground

Installing pressure reducing valves below ground is not recommended, for four reasons:

- there is a risk of the reducing valve being damaged by frost
- inspection and maintenance is difficult
- reading the pressure gauge is difficult.
- impurities may enter the device through the holes designed for the release of the volumetric compression present in the casing.

2. Outdoor installation

Pressure reducing valves should not be installed outside the building unless properly protected from frost and the weather.

3. Water hammer

This is one of the main causes of faults in pressure reducing valves. It is best to fit special devices to absorb water hammer when installing pressure reducing valves in at-risk systems.

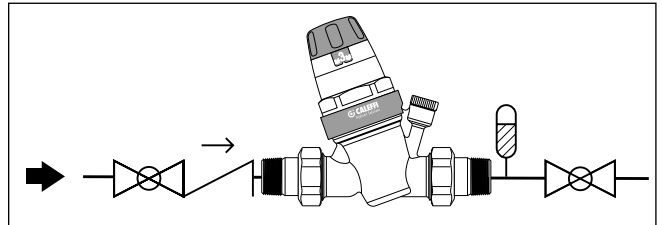

Troubleshooting

Certain types of fault, which are generally due to faulty design of the system, are often wrongly attributed to pressure reducing valves. The most frequent cases are as follows:

1. Increased downstream pressure in the presence of a water heater

This problem is due to heating of the water caused by the water heater. There is not relief of the pressure because the reducing valve is rightly closed. The solution is to install an expansion vessel (between the water heater and the pressure reducing valve) to "absorb" the pressure increase.

2. The pressure reducing valve does not maintain its setting value

In most cases this is the result of impurities that deposit on the valve seat causing leakage with a resulting increase in pressure downstream. It is advised to carry-out maintenance and cleaning of the removable cartridge (see maintenance).

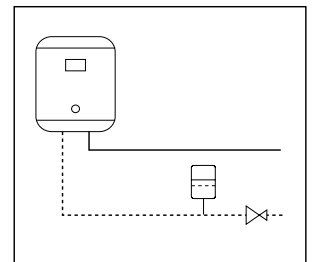

Application diagrams

Domestic water system

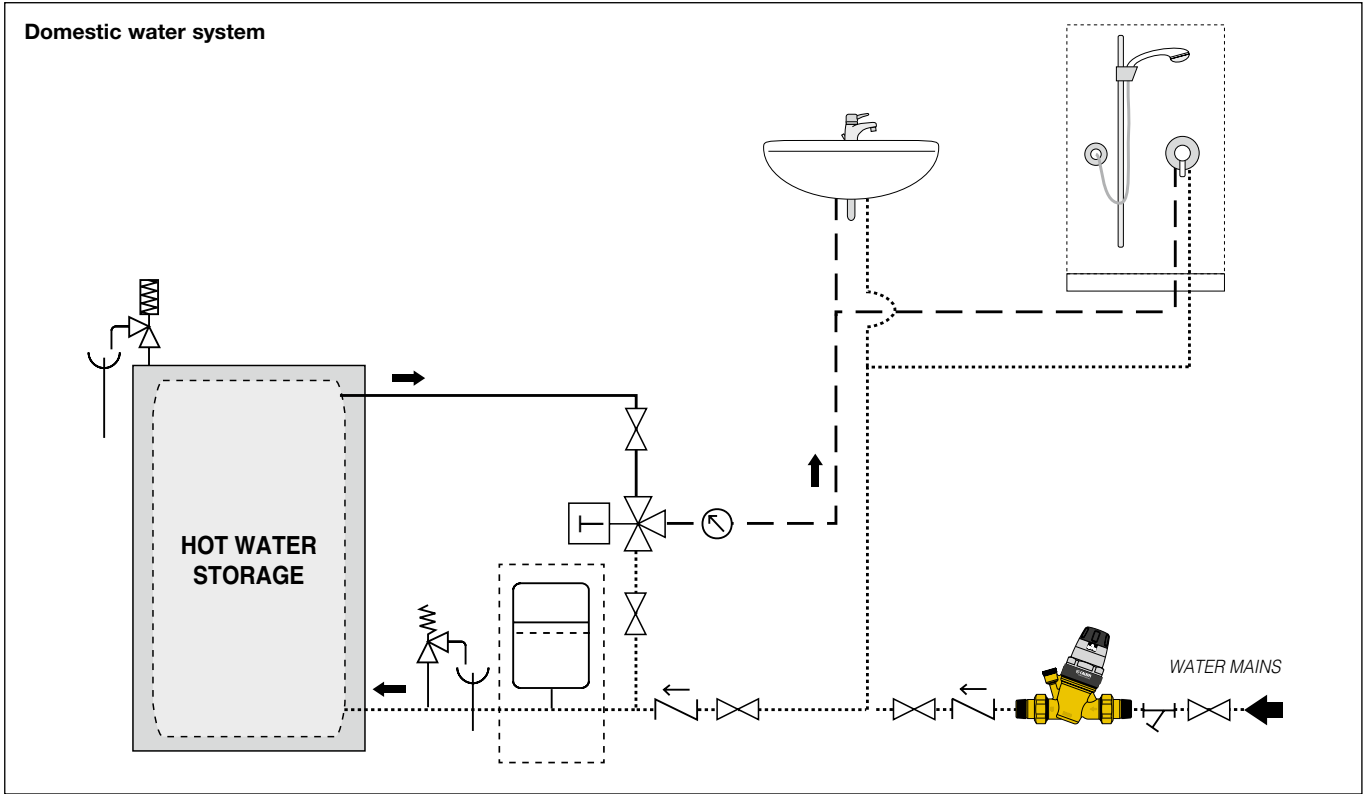

Distribution circuit with recirculation

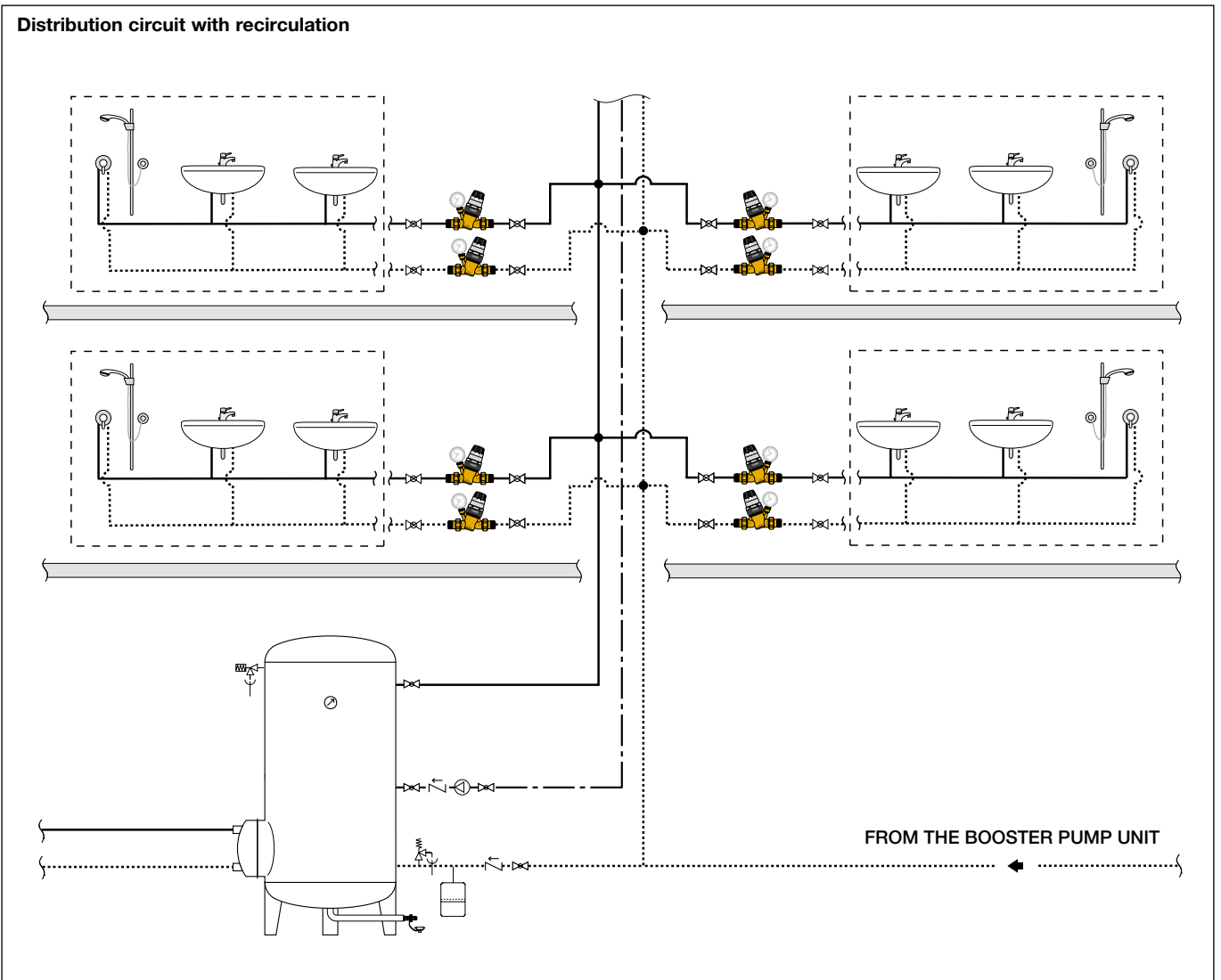

SPECIFICATION SUMMARY

5350..H series

Pre-adjustable pressure reducing valve with compensated seat and self-contained cartridge, compliant to standard EN 1567. Size DN 15 (from DN 15 to DN 50). Connections 1/2" (from 1/2" to 2") M (EN 10226-1) with union. Dezincification resistant alloy body and internal moving parts. Cover in PA6G30. Stainless steel strainer, mesh size 0,51 mm (DN 15–DN 25), 0,65 mm (DN 32–DN 50). EPDM membrane and sealing gaskets. Maximum working temperature 80°C. Max. inlet pressure 25 bar (static, EN 1567), 16 bar (working, EN 1567). Downstream pressure setting range from 1 to 6 bar. Extractable self-contained cartridge for maintenance operations. Equipped with: knob with downstream pressure adjustment scale for manual setting, pressure gauge with 0–10 bar pressure scale (version with pressure gauge). 1/4" F pressure gauge connection (version without pressure gauge).

Code 535015H/22H/28H

Pre-adjustable pressure reducing valve with compensated seat and self-contained cartridge, compliant to standard EN 1567. Size DN 15 (from DN 15 to DN 25). Ø 15 mm (from Ø 15 to Ø 28 mm) connections with compression ends for copper pipe. Dezincification resistant alloy body and internal moving parts. Cover in PA66M40/1. Stainless steel strainer, mesh size 0,51 mm. EPDM membrane and sealing gaskets. Maximum working temperature 80°C. Max. inlet pressure 25 bar (static, EN 1567), 16 bar (working, EN 1567). Downstream pressure setting range from 1 to 6 bar. Extractable self-contained cartridge for maintenance operations. Equipped with: knob with downstream pressure adjustment scale for manual setting. 1/4" F pressure gauge connection.

We reserve the right to make changes and improvements to the products and related data in this publication, at any time and without prior notice.



Caleffi S.p.A.
S.R. 229 n. 25 · 28010 Fontaneto d'Agogna (NO) · Italy
Tel. +39 0322 8491 · Fax +39 0322 863723
info@caleffi.com · www.caleffi.com
© Copyright 2019 Caleffi