

GTCL15012

Cleanline Wall Mounted Exposed Mixing Set  
(150mm Handles)



### Technical Specification

- Material: Brass
- Inlet: 15mm
- Outlet: Aerator
- Working Pressures: 50kPa - 500kPa
- Rec. Working Pressure: 350kPa
- Max Working Temp: 85°C
- Seat: Ceramic
- Finish: Chrome-plated

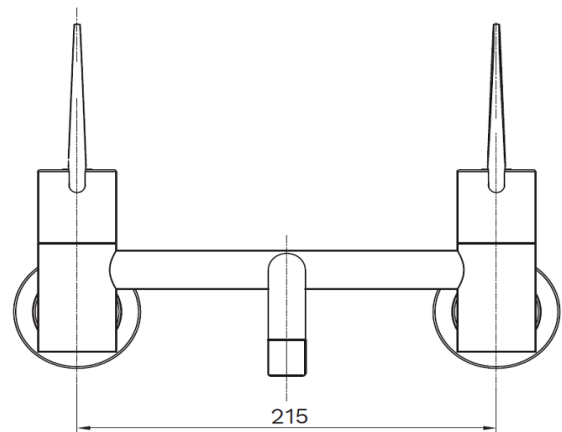
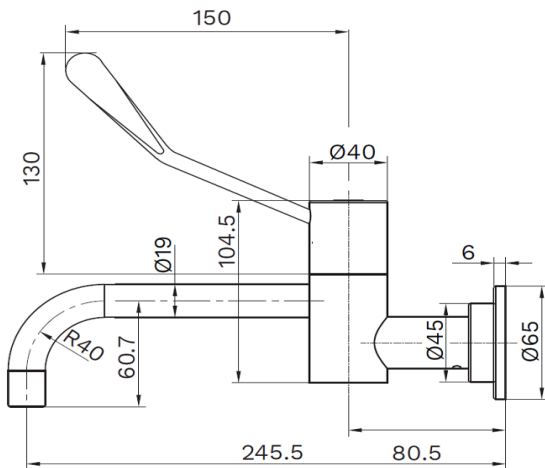

### Warranty

[Download the latest warranty statement](#)

### Features

- WELS 5 Star 5.5L/min
- Three cartridges used in all products for easy maintenance
- No crevices for bacteria build up
- Laminar flow available
- Three coloured button indicators supplied
- Soft seal on ceramic disk cartridge
- Concealed aerator
- Allen key to secure fixings for anti vandal handles and outlets
- 165mm parallel spout
- 150mm handles (100mm handles available GTCL10012)
- Recommended for use in health and aged care projects