

## Pressure reducing valves

© Copyright 2020 Caleffi

**5335..HS series**

### Installation, commissioning and servicing instructions

#### Function

Pressure reducing valves are installed in residential water systems to reduce and stabilise inlet pressure from the water mains supply which is generally too high and variable for domestic appliances to function properly. These valves can also be used to control inlet pressure to domestic hot water storage and in hot water applications.

The Caleffi 5335HS series have been specifically designed and manufactured to meet the requirements of "AS 1357.2:2005 Valves primarily for use in warm and hot water systems - P. 2: Control valves".



#### Product range



#### Series 5335..HS AUS

Pressure reducing valve  
DN 15 (1/2"), DN 20 (3/4")  
Female connections (ISO 7/1)



#### Code 533000HS

Spare part cartridge

#### Technical specifications

##### Materials:

Body:

dezincification resistant alloy **CR** EN 12165 CW602N

Cover:

PA6G30

Cartridge:

dezincification resistant alloy **CR** EN 12165 CW602N

Control piston:

dezincification resistant alloy **CR** EN 12164 CW724R

Seals:

EPDM

Strainer:

stainless steel EN 10088-2 (AISI 304)

##### Performance:

Pressure setting range:

100–600 kPa

Factory setting:

500 kPa

Max. inlet pressure:

2000 kPa

Max. working temperature:

80 °C

Medium:

water

Complies with:

AS 1357.2

## Dimensions

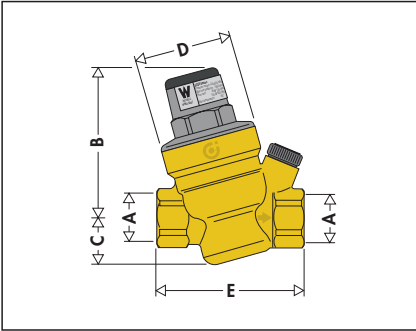

Code	DN	A	B	C	D	E	Mass (kg)
533545HS AUS	15	1/2"	74,5	22	∅ 46	79	0,50
533555HS AUS	20	3/4"	74,5	22	∅ 46	84,5	0,51

## Pressure drop diagram

Under following conditions: - Inlet pressure: 800 kPa  
- Outlet set pressure: 500 kPa

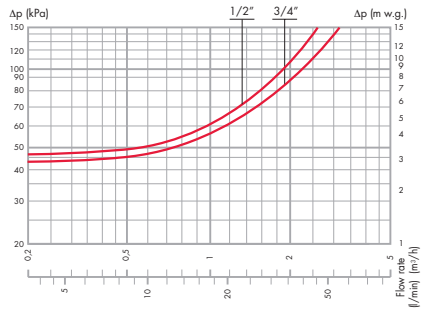

Flow rate (AS 1357.2):

DN 15	DN 20	
40 l/min	50 l/min	@ 100 kPa
100 l/min	130 l/min	@ 500 kPa
110 l/min	140 l/min	@ 600 kPa

## Installation

The pressure reducing valve must be installed by a licensed plumber and in accordance with AS/NZS 3500, relevant local requirements and following these instructions.

The installer must:

- ensure the reducing valve is compatible with any other equipment in the system it may interact with or come into contact with logistically;
- assess and acknowledge all hazards related to the use of the product, including leaks, by installing the unit properly;
- install shut-off valves fitted with pressure ports or similar equipment to measure the upstream pressure.

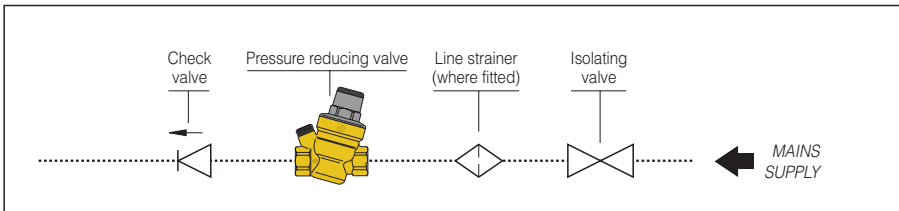

### System without recirculation

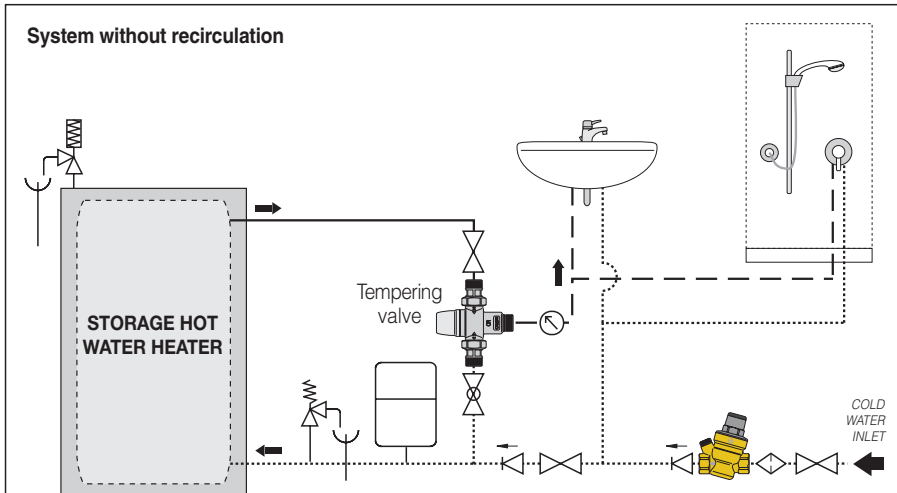

### Recommendation for installation conditions

When installed upstream of a hot water tank, we recommend installing an expansion vessel or similar equipment to absorb the increase in pressure due to the thermal expansion of the water.

When installed in large buildings, adopt technical measures such as using short pipes or including expansion valves and similar equipment to limit the increased pressure due to the thermal expansion of the water caused by temperature changes downstream of the reducing valve itself (or downstream of the first and second stage reducing valves, if two are present).

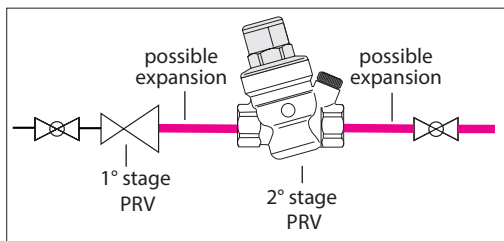
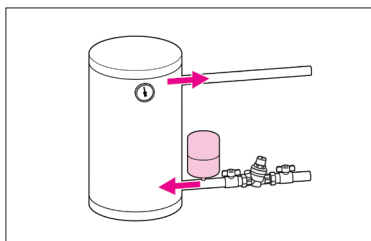

## Cavitation diagram

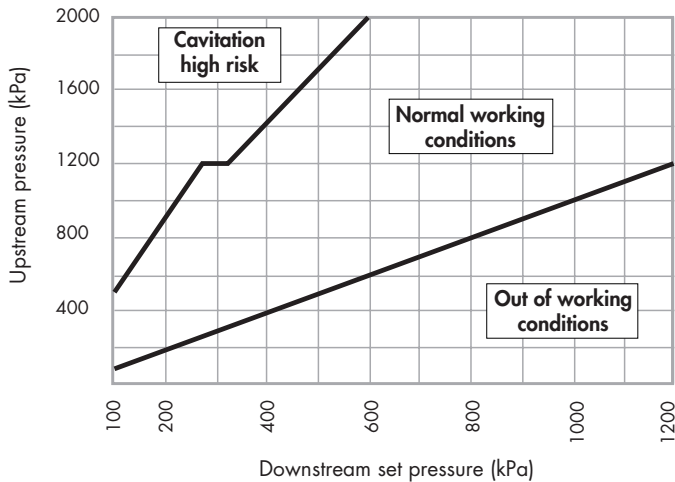

To minimize the risk of cavitation within the valve that may result in malfunctioning with erosion of valve sealing area, vibrations and noise, it is highly recommended to refer to the working conditions represented in the above diagram.

Due to the numerous factors and variable conditions experienced such as system pressure, water temperature, air presence, flow rate and velocity, which may affect the behavior of the pressure reducing valve, it is advisable that the pressure ratio between the upstream pressure and the downstream set pressure is kept ideally to a value 3:1 and no greater than a value of 4:1 (only if upstream pressure  $\leq 1200$  kPa). (For example, upstream 1200 kPa, set pressure 400 kPa, the pressure ratio =  $1200/400 = 3:1$ ). In these conditions, the possible risk of cavitation and malfunctioning is minimised, however this does not exclude the possible effects of the many other variables within the system under operating conditions.

If the pressure ratio exceeds the indicated limit, the system design pressure or use of 1st stage pressure reducing valves shall be reviewed. (For example, 1st stage reducing pressure from 2000 to 800 kPa and then 2nd stage from 800 to 300 kPa).

Pipework upstream and downstream of the pressure reducing valve shall be supported in accordance with the manufacturer's instructions, AS/NZS 3500 along with any other local authority requirements, to avoid the creation and transfer of vibration and/or noise into the installation.

The inlet strainer of the pressure reducing valve shall be periodically checked and cleaned, to minimize any partial or complete blockage which may limit the flow rate from the valve and/or create noise.

System flushing, cleaning and disinfection of the pipework to which the valve is installed shall be performed by suitably qualified persons in accordance with the system component manufacturer's instructions, AS/NZS 3500 along with any other applicable local authority requirements. Exceeding the maximum stated chemical concentrations and/or duration of exposure may negatively impact on the performance of the system and/or components installed such as the pressure reducing valve. Chemical dosed products must be chemically compatible with materials used for the construction of the pressure reducing valve, specified in its technical documentation.

### Installation below ground

If installing the 5335HS series valve underground, please ensure that steps are taken to protect the valve from becoming frozen in frost-prone areas.

Please allow yourself sufficient space to remove the cartridge should maintenance be required.

The reading of a gauge for setting purposes may be difficult and an alternate means of checking downstream pressure may be necessary.

### Water hammering

This is one of the main problems which may affect pressure reducing valves. It is best to fit special devices to absorb water hammering when fitting pressure reducing valves in systems at risk.

### WARNING:



If it is **critical** to maintain the downstream pressure setting to protect equipment, as a safety measure, we recommend that a pressure, or safety, relief valve is installed downstream of the pressure reducing valve.

### Setting

1. Flush the system.
2. Install the pressure reducing valve either vertically or horizontally, not upside down, paying attention to the "direction of flow" indicator on the body of the valve.
3. Caleffi 5335HS series pressure reducing valves are factory set at 500 kPa.
4. If required, reset the pressure by turning the screw on the top of the plastic cover. Turn it clockwise to increase the pressure and anticlockwise to decrease it.

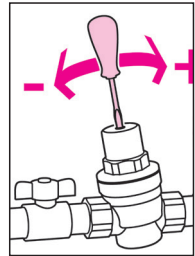

## Maintenance

The reducing valve must be checked and serviced in compliance with applicable regulations. Even when installed, commissioned and serviced properly, the reducing valve's internal components are subject to normal wear and tear, which may result in leaks and other malfunctions. We advise that you check that it is in good working order and service and clean the cartridge at least every 12 months.

Proceed as follows for periodic cleaning of the strainer and inspection of the cartridge:

- 1 Turn off upstream water supply to the pressure reducing valve and open an outlet downstream to relief pressure
- 2 Unscrew (anticlockwise) the setting screw to decompress the spring inside.
- 3 Unscrew the cover.
- 4 Extract the cartridge with the aid of pincers or screwdriver to grip the head of the screw.
- 5 After inspection and cleaning, empty the body from water and refit the cartridge or, alternatively, fit a replacement cartridge (cover tightening torque: 20–25 N·m).
- 6 Reset the valve (see *Installation*).

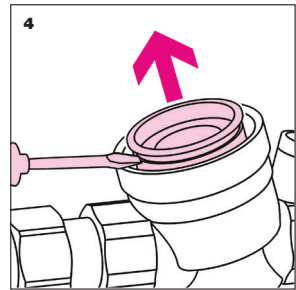
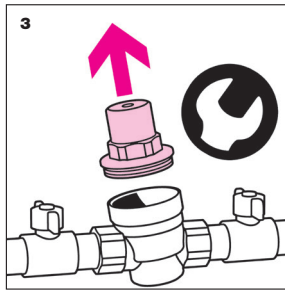
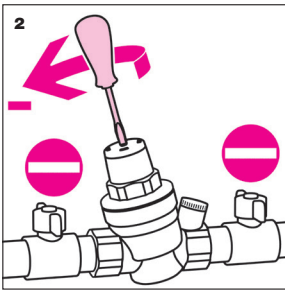

## Trouble-shooting

### 1. Increased downstream pressure near a water heater

This problem is due to the water being heated by the water heater. There is no relief of the pressure because the reducing valve is correctly closed. The solution is to install an expansion vessel (between the heater and the reducer) to “absorb” the pressure increase.

### 2. The pressure reducing valve does not maintain its set pressure

In most cases this is the result of impurities that deposit on the valve seat causing leakage with a resulting increase in pressure downstream. The solution is to fit a filter upstream from the reducer and subsequently to maintain and clean the cartridge (see *Maintenance*).

## **Safety**



If the pressure reducing valve is not installed, commissioned and maintained properly in accordance with the instructions contained in this manual, it may not operate correctly, and may cause damage to objects and/or persons.

Make sure that all the connections are water-tight.

When installing the pressure reducing valve, make sure not to over-tighten the connections to the valve as, over time, a failure can occur with subsequent water leakage causing damage.

Water temperatures higher than 50°C may cause severe burns. When installing, commissioning and maintaining the device, take the necessary precautions so that these temperatures will not endanger people.

In the case of highly aggressive water, arrangements must be made to treat the water before it enters the pressure reducing valve, in accordance with current legislation. Otherwise, the pressure reducing valve may be damaged and not function correctly.

**Leave this operating manual with the user**

***AUSTRALIAN AGENT***

**All Valve Industries**

**Unit 2, 18-28 Sir Joseph Banks Drive  
Kurnell NSW 2231**

**Ph: (02) 8543 9811**

**Fax: (02) 8543 9822**

**Email: [info@allvalve.com.au](mailto:info@allvalve.com.au)**

**CALEFFI**

S.R. 229, n. 25 · 28010 Fontaneto d'Agogna (NO) · Italy · Tel. Int. +39 322 8491 R.A. · Fax +39 322 863723  
[Http://www.caleffi.com](http://www.caleffi.com) · E-mail: [info@caleffi.com](mailto:info@caleffi.com)