

HPVMEH

Vaillant aroTHERM Plus Heat Pump Hydrobox



Technical Specification

- Rated voltage 230V (+10%/-15%), 50Hz, 1~/N/PE
- Rated voltage 400V (+10%/-15%), 50Hz, 3~/N/PE
- Rated power, maximum 8.6kW
- Rated current, maximum, 230V 2.6A
- Rated current, maximum, 400V 13.6A
- Water content 8l
- Expansion vessel 10l
- Minimum operating pressure 0.5bar
- Maximum operating pressure 3bar
- Max. heating mode flow temperature 75°C
- Min. cooling mode flow temperature 7°C
- Sound power ≤ 29dB(A)

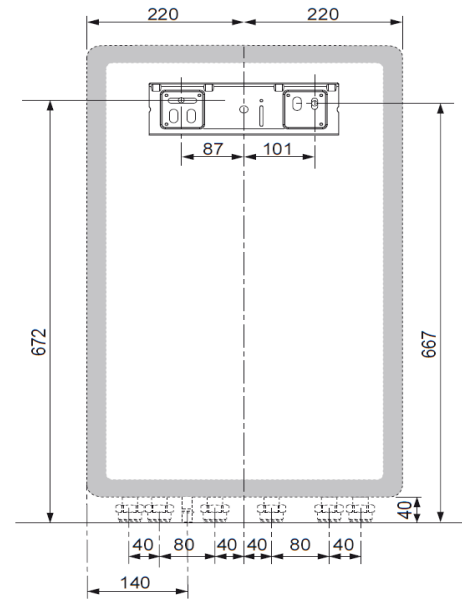
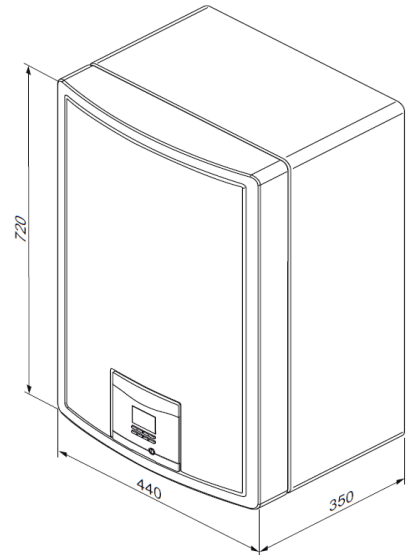

Warranty

[Download the latest warranty statement](#)

Features

Indoor hydrobox module simplifies the installation and protects vulnerable control hardware from harsh environments.

Heating, cooling and hot water installations.

3, 6 or 9kW electric backup element included

To be installed in conjunction only with HPV16 Vaillant aroTHERM Plus Heat Pump 16kW

Made in Germany