

## HEAT PUMP WATER HEATER



Installation and Operation Manual

  
WATERWARE

[waterware.co.nz](http://waterware.co.nz)



- Please keep this installation manual and read carefully before beginning the installation.
- The unit must be installed by a qualified plumber and the installation manual must be followed
- If the heat pump is to be installed in a high frost region frost protection measures must be taken, either by fitting caleffi frost protection valves or if without power the appliance must be drained of water to prevent frost damage.

## Contents

<b>Accessories Description .....</b>	<b>3</b>
<b>Safety and Installation Warnings .....</b>	<b>3</b>
<b>Heat Pump Operating Process .....</b>	<b>4</b>
<b>Installation of Unit.....</b>	<b>5</b>
<b>Installation and Product Drawings.....</b>	<b>6</b>
<b>Base Preparation and Hoisting.....</b>	<b>7</b>
<b>Pipe Connections and Guide.....</b>	<b>8</b>
<b>Water Quality .....</b>	<b>8</b>
<b>Electrical Wiring.....</b>	<b>9</b>
<b>Wiring Diagram.....</b>	<b>10</b>
<b>Controller Instructions.....</b>	<b>11</b>
<b>Fault Codes .....</b>	<b>17</b>
<b>Fault Analysis .....</b>	<b>18</b>
<b>Technical Specifications.....</b>	<b>19</b>

## Accessories Description

Each unit supplied by Waterware includes the following accessories:

No.	Name	Use
1	Installation & Operation Manual	Guide users to install the system
2	Wire Controller	Used for the man-machine operation interface
3	Wire controller connecting cable	Connect wired controller
4	Heat pump unit	For heating water

### Attention for safety

Operating range:

1. Power supply: 220V/1N~50Hz.
2. Environment temperature: -15°C ~ 43°C
3. Working water temperature: Min inlet water temperature 8°C, Max outlet water temperature 70°C

- The installation shall be carried out by professional personnel
- Confirm the ground connection, if the ground connection is not correctly done, it may cause electric shock.



### Installation Warnings

- The appliance must be installed outside in a well-ventilated location.
- Don't put finger or sticker into the air inlet or air outlet. Because the internal rotor high-speed operation may cause injury.
- If a fault occurs turn the power off to the appliance and contact a service technician.
- The appliance must be installed on a stable platform and seismically restrained via the feet.
- When cleaning the unit, the operation should be stopped, and power switch should be turned off.

## Heat Pump Operating Process

1. **Compression Stage:** The cycle begins with the low-pressure, superheated refrigerant gas in the evaporator being drawn into the compressor, where it is pressurized into high-temperature, high-pressure superheated vapor.
2. **Condensation Stage:** This vapor then flows into the condenser, where it releases heat to water circulating around it. As the refrigerant releases heat, it condenses into a high-pressure, high-temperature liquid. During this process, the water absorbs the released heat, gradually heating up.
3. **Expansion Stage:** The condensed refrigerant liquid passes through an expansion valve, where it depressurizes and cools into a low-temperature, low-pressure liquid.
4. **Evaporation Stage:** Finally, this cooled refrigerant enters the evaporator, where it absorbs energy from the surrounding air and vaporizes back into a low-pressure, superheated gas. This cycle repeats, continually transferring heat to the water flowing through the condenser, raising its temperature to produce hot water.

Air source heat pump working principle

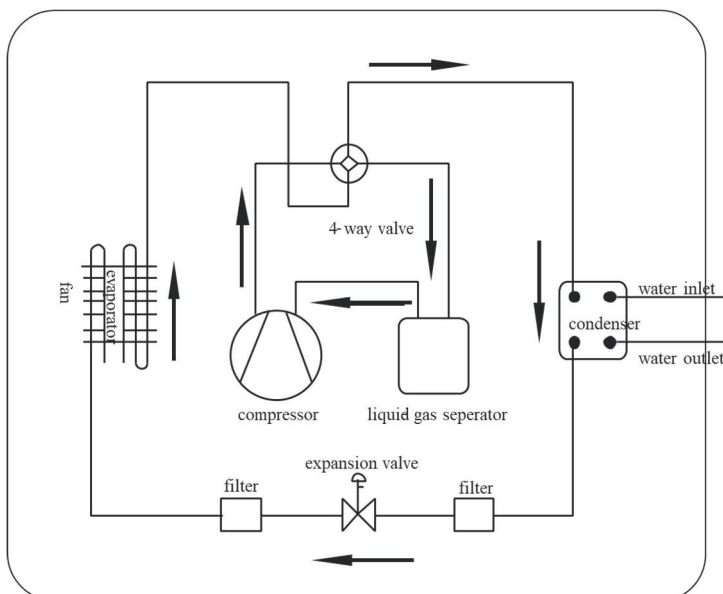

Heat pump performance curve for variable working conditions

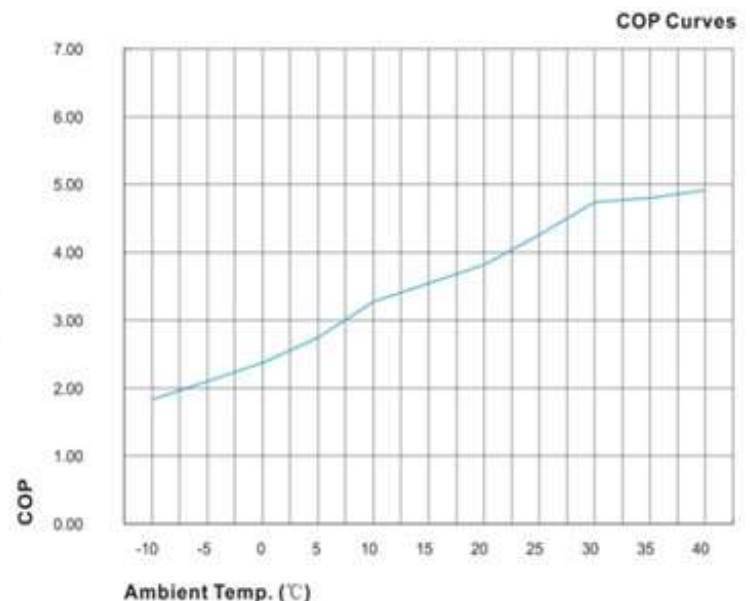

## Installation of unit

### 1. Special considerations

- The appliance must be installed in a freely ventilated space
- Avoid installations in highly corrosive environments
- Avoid installation in locations with serious power supply voltage fluctuation
- Avoid installation near flammable items.
- Avoid installation in locations with strong electromagnetic interference
- Avoid installation in locations with special harsh environmental conditions

### 2. Installation check

- Check the model to ensure it is correct for the application
- Make sure there is enough space for installation and maintenance
- Make sure barrier-free for air inlet and outlet, and is in a dry ventilated place
- Make sure the mounting location can meet the requirements of stability
- The power supply and its capacity, wire diameter choice should be in accordance with the electrical installation requirements
- Electrical installation must comply with the relevant technical standards of electrical equipment, and electrical insulation work must be done
- The unit must be powered on for at least eight hours before commissioning

### 3. Installation space

Keep the following indicated space for maintenance first before the installation

- Check there is a 1 meter space in front of the appliance for cold air discharge

## Horizontal type installation space, side air outlet (units: mm)

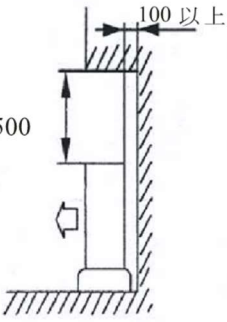
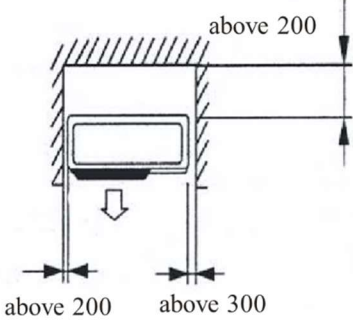
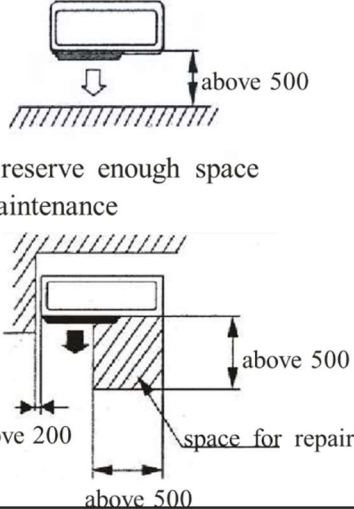
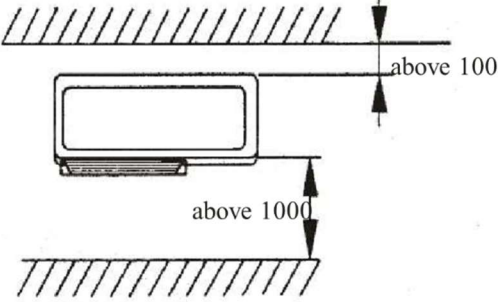
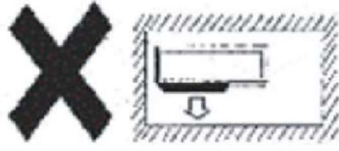
<p>1. When there are obstacles above</p> 	<p>2. air blows to the front</p> 	<p>3. front block</p> 
<p>4. front and back blocked</p> 		<p>4 sides are all blocked: can not install</p>  <p>● at least 2 sides should be open</p>

## Heat pump unit size

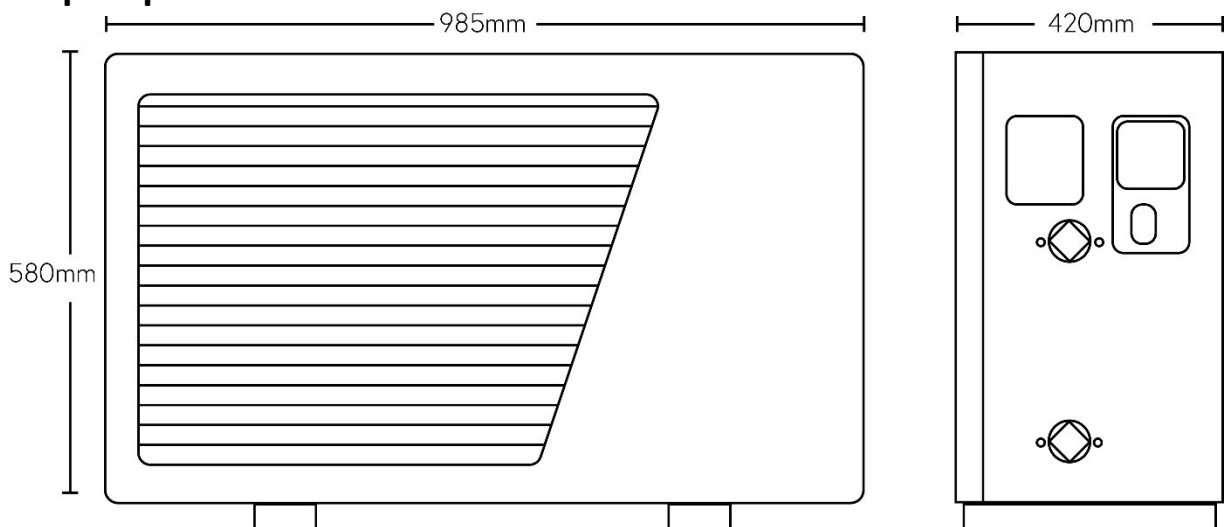

#### 4. Prepare the base for installation of the heat pump

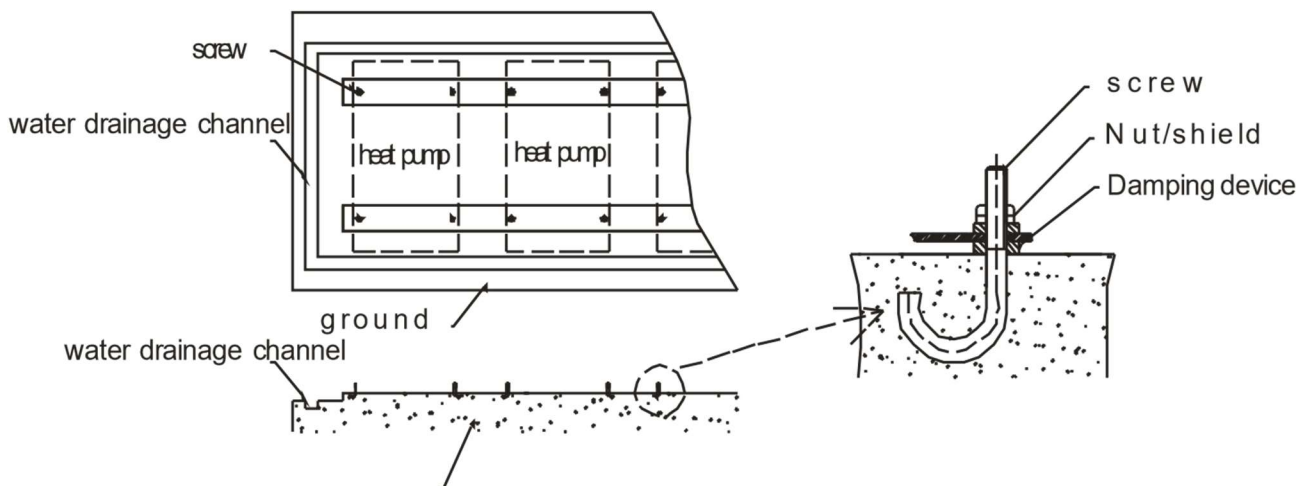

- Use lifting straps to move the appliance into position.
- Use the packing provided to prevent damage to the outside of the case
- Take special care to manage the discharge of the condensation produced during operation of the appliance
- Use noise absorbing feet to mechanically isolate the appliance from the mounting base.

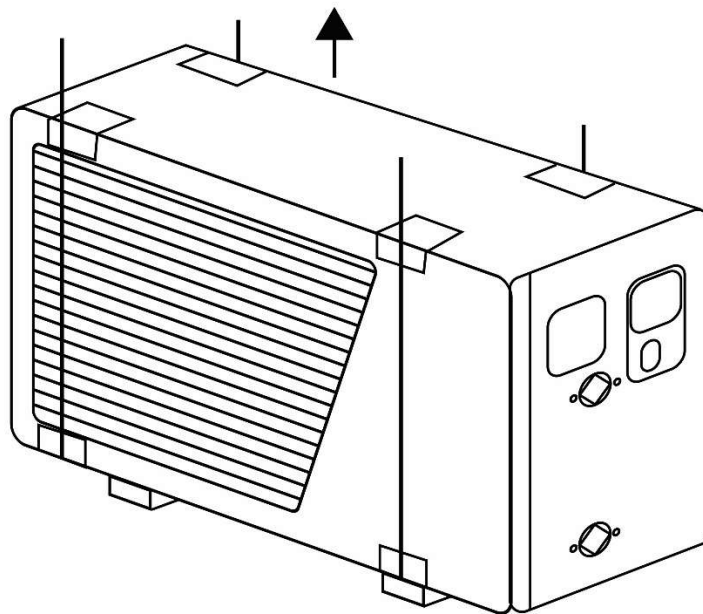



## Installation of the pipe connections

- Prevent air, dust and other dirt from going into the water pipes
- Mount the appliance before installing the water pipes
- Water inlet and outlet pipes shall be insulated, especially in high frost areas
- Do not use the water connection points to move the appliance into place, these connections can be easily damaged
- When connect the water inlet and outlet pipes, two pipe wrenches to prevent excessive torque on the thread in the appliance

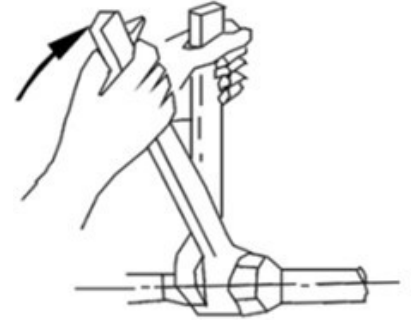

## Pipe sizing guide

- 16mm ID pipes can support up to 20m flow & 20m return systems
- 20mm ID pipes can support up to 40m flow & 40m return systems
- It is not recommended to install the appliance more than 40 meters from the hot water cylinder
- The maximum vertical distance between the appliance and cylinder is 3m

## Water quality

- Poor quality water will produce more limescale and shorten the life of the appliance, it is recommended that high limescale regions should have filtering & descaling.
- The water quality should be analysed before system running, to measure the PH value, conductivity, Chloride ion concentration and sulphate ion concentration.
- The acceptable water quality standard is showed as below table:

PH Value	Total Hardness	Conductivity	Sulphate Ion	Chlorine Ion	Ammonia Ion
7~8.5	<50ppm	<200 $\mu$ V/cm(25°C)	None	<50ppm	None
Sulfate Ion	Silicon	Iron Content	Sodium	Ca	
<50ppm	<50ppm	<0.3ppm	No requirement	<50ppm	

- A primary filter to the appliance is recommended to have a 40-micron mesh

## Electrical Wiring

- The unit should use a dedicated power supply, power supply voltage with rated voltage.
- Unit power supply circuit must be grounded, power supply wire and external grounding needs a reliable connection, and the external grounding is effective.
- Wiring must be constructed by the professional installation technicians in accordance with the circuit diagram.
- Power line and signal line layout should be neat, reasonable, can not interfere with each other, but not with the connecting pipework.
- After all wiring construction is completed, please carefully check it before switching on the power supply.
- Wiring specification: 3x2.5mm<sup>2</sup>
- Wiring diagram can be found on the next page.

## Installation Diagram

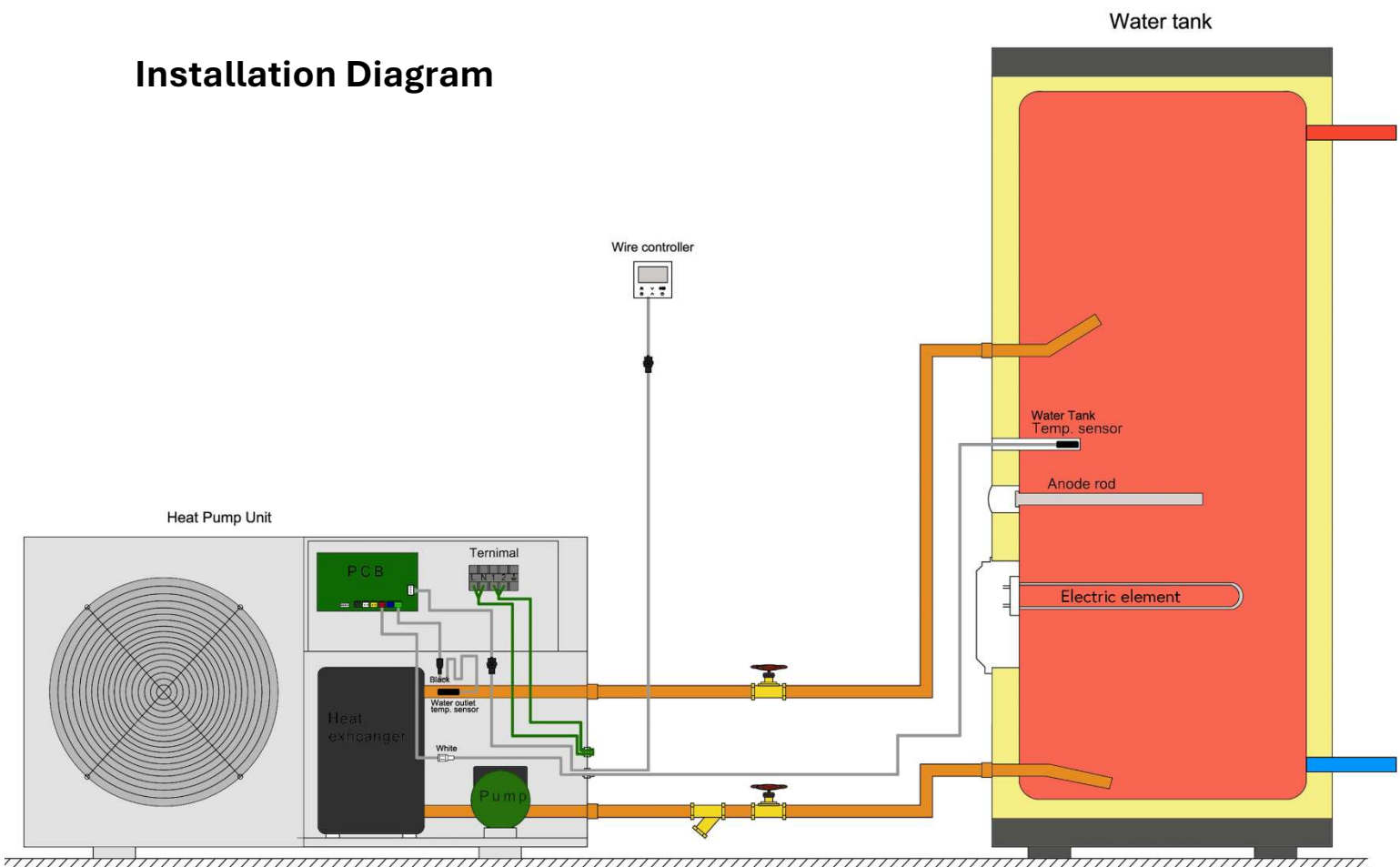

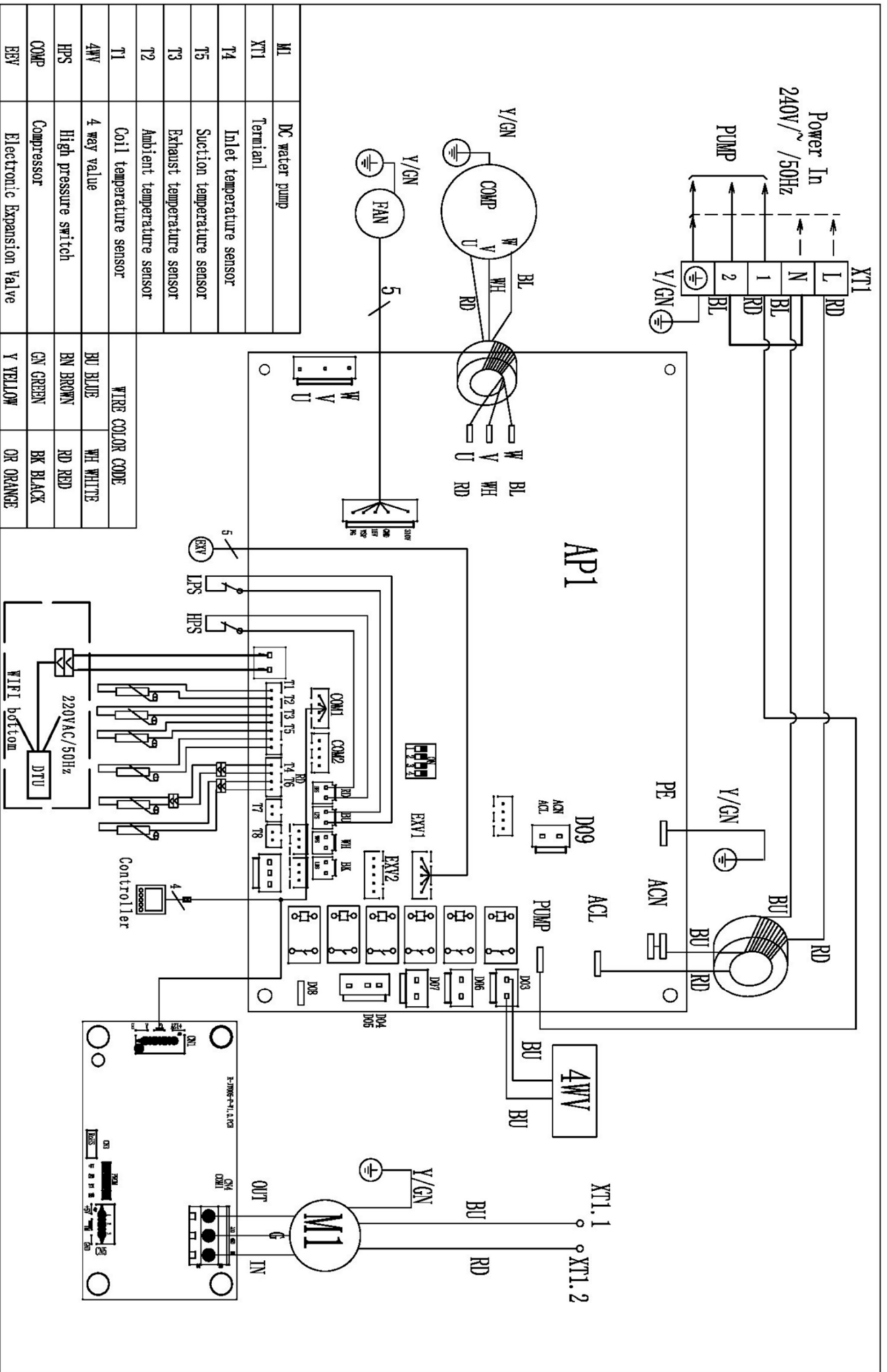

# Operation Instruction

## 1. Control Panel

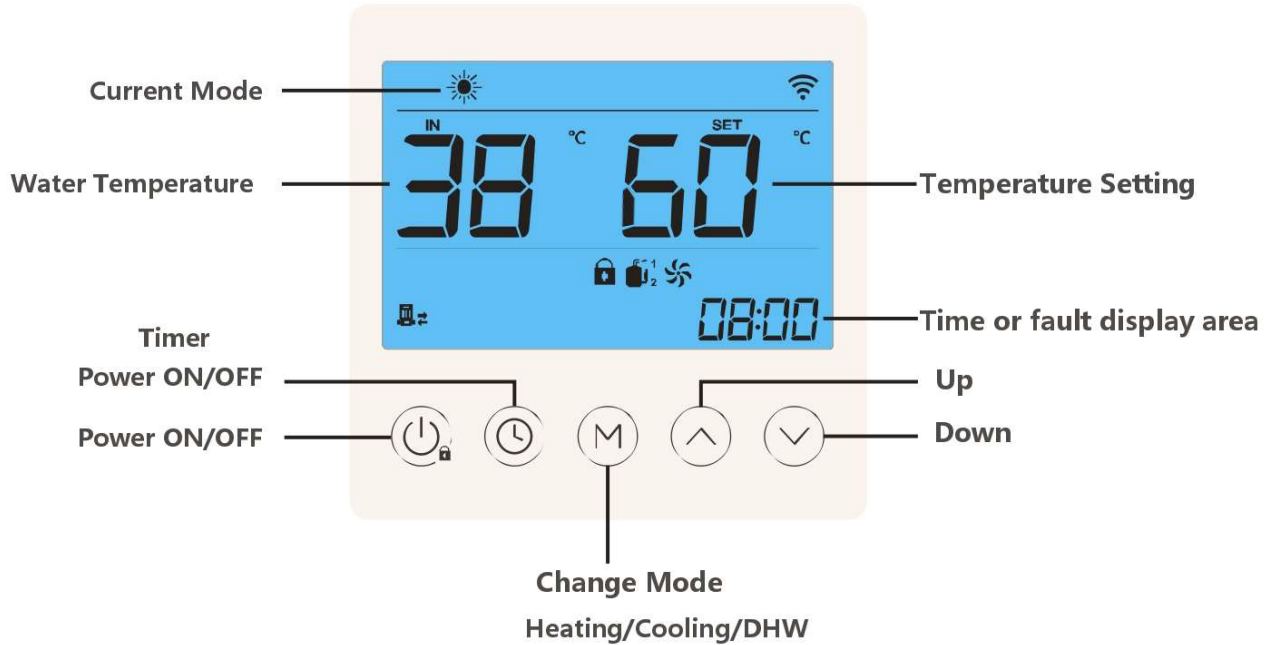

## 2. Operation Instruction

### Power On/Off

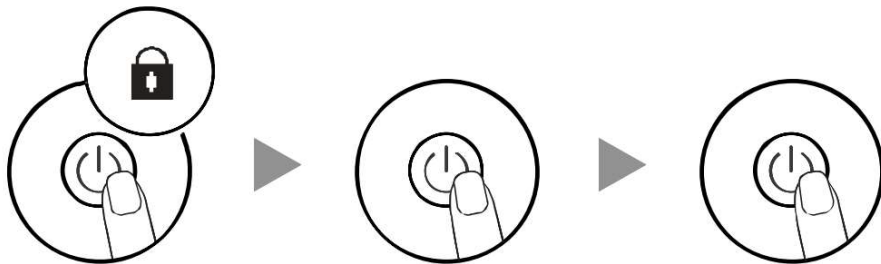

When the lock symbol is displayed, press and hold 5s to unlock the screen

Long press 2s to turn off the heat pump

Long press 2s to turn on the heat pump

### Mode Setting

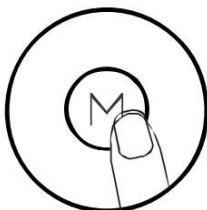

Press M to switch mode Cooling/Heating/DHW

## Temperature Setting

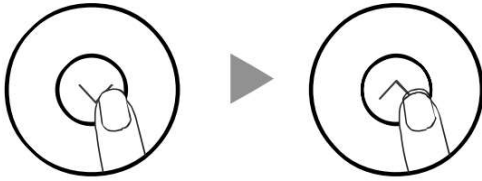

Press the up button to raise the temperature

Press the down button to lower the temperature

If there is no operation or press the on/off button within 5 seconds, the setting temperature will be saved automatically and return to the homepage

## Time Setting

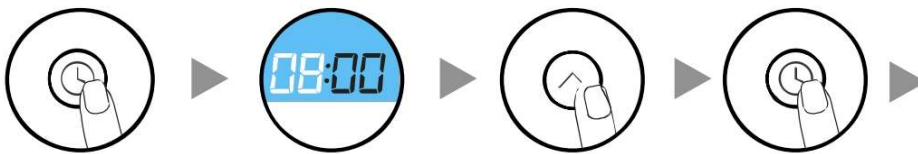

Press the clock button for 1s to enter the current clock setting

Press the clock key again, the hour area flashes

Press the up and down keys to adjust the value

Press the clock button again to enter the minute clock setting



Press the clock button again, the minute area flashes

Press the up and down keys to adjust the value

If there is no operation or press the on/off button within 5 seconds, the setting temperature will be saved automatically and return to the homepage

## Scheduled Power On



Press and hold the clock key for 5s to enter the timer boot time setting

Press the clock key again, the hour area flashes

Press the up and down keys to adjust the value

Press the clock button again to enter the minute clock setting



Press the clock button again, the minute area flashes

Press the up and down keys to adjust the value

If there is no operation or press the on/off button within 5 seconds, the setting temperature will be saved automatically and return to the homepage.

Three timings can be set.

---

### Status Search

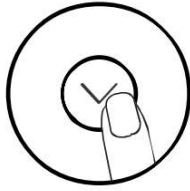

Long press the down button for 5 s to enter the status search page



Enter the status search page

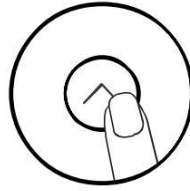

Adjust the status parameter serial number in combination with the up and down keys

### ECO Mode

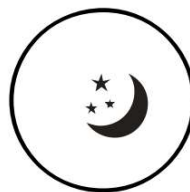
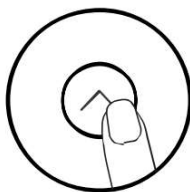
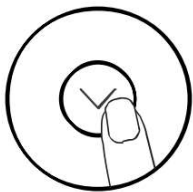

Unlock the case while holding down the up button + down button to enter ECO energy-saving mode

ECO symbol lit

### Pump forced evacuation mode

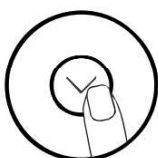
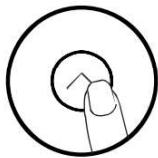

Press and hold the on/off button + up button at the same time in the unlocked state to enter the intelligent distribution mode

When the water pump symbol flashes enter forced emptying mode

---

## 4. Wi-Fi Setting

### 4.1 Software Download and Account Registration

4.1.1 Search for  Smart Life in the app store on the mobile phone, and download and install it.

4.1.2 Users who do not have an account can apply by clicking the "Create New User" function on the login page.

4.1.3 Create a new account → Enter your cell phone number or email address, → get the verification code → to enter the verification code → set the password → complete, in the following order.

4.1.4 After registration is complete, you need to create a family: create a family, → set the family name → set the location → to add a room → ultimately, in the following order.

4.1.5 Click on the device name to enter the main interface of the device

- 1) Family name, which allows access to family management.
- 2) Adding devices.
- 3) Added room; click on it to view the devices added to that room.
- 4) Room management.

---

## 4.2 Connection (Intelligent Mode)

### Manual Intelligent Distribution Network

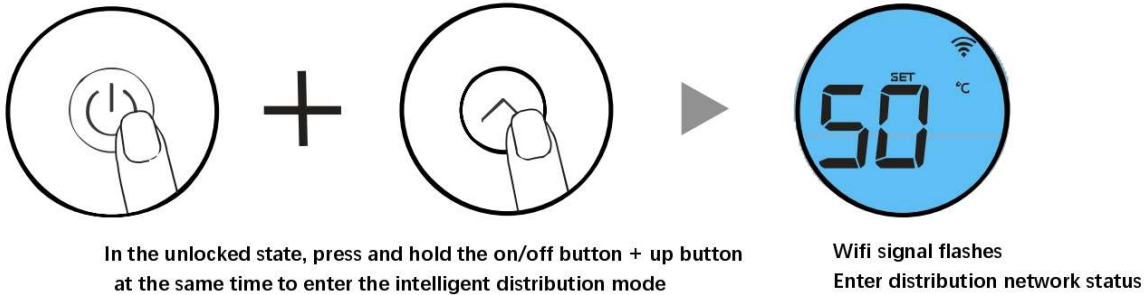

#### Step 1

Open the "Smart Life" APP, login to the main interface, click the "lift" icon in the upper right corner to add devices or "Add Device" in the interface, enter the device type selection, and select "Smart Heat Pump (Wi-Fi)" in the "Main Appliance" device, enter the add device interface.

#### Step 2

Select Smart Heat Pump (Wi-Fi) and enter into the Wi-Fi connection interface, enter the Wi-Fi password that the phone has been connected to (must be the same as the Wi-Fi connection to the phone), click Next, and confirm that the line controller has selected the intelligent distribution mode, " " icon  fast-flashing, click "Confirm that the indicator is flashing, then start adding devices directly, click the "lift" icon to add devices.

Note: The icon flashes slowly when the Wi-Fi module is connected to the Wi-Fi hotspot.

#### Step 3

The system prompts "Add Device Successfully" and then the network is successfully distributed. Click on the icon in this interface to change the device name, select the device installation location (living room, main bedroom), and click Finish to enter the main interface of device operation.

## 4.3 Connection (AP Mode)

### Manual AP Distribution Network

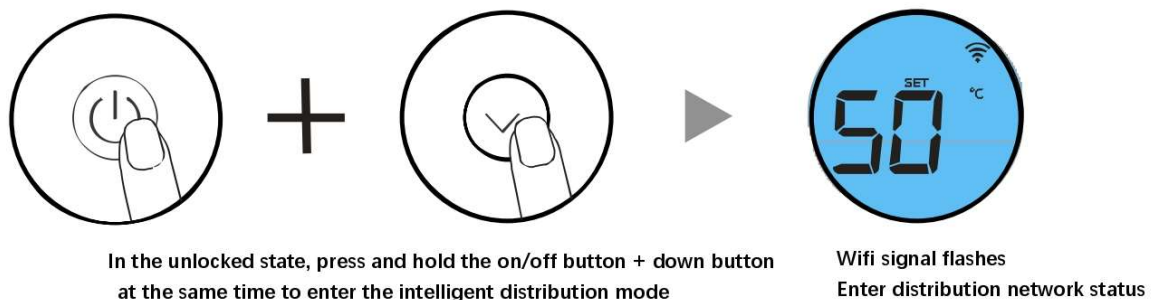

**Step 1 and Step 2:** Be consistent with the Intelligent Mode

#### Step 3

Select innovative heat pump (Wi-Fi) after entering into the Wi-Fi connection interface, enter the phone has been connected to the (Wi-Fi) password (must be consistent with the Wi-Fi connection



---

to the phone), click next, confirm that the line controller has selected AP distribution mode, an icon in the slow flashing state “ ”, click "Confirm that the indicator is in slow flashing," then connect the phone Wi-Fi to the device hotspot (as shown below), confirm that the connection hotspot is correct to continue to the next step then directly begin to connect the device interface, find the device → registers to the cloud → device initialization is complete.

Note: When the wire Wi-Fi module is connected to the Wi-Fi hotspot, the icon “ ” slo  flashing.

#### **Step 4** The same as the Intelligent Mode

Note: If the connection fails, manually enter the AP network configuration mode again and repeat the preceding steps to connect again.

### **4.4 Software Function Operation**

4.4.1 A device is automatically bound to a virtual gateway. The "My Home Heat Pump" (device name, which can be changed) operation page is displayed.

Buy a ticket to enter the device operation page of "My Home Heat Pump" by clicking on "My Home Heat Pump" in the "All Devices" screen of smart Life.

4.4.2 Modify device name and modify device location information Click "Name" to rename the device name and "Location" to alter the device location.

### **4.5 Device Sharing**

Share bound devices in the following sequence:

- 1) After successful sharing, the list is added to display the shared person.
- 2) To delete the shared user, long-press the selected user, and the deletion interface will pop up, click "Delete"
- 3) User interface operations are as follows:
- 4) Enter the account of the shared user and click "Finish" to display the newly shared history in the list of successful sharing
- 5) The interface of the shared person is as follows. The shared device received is displayed. Click in to operate and control the device.

### Error Code Table

<b>Fault Code</b>	<b>Fault Description</b>
E03	Heat Pump Machine Water flow switch failure
E05	Refrigerant System High Pressure switch protection
E06	Refrigerant System Low Pressure switch protection
E09	Communication failure between the wire controller and the main board
E11	Heat Pump unit water temp over low protection (alarm)
E12	Exhaust temperature is too high
E15	Water Inlet Temp Sensor failure
E16	Coil sensor failure
E18	Exhaust gas sensor failure
E21	Outdoor Ambient temp. sensor failure
E27	Heat pump Hot water outlet temp. sensor failure
E29	Return air sensor failure
E38	Fan Motor Failure
E88	Inverter Board Protection
E96	Between Compressor and PCB communication failure
E98	Between Fan Motor and PCB communication failure

## Operation Parameter Query

Query Code	Description	Range
1	Compressor Running Frequency	0 ~ 150 Hz
2	Fan Motor Running Frequency	0 ~ 999 Hz
3	Electronic expansion valve steps	0 ~ 480 P
4	EVI valve steps	0 ~ 480 P
5	AC Input Voltage	0 ~ 500 V
6	AC Input Current	0 ~ 50 A
7	Compressor Phase Current	0 ~ 50 A
8	IPM temperature of the compressor	-40 ~ 140 °C
9	High-pressure saturation temperature	-50 ~ 200 °C
10	Low-pressure saturation temperature	-50 ~ 200 °C
11	External ambient temperature T1	-40 ~ 140 °C
12	Outer coil (fin) T2	-40 ~ 140 °C
13	Internal coil (plate heat exchanger) T3	-40 ~ 140 °C
14	Gas Suction Temperature T4	-40 ~ 140 °C
15	Gas Exhaust Temperature T5	0 ~ 150 °C
16	Water Inlet Temperature T6	-40 ~ 140 °C
17	Water Outlet Temperature T7	-40 ~ 140 °C
18	Economizer Inlet Temperature T8	-40 ~ 140 °C
19	Economizer Outlet Temperature T9	-40 ~ 140 °C
20	Machine Tooling No.	0 ~ 120
21	Water tank temperature	-40 ~ 140 °C
22	Fluorine plate heat exchanger out temperature	-40 ~ 140 °C
23	Driver manufacturers	0 ~ 10
24	Water pump speed PWM	0 ~ 100%
25	Water flow	3 ~ 100 L/min
26	Return water temperature	-40 ~ 140 °C
27	Unit input voltage	0 ~ 500 V
28	Unit input current	0A ~ 99.99A
29	Unit input power	0 ~ 99.99KW
30	Total electricity consumption of the unit	0 ~ 9999 Kw.h

**Display Fault:** When the machine has a fault, the fault is flashing in the timing area and the fault code is displayed cyclically; when the fault is eliminated, the standard display is restored.

## Fault Analysis

Fault	Possible cause	Detection and elimination method
Discharge pressure is too high.	<ul style="list-style-type: none"> <li>◆ There is air or other non-condensable gas existed in the system.</li> <li>◆ Water heat exchanger is scaling or fouling blockage.</li> <li>◆ The circulation water volume is not enough.</li> <li>◆ Refrigerant charging is too much.</li> </ul>	<ul style="list-style-type: none"> <li>● Vent the air from water heat exchanger</li> <li>● Wash and clean the water heat exchanger</li> <li>● Examine the water system pipeline and pump.</li> <li>● Drain part of the refrigerant</li> </ul>
Discharge pressure is too low.	<ul style="list-style-type: none"> <li>◆ Liquid refrigerant flow through evaporator to compressor, which make foam for the frozen oil</li> <li>◆ Suction pressure is too low</li> <li>◆ Refrigerant charging is too less, the refrigerant air goes into liquid pipeline</li> </ul>	<ul style="list-style-type: none"> <li>● Examine and adjust the expansion valve, make sure the expansion valve temperature sensor bulb is close connected with the air suction pipe, and absolutely insulated with the ambient environment.</li> <li>● Please refer to "Fluorine filling if suction pressure too low"</li> </ul>
Suction pressure is too high.	<ul style="list-style-type: none"> <li>◆ Discharge pressure is too high.</li> <li>◆ Refrigerant charging is too much.</li> <li>◆ Liquid refrigerant flow through evaporator to compressor.</li> </ul>	<ul style="list-style-type: none"> <li>● Drain part of the refrigerant.</li> <li>● Examine and adjust the expansion valve, make sure the expansion valve temperature sensor bulb is close connected with the air suction pipe, and absolutely insulated with the ambient environment.</li> </ul>
Suction pressure is too low.	<ul style="list-style-type: none"> <li>◆ Ambient temperature is too low.</li> <li>◆ The evaporator liquid inlet or compressor suction pipe is blocked, expansion valve unadjusted, or failed.</li> <li>◆ The refrigerant is not enough in the system.</li> </ul>	<ul style="list-style-type: none"> <li>● Adjust suitable overheat temperature, examine whether there is Fluorine leakage from the expansion valve temperature sensor bulb.</li> <li>● Examine Fluorine leakage.</li> <li>● Examine the installation condition.</li> </ul>
Compressor stopped because of high pressure protection.	<ul style="list-style-type: none"> <li>◆ The water inlet temperature is too high, circulation water is not enough.</li> <li>◆ The high pressure stop setting is not correct, the air suction overheat greatly.</li> <li>◆ Fluorine filling is too much.</li> </ul>	<ul style="list-style-type: none"> <li>● Examine water system pipeline and water pump.</li> <li>● Examine the high pressure switch.</li> <li>● Examine the Fluorine filling volume, drain part of refrigerant.</li> </ul>
Compressor stopped because of motor overloading.	<ul style="list-style-type: none"> <li>◆ The voltage is too high or too low.</li> <li>◆ Discharge pressure is too high or too low.</li> <li>◆ Device loading failure.</li> <li>◆ Ambient temperature is too high.</li> <li>◆ Motor or connecting terminal is in short circuit.</li> </ul>	<ul style="list-style-type: none"> <li>● The voltage should be controlled within more or less 20V than rated voltage, and phase difference within <math>\pm 30\%</math>.</li> <li>● Examine the compressor current, compare with the full loading current indicated in the user manual.</li> <li>● Improve air ventilation.</li> </ul>
Compressor stopped because of built-in thermostat.	<ul style="list-style-type: none"> <li>◆ The voltage is too high or too low.</li> <li>◆ Discharge pressure is too high.</li> <li>◆ The refrigerant in the system is not enough.</li> </ul>	<ul style="list-style-type: none"> <li>● Examine the voltage to make sure it is within the specialized range.</li> <li>● Examine the discharge pressure and find out the reason.</li> <li>● Examine whether there is Fluorine leakage.</li> </ul>
Compressor stopped because of low voltage production	<ul style="list-style-type: none"> <li>◆ Dry filter clogging.</li> <li>◆ Expansion valve failure.</li> <li>◆ The refrigerant is not enough.</li> </ul>	<ul style="list-style-type: none"> <li>● Examine, maintain, or change dry filter.</li> <li>● Adjust or change expansion valve.</li> <li>● Fill in refrigerant.</li> </ul>
High noise of compressor	<ul style="list-style-type: none"> <li>◆ There is liquid hammer for liquid refrigerant flowing through evaporator to compressor.</li> </ul>	<ul style="list-style-type: none"> <li>● Adjust liquid supply, examine whether normal for the expansion valve and air suction over heat degree.</li> </ul>
Compressor can not start.	<ul style="list-style-type: none"> <li>◆ Over current relay is tripped, insurance is burn.</li> <li>◆ The control circuit is not connected.</li> <li>◆ No current.</li> <li>◆ The pressure is too low, which can not conduct the pressure switch.</li> <li>◆ The contactor coil is burn out.</li> <li>◆ Water system failure, relay is tripped.</li> </ul>	<ul style="list-style-type: none"> <li>● Set the control circuit in manul mode, restart the compressor after maintenance.</li> <li>● Examine controlling system.</li> <li>● Examine power supply.</li> <li>● Examine whether the refrigerant is too less.</li> <li>● Reconnect, adjust two of the wiring.</li> </ul>

<b>Technical specifications</b>	
<b>Model No.</b>	<b>HPRPD5</b>
<b>Power Supply</b>	<b>220V/50Hz</b>
<b>Heating Capacity at Air 20°C/15°C, Water Temperature from 15°C to 55°C</b>	
<b>Heating Capacity(kW)</b>	<b>5.25</b>
<b>Power Input(kW)</b>	<b>0.933</b>
<b>COP</b>	<b>5.25</b>
<b>Max Power Input (kW)</b>	<b>1.5</b>
<b>Max Current(A)</b>	<b>6.7</b>
<b>Rated Hot Water(L/h)</b>	<b>105</b>
<b>Expansion Valve</b>	<b>Electronic</b>
<b>Air Flow Direction</b>	<b>Horizontal</b>
<b>Water Pump inside</b>	<b>Yes</b>
<b>Water Pressure Drop(kPa)</b>	<b>35</b>
<b>Net Dimensions(L*W*H) (mm)</b>	<b>990×438×655</b>
<b>Package Dimensions(L*W*H)(mm)</b>	<b>1040*468*670</b>
<b>Working temperature range(°C)</b>	<b>-15~43</b>
<b>Noise(dB)</b>	<b>49</b>
<b>Net Weight(kg)</b>	<b>60</b>
<b>Water connection(mm)</b>	<b>female 20</b>

# HPRPD5 SUITABLE CONFIGURATIONS

## SOLAR DIRECT

Use direct auxiliary ports

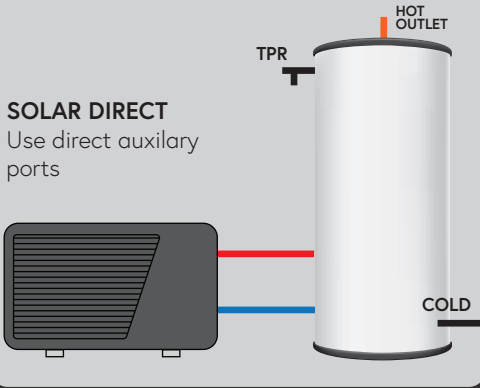

## DUAL ENTRY

Use spare cold port on opposite side

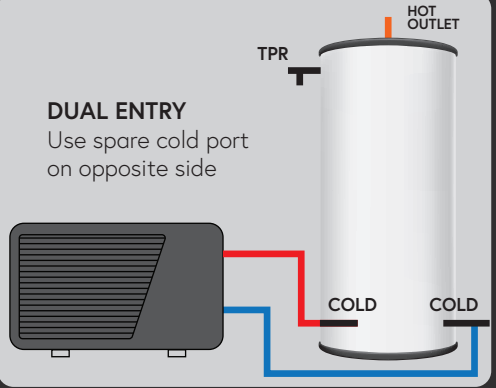

## CONVENTIONAL/ PROTANK

Tee across cold & TPR valve port

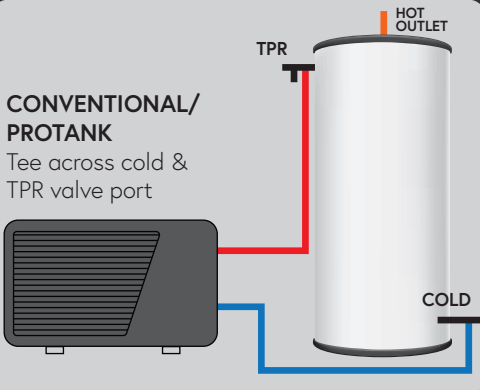

## OLD HWC

Not recommended

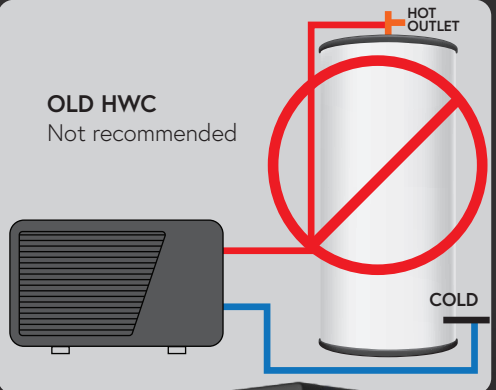

To ensure the Ritter hot water heat pump operates at peak efficiency, we are providing the correct configurations for connecting to hot water cylinders.

This quick guide helps to understand the optimal setup, ensuring seamless integration and reliable performance.

Getting it right the first time and delivering the best results for your customers!



# QUICK GUIDE

## HPRPD5 Dual entry cylinder configuration

The following guide, shows the recommended method in configuring the HPRPD5 Ritter R290 Hotwater heatpump to a standard hot water cylinder, with LH and RH cold water inlets.

### Creating Probe Pocket

1

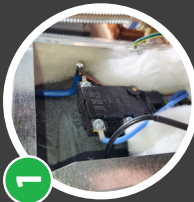

**Recommended method to mount the DHW probe:**  
Use a 6mm allen key to create a well against the inside skin of the cylinder.

2



Push the allen key up to create a well 75mm long, vertically above the element housing.

3

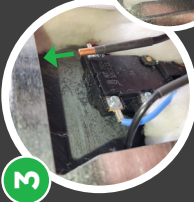

Thread the DHW probe through the cable gland and push into the well.  
Replace insulation wool.



### KEY

1. Ritter R290 heatpump unit
2. Heat exchanger
3. Pump
4. Controller
5. Terminal Connections
6. Hotwater Outlet
7. Probe Pocket
8. Electric Element
9. Probe - supplied in unit
10. Cold Water Inlet
11. Heat Pump Return
12. Heat Pump Flow

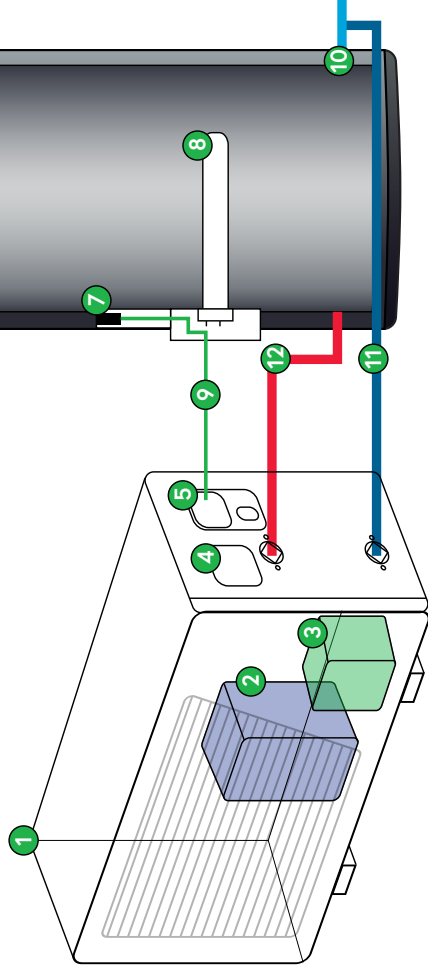

# QUICK GUIDE

## HPRPD5 Solar direct cylinder configuration

The following guide, shows the recommended method in configuring the HPRPD5 Ritter R290 Hotwater heatpump to a standard solar hot water cylinder.

### KEY

1. Ritter R290 heatpump unit
2. Heat exchanger
3. Pump
4. Controller
5. Terminal Connections
6. Hotwater Outlet
7. Anode Rod
8. Electric Element
9. Probe - supplied in unit
10. Cold Water Inlet
11. Heat Pump Return
12. Heat Pump Flow

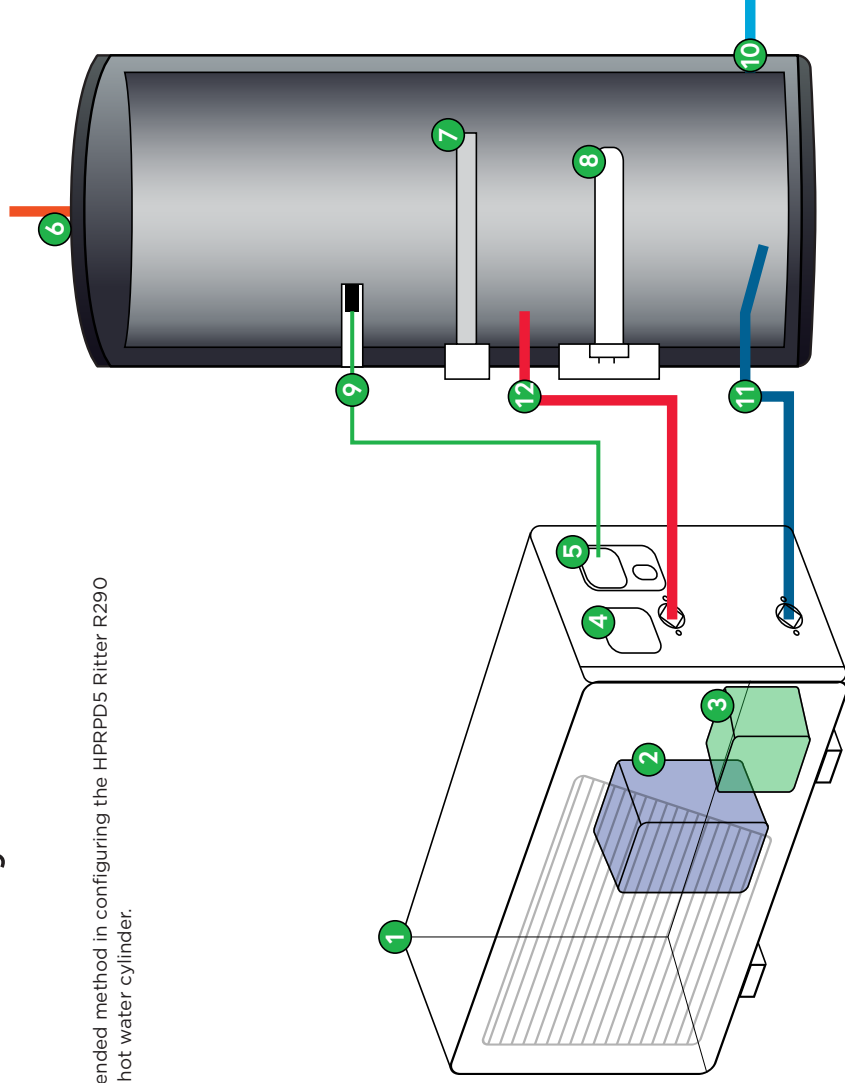



# QUICK GUIDE

## HPRPD5 Conventional Electric HWC/Protank+ cylinder configuration

The following guide, shows the recommended method in configuring the HPRPD5 Ritter R290 Hotwater heatpump to a standard hot water cylinder.

### Creating Probe Pocket



1

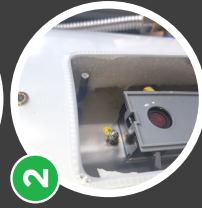

2

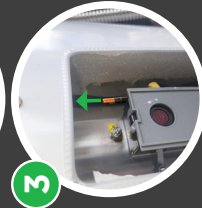

3

**Recommended method to mount the DHW probe:**  
Use a 6mm allen key to create a well against the inside skin of the cylinder.

Push the allen key up to create a well 75mm long, vertically above the element housing.

Thread the DHW probe through the cable gland and push into the well.

### KEY

1. Ritter R290 heatpump unit
2. Heat exchanger
3. Pump
4. Controller
5. Terminal Connections
6. Hotwater Cylinder
7. Probe Pocket
8. Electric Element
9. Probe - supplied in unit
10. Valve block
11. Heat Pump Return
12. Heat Pump Flow
13. TPR with tee
14. CWE with tee

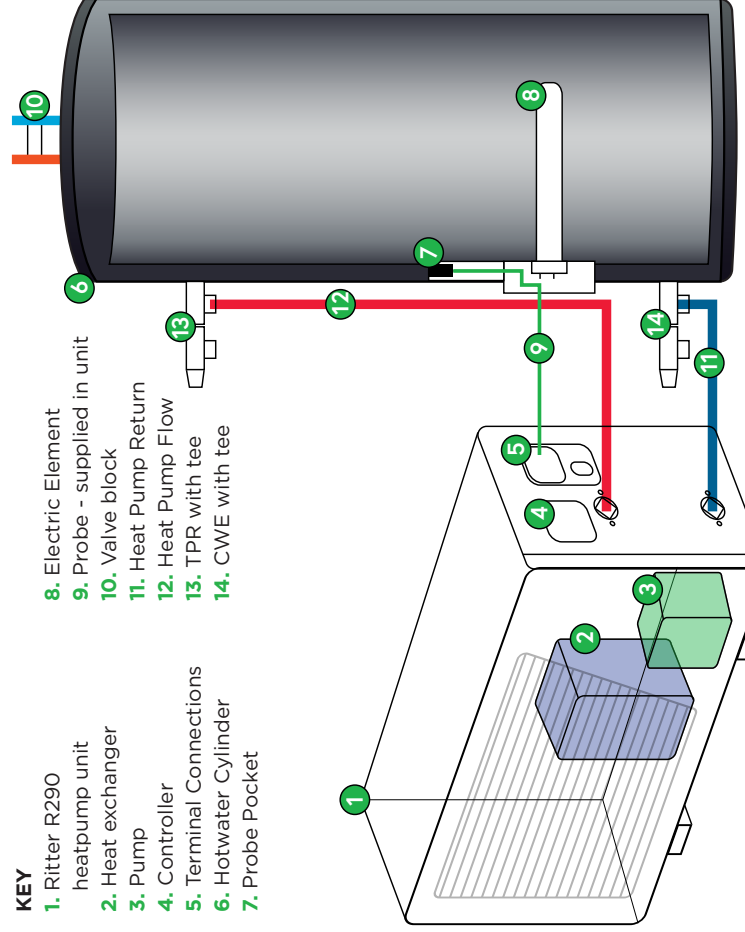

# QUICK GUIDE

## HRRPD5 Conventional Electric HWC/ Protank<sup>+</sup> cylinder configuration

### Compensating the probe reading:

After the cylinder has reached set point, draw water off the TPR & measure it's temperature.

Adjust parameter P26 value so the stated tank temperature matches the water temperature from the TPR.

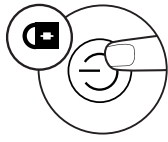

**1.** If the padlock is displayed on the display press the power button for 5s to unlock

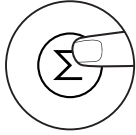

**2.** Press and hold the menu button for 10s to enter the L menu

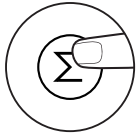

**3.** Press and hold the menu button again for 10s to enter the P menu

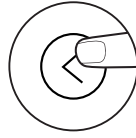

**4.** Press the up button to navigate to P26

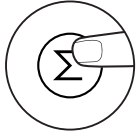

**5.** Press the M button to navigate to the P26 value

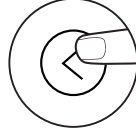

**6.** Press the up button to adjust the value to the required value

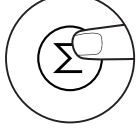

**7.** Press the M button to save the value

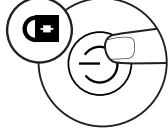

**8.** Press the power button to return to the main menu

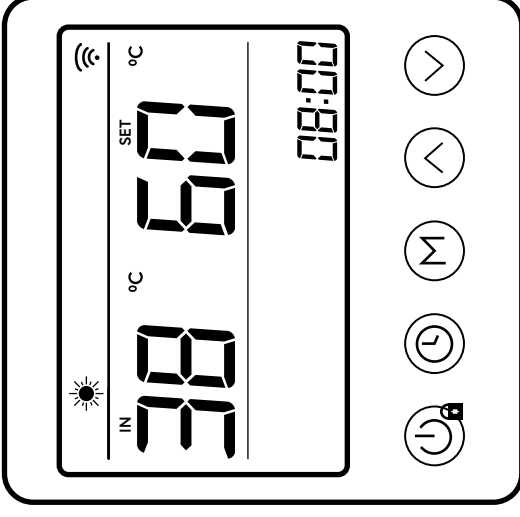

Your Ritter R290 Hotpad Controls.  
See page 11 for keypad information.

### Adjusting the reheat trigger:

Adjust parameter L17 to 4°C, this triggers the HP to start recovering the tank @ 56°C (60-4°C)

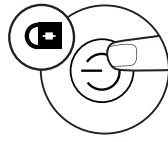

**1.** If the padlock is displayed on the display press the power button for 5s to unlock

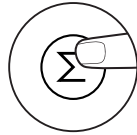

**2.** Press and hold the menu button for 10s to enter the L menu



**3.** Press the up button to navigate to L17

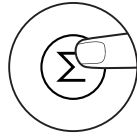

**4.** Press the M button to navigate to the L17 value

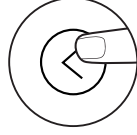

**5.** Press the up button to adjust the value to 4

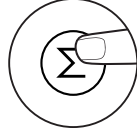

**6.** Press the M button to save the value

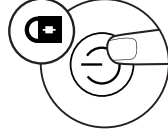

**7.** Press the power button to return to the main menu

# CHECK LIST

Below is a quick check list to confirm that all the steps have been followed when configuring the system.

- 1. DHW probe located in the tank.
- 2. TPR water temperature test completed.
- 3. Controller parameters adjusted.
- 4. Controller connected to wifi.
- 5. Hand over to customer completed.

Additional notes:

---

---

---

---

---

---

---

---

---

---

---



Powered by   
WATERWARE

*Proud members of*



**waterware.co.nz**  
**info@waterware.co.nz**  
**+64 9 273 9191**

