

Advanced electronic mixing valve with connectivity



© Copyright 2025 Caleffi

6003 series (24 V) LEGIOMIX[®] evo

Technical documentation:



INSTALLATION AND COMMISSIONING MANUAL



Operating principle

The electronic mixing valve is used in centralized systems that produce and distribute domestic hot water. Its function is to guarantee and maintain the temperature of the domestic hot water delivered to the user when there are variations in the temperature and pressure of the hot and cold water at the inlet or in the draw-off flow rate. The mixing valve is managed by an actuator that changes the mixed water temperature set position based on the signal from the temperature probes and under the control of a specific regulator. Appropriate relays are used to manage the alarms and external appliances, for example for filling the hot water storage and switching on/off the recirculation pump.

This particular series of electronic mixing valves is equipped with a specific regulator that controls a set of thermal disinfection programs for the circuit to combat Legionella. It also be used to check that the thermal disinfection temperature and time are actually reached and take the appropriate corrective action. All parameters are constantly updated and logged. Depending on the type of system and habits of the user, it is possible to program temperature levels and operation times in the most suitable manner.

The regulator is designed for remote management via Caleffi Cloud and using specific transmission protocols used in BACS (Building Automation and Control Systems).

Certain versions are equipped with an actuator incorporating a Failsafe feature; this function allows automatic closure of the hot line in the event that the electricity supply is cut off.

CONTENTS

Product range	2
Characteristic components (Package content)	2
Technical specifications	3
Individual component specifications	3
Operating principle	4
Digital regulator	5
Terminal board description	5
0–10 V and 3-point connections	6
Wall mounting	7
Connecting the electrical cables to the terminal board	7
Cable size specifications	8
Cable gland and closing plug locations	8
Configuration examples	9
Probe connection	10
Actuation relays	11
Hydraulic installation	12
Maintenance	13
Functional faults	13
Troubleshooting	13
Manual opening procedure	14
Application diagrams	15

Product range

6003.3 series Advanced electronic mixing valve with connectivity. 0–10 V control signal with Failsafe. Threaded version.

6003.4 series Advanced electronic mixing valve with connectivity. 3-point control signal without Failsafe. Threaded version.

sizes DN 20 (3/4") - DN 25 (1") - DN 32 (1 1/4") - DN 40 (1 1/2") - DN 50 (2")

60033. series. Advanced electronic mixing valve with connectivity. 0–10 V control signal with Failsafe. Flanged version.

60035. series. Advanced electronic mixing valve with connectivity. 0–10 V control signal without Failsafe. Flanged version.

sizes DN 65 and DN 80

Characteristic components (Package content)

1. Digital regulator.
2. Mixing valve.
3. Temperature gauge.
4. Actuator.
5. Flow probe.
6. Recirculation contact probe.
7. Storage probe (optional, code 600003).
8. Bag containing rubber cable gland kit.
9. Lever for manual opening (flanged versions only).
10. Bag containing wall mounting kit.
11. Manuals.

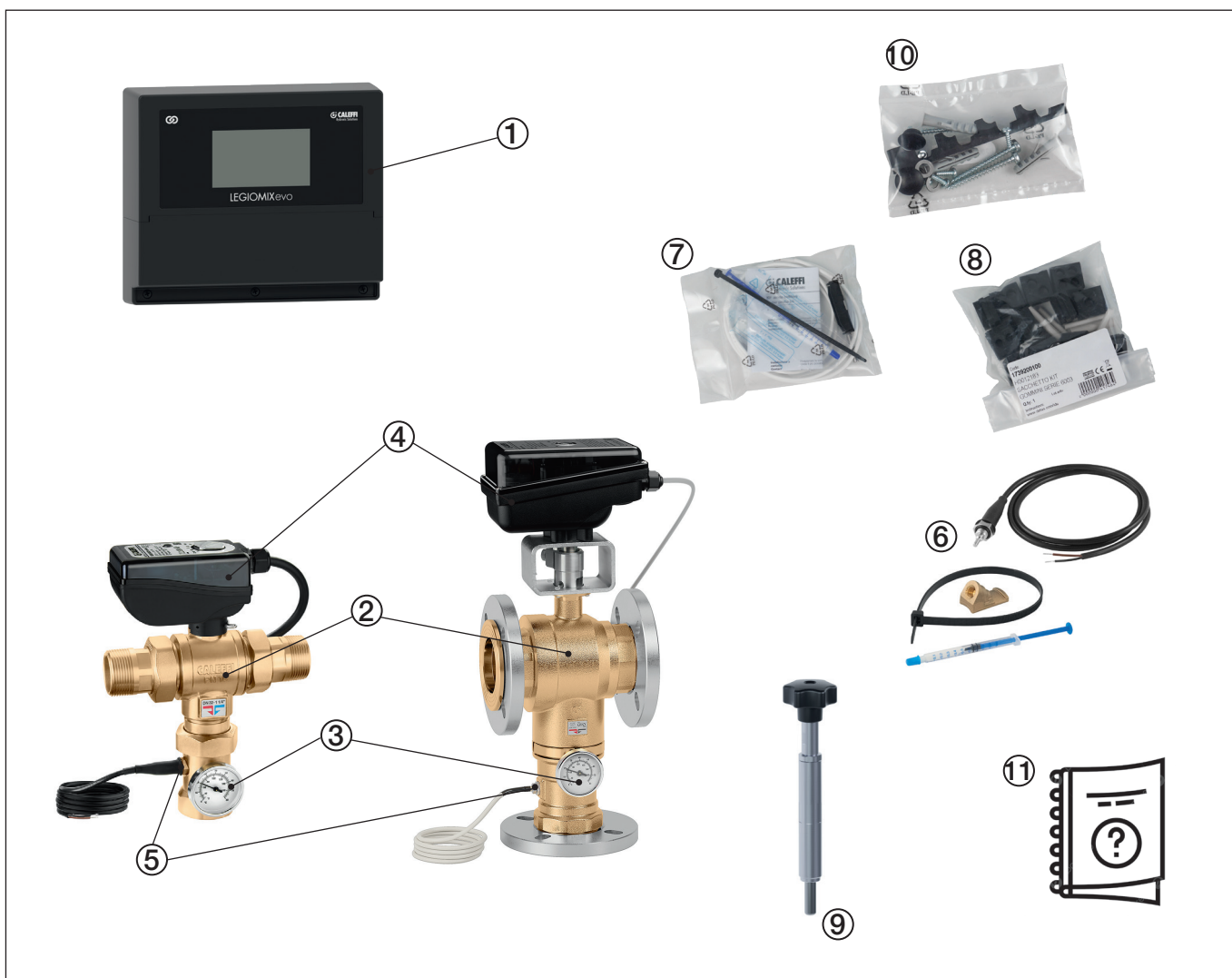

Technical specifications

Valve body

Materials:

Body: - threaded versions: "LOW LEAD" dezincification resistant alloy **CR**
EN 12165 CW724R

- flanged versions: "LOW LEAD" dezincification resistant alloy **CR**
EN 12165 CW724R

Ball: - 3/4" - 1 1/4" versions: "LOW LEAD" dezincification resistant alloy **CR**
EN 12165 CW724R, chrome plated

- 1 1/2" - 2" versions: "LOW LEAD" dezincification resistant alloy **CR**
EN 12165 CW724R, chrome plated, POM

- flanged versions: stainless steel AISI 316

Hydraulic seals: - threaded versions: EPDM
- flanged versions: NBR

Body nominal pressure: PN 16

Maximum working pressure: 10 bar

Maximum differential pressure: 5 bar

Medium working temperature range: 5–100 °C

Temperature gauge scale: 0–80 °C

Hot and cold water connections:

3/4"–2" M (EN 10226-1) with union

Mixed water connection: 3/4"–2" F (EN 10226-1) with union

Flanged connections: DN 65 and DN 80, PN 16 can be coupled with counterflanges EN 1092-1

System specifications

Electric supply: 24 V ~ (AC) ± 10 % 50/60 Hz

Average power absorption: 5 VA

Stand-by power consumption: 3,5 VA

Maximum power consumption	Regulator	Actuator	Total
Threaded	9 VA	6 VA	15 VA
Flanged		10 VA	19 VA

Ambient temperature:

Operation: 0–50 °C EN 60721-3-3 Cl. 3K4, max. humidity 95 %

Transportation: -30–70 °C EN 60721-3-2 Cl. 2K3, max. humidity 95 %

Storage: -20–70° C EN 60721-3-1 Cl. 1K2, max. humidity 95 %

Adjustment temperature range: 20–85 °C

Disinfection temperature range: 40–85 °C

Charge reserve: 15 days date/time preservation in the event of electric supply failure

Battery recharging time: 12 h

Cable for connection to the electricity mains

Use a cable with insulation that is the equivalent of H05VVf or higher, and with conductors that have a minimum cross-section of 0,75 mm² (1,5 mm² max).

Individual component specifications

Digital regulator

Display: touchscreen, capacitive colour, 4.3"

Box material: self-extinguishing ABS V0

Electric supply: 24 V ~ (AC) ± 10 % 50/60 Hz

Maximum power consumption: 9 VA

Average power absorption: 5 VA

Stand-by power consumption: 3,5 VA

Protection class: IP 54 (class II appliance)

Ambient temperature:

Operation: 0–50 °C EN 60721-3-3 Cl. 3K4, max. humidity 95 %

Transportation: -30–70 °C EN 60721-3-2 Cl. 2K3, max. humidity 95 %

Storage: -20–70° C EN 60721-3-1 Cl. 1K2, max. humidity 95 %

Contact rating:

3-point mixing valve control: 1A / 24 V ~ (AC)

Mixing valve control (0–10 V): signal 0–10 V = (DC) / 500 mA

Relay: 10(2) A / 24 V ~ (AC)

PTC self-recovery fuse: 30 V / 3.5 A

Compliance with Directives: CE, UKCA, FCC, IC

Additional digital regulator specifications (EN 60730-1)

Control type: Type 1

Environmental pollution grade: grade 2

Nominal pulse voltage: 500 V peak for overvoltage category II

Flow and recirculation temperature probes

Body material: stainless steel

Type of sensitive element: NTC

Working temperature range: -10–125 °C

Resistance: 10 kΩ at 25 °C

Cable length: 1 m

Storage temperature probe (OPTIONAL)

Body material: stainless steel

Type of sensitive element: NTC

Size: ø 6 mm

Working temperature range: -25–110 °C

Resistance: 100 kΩ at 25 °C

Cable length: 1,9 m

N.B. Cable extensions:

if necessary, extend the probe and actuator cables; contact the manufacturer.

Actuator for threaded version with Failsafe*

Electric supply: 24 V ~ / = (AC/DC) ± 15 % - 50/60 Hz directly from the regulator

Control signal: 0–10 V

Power consumption: 6 VA

Ambient temperature:

Operation: 0–55 °C EN 60721-3-3 Cl. 3K4, max. humidity 95 %

Transportation: -30–70 °C EN 60721-3-2 Cl. 2K3, max. humidity 95 %

Storage: -20–70° C EN 60721-3-1 Cl. 1K2, max. humidity 95 %

Supply cable length: 0,8 m

Actuator for threaded version without Failsafe*

Electric supply: 24 V ~ (AC) ± 10 % - 50/60 Hz directly from the regulator

Control signal: Three-point

Power consumption: 6 VA

Ambient temperature:

Operation: -10–55 °C EN 60721-3-3 Cl. 3K4, max. humidity 95 %

Transportation: -30–70 °C EN 60721-3-2 Cl. 2K3, max. humidity 95 %

Storage: -20–70° C EN 60721-3-1 Cl. 1K2, max. humidity 95 %

Supply cable length: 0,8 m

Actuator for flanged version with/without Failsafe*

Electric supply: 24 V ~ / = (AC/DC) ± 15 % - 50/60 Hz directly from the regulator

Control signal: 0–10 V

Power consumption: 10 VA

Ambient temperature:

Operation: 0–55 °C EN 60721-3-3 Cl. 3K4, max. humidity 95 %

Transportation: -30–70 °C EN 60721-3-2 Cl. 2K3, max. humidity 95 %

Storage: -20–70° C EN 60721-3-1 Cl. 1K2, max. humidity 95 %

Supply cable length: 1,9 m

*The Failsafe function allows automatic closure of the hot line in the event that the electricity supply is cut off.

Additional actuator specifications (EN 60730-1/-2-14)

Protection cover: self-extinguishing V0

Protection class: IP 65

Compliance with Directives: CE, UKCA, FCC, IC

Control type: Type 1

Environmental pollution grade: grade 2

Activation type: multi-position

Nominal pulse voltage: 500 V peak for overvoltage category II

Dynamic torque (threaded versions): 15 Nm

Dynamic torque (flanged versions): 35 Nm

Mixing valve performance

Accuracy: $\pm 2 \text{ }^\circ\text{C}$
 Maximum differential pressure (dynamic): 5 bar
 Maximum inlet pressure ratio (H/C or C/H) with $G > 0,5 \text{ Kv}$: 2:1

Size	3/4"	1"	1 1/4"	1 1/2"	2"	DN 65	DN 80
Kv (m³/h)	8,4	10,6	21,2	32,5	41,0	90,0	105,0

RECOMMENDED flow rates to ensure stable operation

Size	3/4"	1"	1 1/4"	1 1/2"	2"	DN 65	DN 80
G _{min} (m³/h)	0,5	0,7	1,0	1,5	2,0	4,0	5,0
G _{max} (m³/h)*	10,3	13,2	28,1	39,0	48,3	110,0	150,0

* $\Delta p = 1,5 \text{ bar}$

Operating principle

At the inlets the mixing valve has the hot water from the storage and the cold water from the water mains. At the outlet there is the flow mixed water. By means of a specific probe, the regulator measures the temperature of the mixed water at the valve outlet and triggers the mixing valve in order to maintain the set temperature.

The appliance has a built-in digital clock, which can be used to set anti-legionella programs to disinfect the water system. The system is disinfected by raising the water temperature to a specific value for a set time duration.

For the best thermal disinfection control, in this type of system it may also be necessary to measure the temperature of the water returning from the distribution network, using the recirculation probe. When this measurement is available, it is used to check and control the temperature reached over all or part of the network, since the probe may be located at a significant remote point of the system.

The storage probe (optional) is used to monitor the storage temperature of the hot water.

The appliance is equipped with RS-485 and Ethernet interfaces with Modbus/BACnet* protocol for remotely setting the operating parameters and monitoring the functions. Dedicated relays can activate alarm signals and commands for other system devices.

Control types

1. Display;
 2. Dashboard (Caleffi Cloud via Ethernet interface 1 (Eth1));
 3. Modbus/BACnet* system (external Building Automation system management via Ethernet interface 2 (Eth2) or RS-485 interface).
- *BACnet: available at completion of the certification process

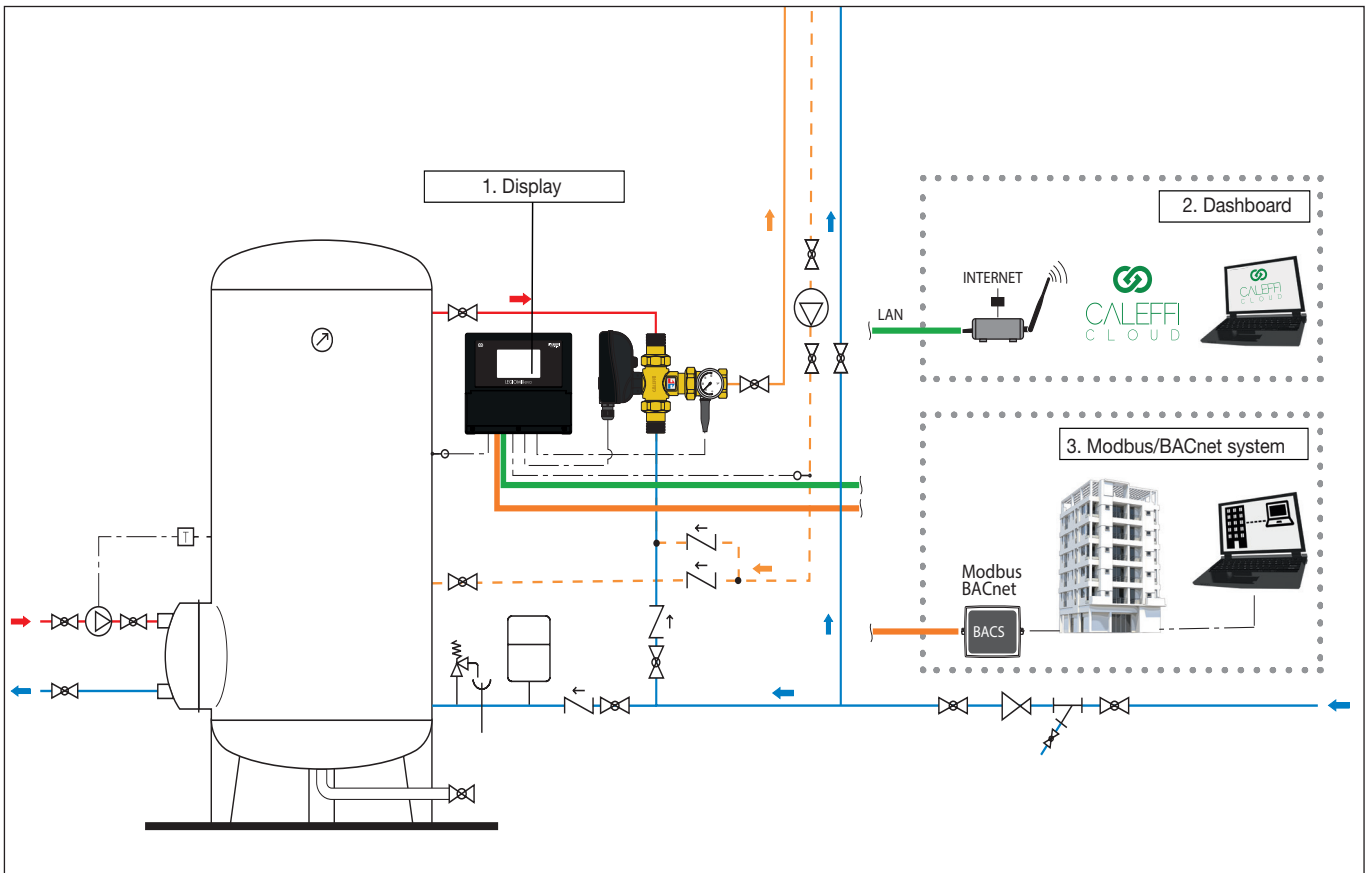

Digital regulator

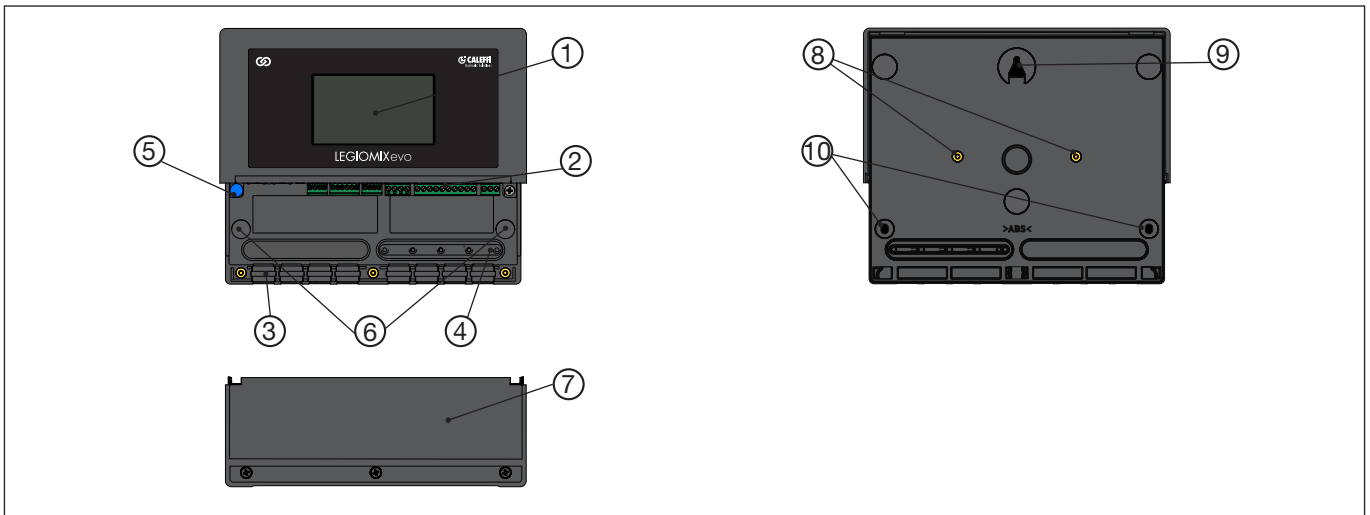

1. Touch display
2. Terminal board
3. Sealed cable gland
4. Cable gland
5. Tamper-proof seal

6. Knock-outs for bracketing
7. Removable cover
8. Holes for DIN rail mounting
9. Support point
10. Mounting holes

Terminal board description

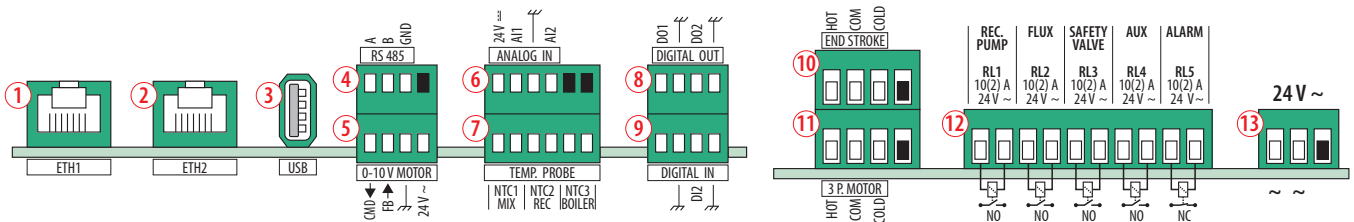

1. Ethernet port 1 (Caleffi Cloud connectivity)
2. Ethernet port 2 (Modbus/BACnet communication protocol)
3. USB port
4. RS-485
5. 0-10 V actuator control
6. Analogue input
7. NTC type probes:
 - 1) NTC1 flow probe
 - 2) NTC2 recirculation probe
 - 3) NTC3 storage probe
8. Digital output
9. Digital input

10. 3-point motor end stroke
11. 3-point motor control
12. Relays (voltage-free)
 - 1) RL1 RECIRCULATION PUMP relay - NO
 - 2) RL2 FLUSH relay - NO
 - 3) RL3 SAFETY relay - NO
 - 4) RL4 AUXILIARY relay - NO
 - 5) RL5 ALARM relay - NC
13. Electric supply

Important:

Alternative connections, depending on the motor type (see page 6)

Important:

Alternative connections, depending on the connection type (see page 9)

USB port

The USB port is to be used for downloading data only (refer to "Programming Manual" code 04750). It cannot be used to supply devices.



CAUTION: Electric shock risk. The regulator and mixing valve contain live circuits. Cut off the electric supply before carrying out any work. Failure to follow these instructions may result in injury of persons or damage to property and the electronics in use.

0-10 V and 3-point connections



There are two alternative types of connection for controlling the actuators. It is therefore essential NOT to connect them simultaneously. The connection diagrams are shown below. Follow the cable colours strictly.

Threaded version With Failsafe (0-10 V)

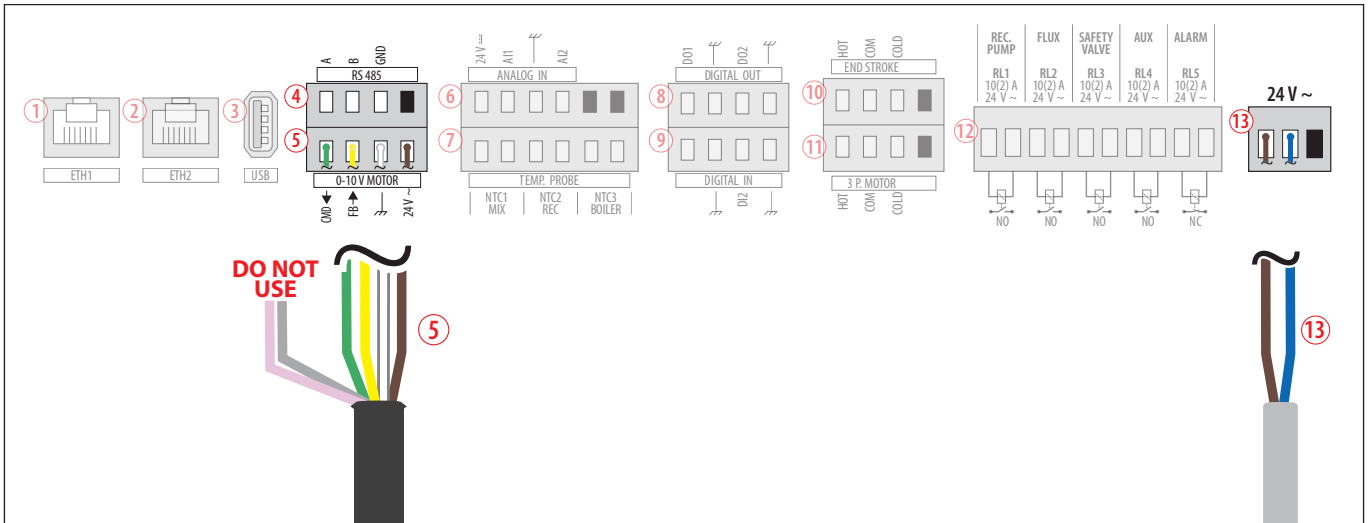

Without Failsafe (3-point)

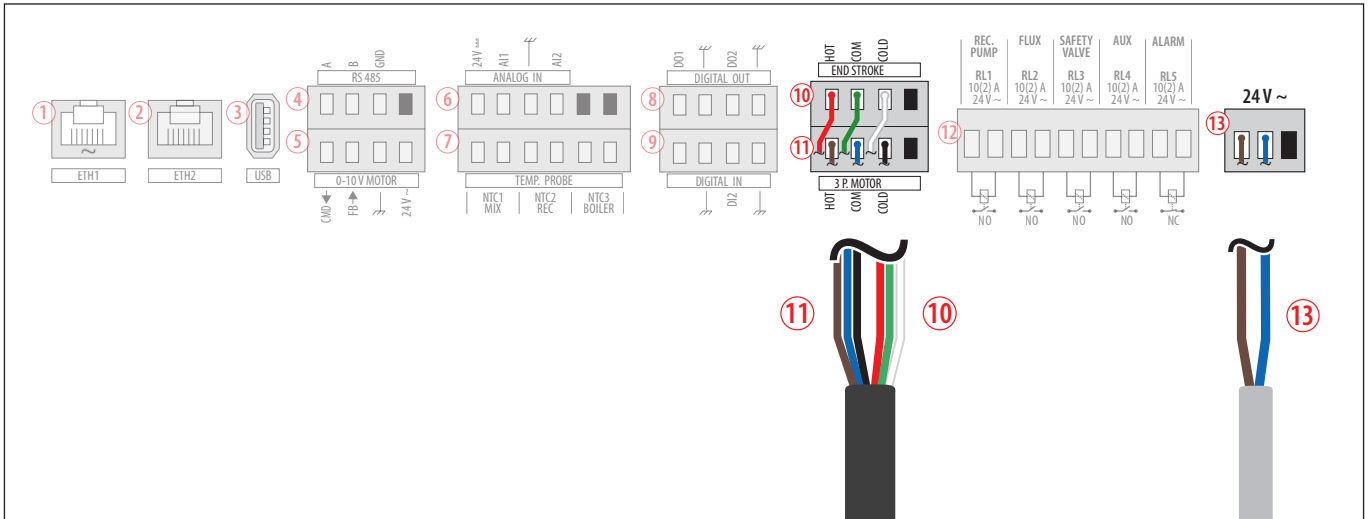

Flanged version With and without Failsafe (0-10 V)

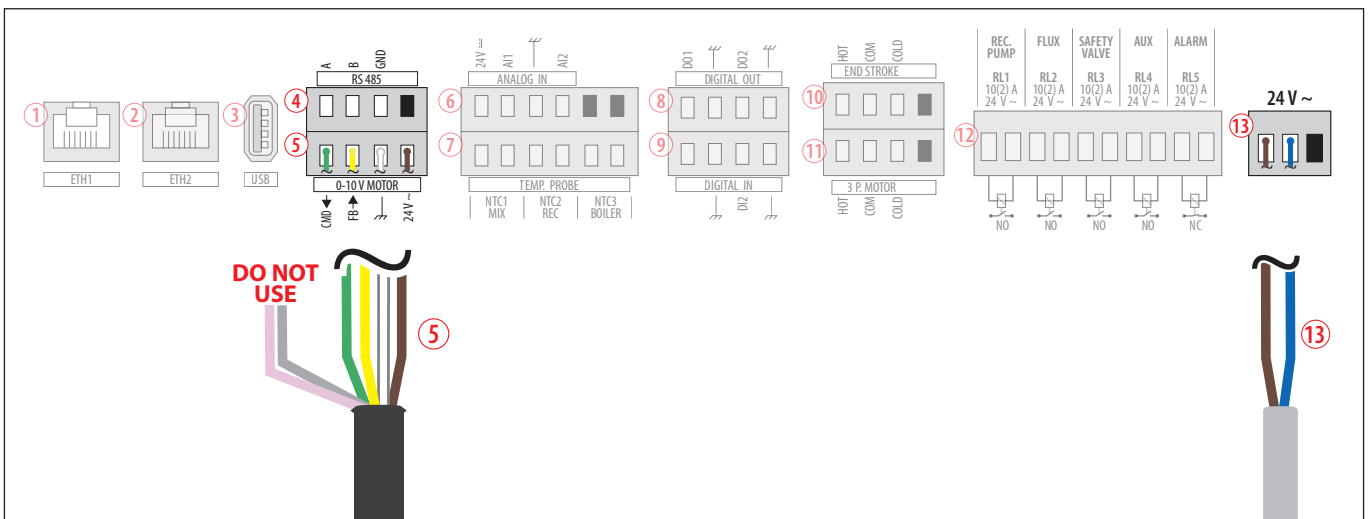

Wall mounting

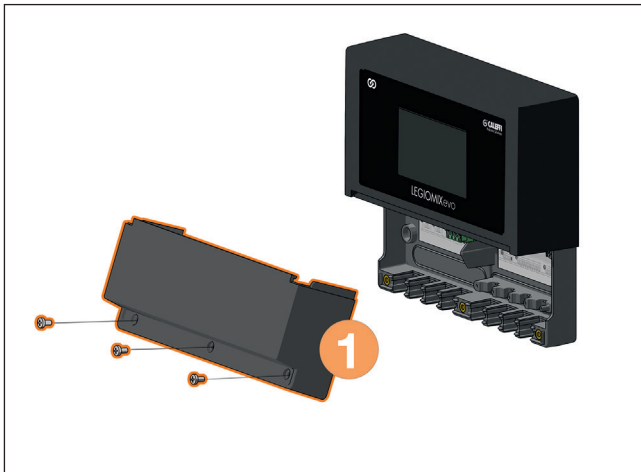

1- Remove the cover by undoing the three screws at the bottom, then turn the cover and lift it.

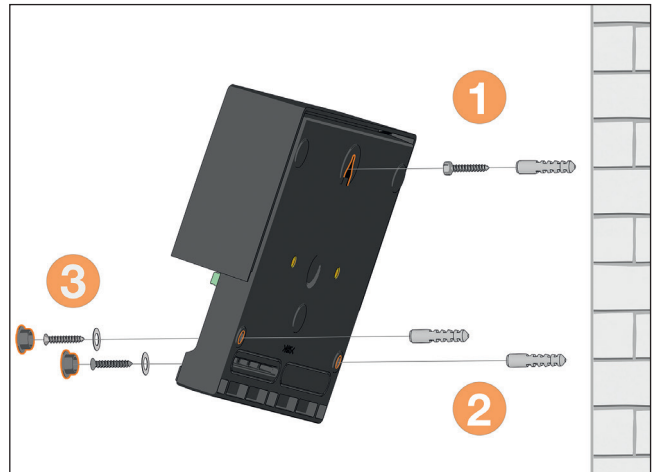

Secure the digital regulator with the three wall mounting points.
 1- Attach the regulator to the top mounting point.
 2- Secure the regulator with the screws that correspond to the bracketing holes.
 3- Inset the closing plugs.

Connecting the electrical cables to the terminal board

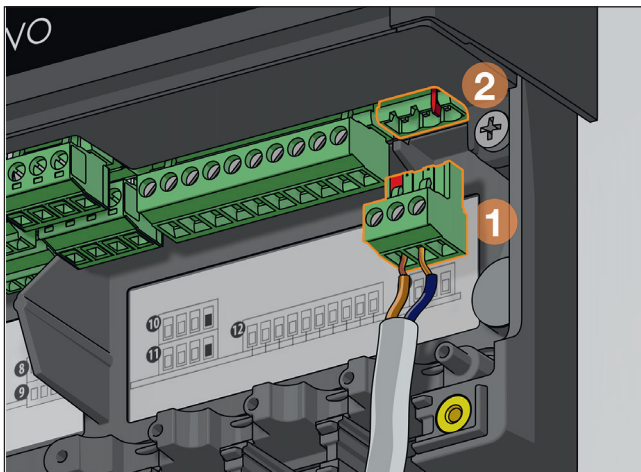

Connect the electrical cables with the corresponding removable connectors.

1- Connect the cables to the connector.
 2- Connect the connector to the terminal board on the regulator.
IMPORTANT: connect the electric supply last.

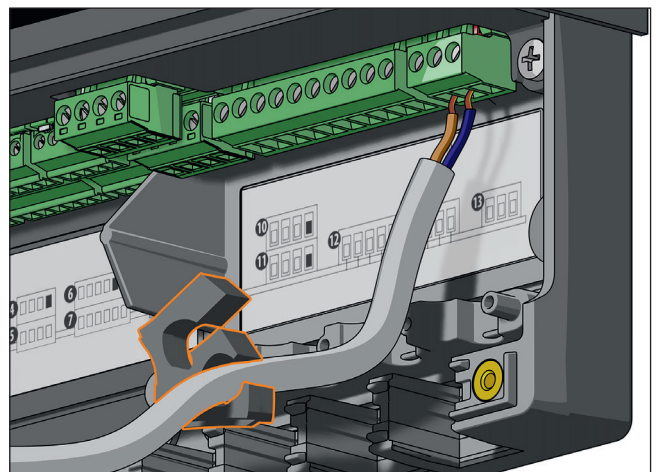

Insert the cables and plugs into the corresponding rubber cable glands through the slots in the side.

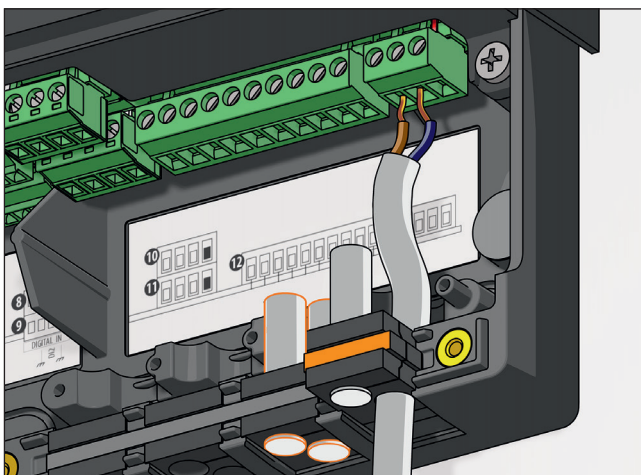

Insert the rubber cable glands into their housing and make sure that the side with the groove is at the top and that the cable insertion slots are on the right. This will ensure the IP54 seal. Make sure the plugs are flush with the outside.

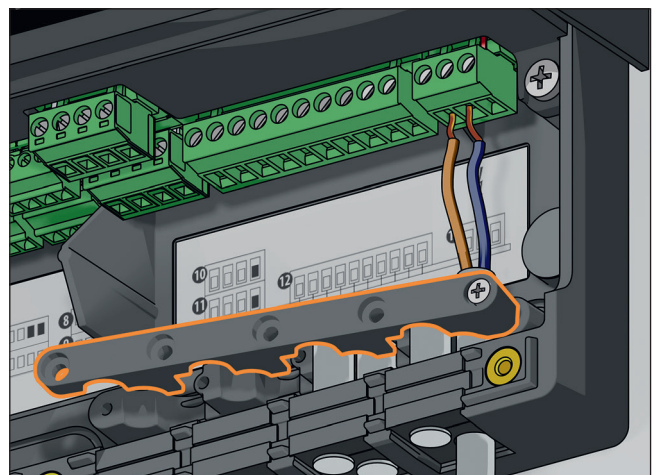

Once the cables and rubber cable glands have been mounted, fit the strain-relief cable glands. Refit the cover and secure it with the screws to ensure that the electrical connections are protected properly.

Cable size specifications

Dimensional characteristics to respect for circuit board wiring: connection cable cross-sections

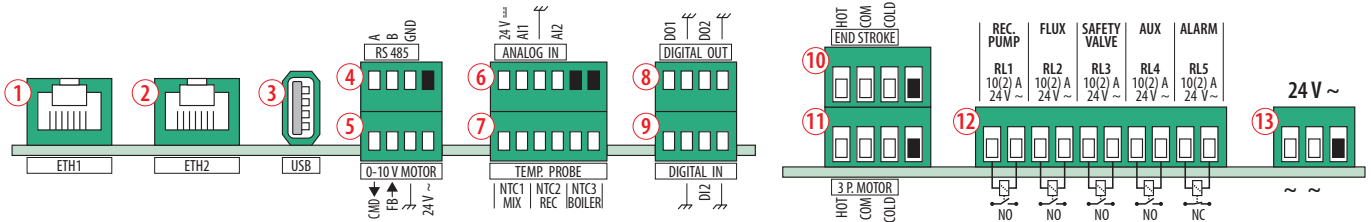

Connectors	Name	Cable diameter [mm]	Wire cross sections [mm ²]
1	ETH1	5 (cat. 5) 6 (cat. 6)	-
2	ETH2	5 (cat. 5) 6 (cat. 6)	-
3	USB	-	-
4	RS-485	5	-
5	0-10 V MOTOR	7	6 x 0,5 mm ²
6	ANALOG IN	5	-
7	TEMP. PROBE	5	2 x 0,5 mm ²
8	DIGITAL OUT	5	-
9	DIGITAL IN	5	-
10	END STROKE	9	6 x 0,75 mm ²
11	3 POINT MOTOR		6 x 0,75 mm ²
12	RELAY	7	-
13	POWER SUPPLY	7	-

Cable gland and closing plug locations

Rubber cable gland type		Plugs			
(no. of holes x Ø)	Quantity	Ø	Quantity		
2 x 7 mm		3	7 mm		1
1 x 9 mm		1	-	-	-
4 x 4 mm		1	4 mm		4
4 x 6 mm		1	6 mm		3
2 x 5 mm		2	5 mm		2
1 x 7 mm		1	-	-	-
Closed rubber cable gland		4	-	-	-

There are 8 holes in the bottom of the regulator body for fitting the cable glands. Fit the multi-hole cable glands in the desired configuration in order to ensure strain relief and IP54 seal on the cables. To ensure the protection class, seal unused holes with suitable closing plugs.

Configuration examples

Minimum 0-10 V configuration

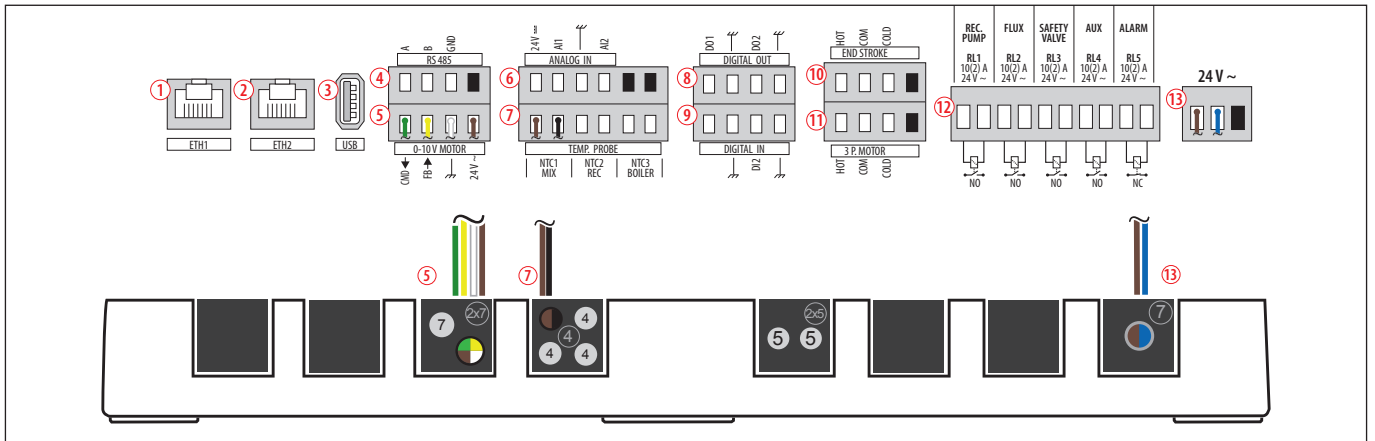

Complete 0-10 V - Eth2 configuration

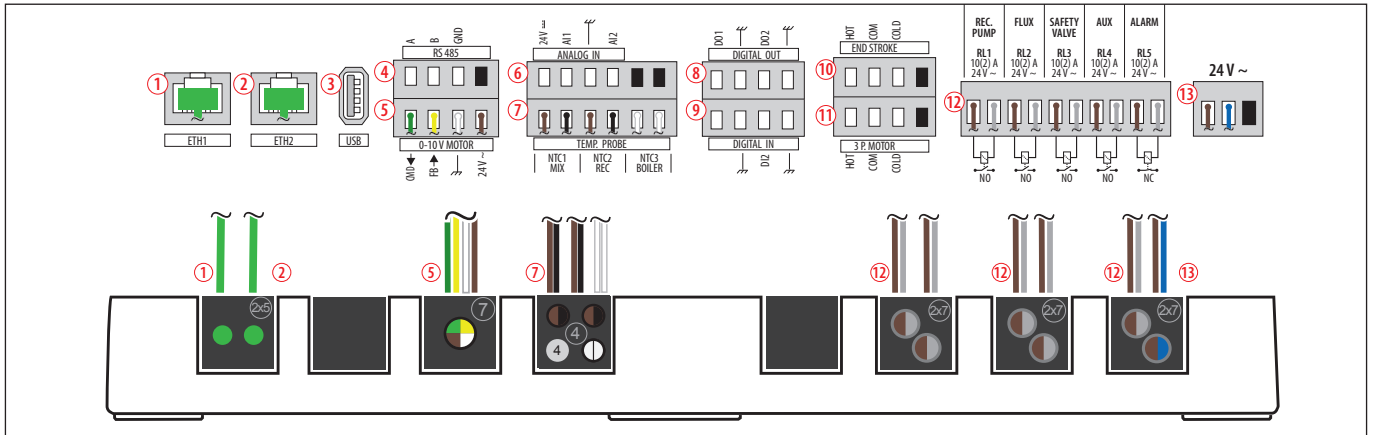

Minimum 3-point configuration

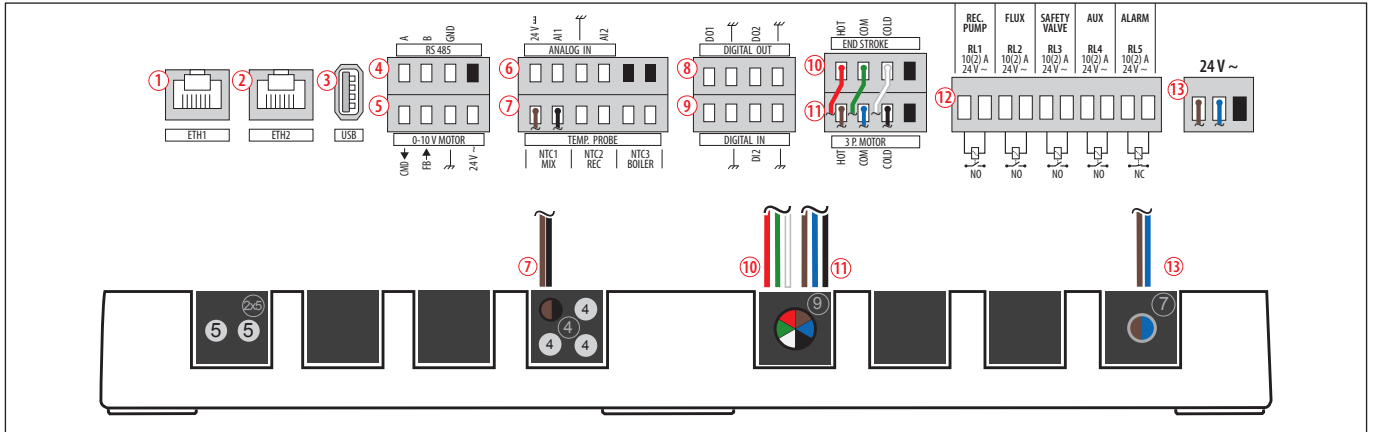

Complete 3-point - RS-485 configuration

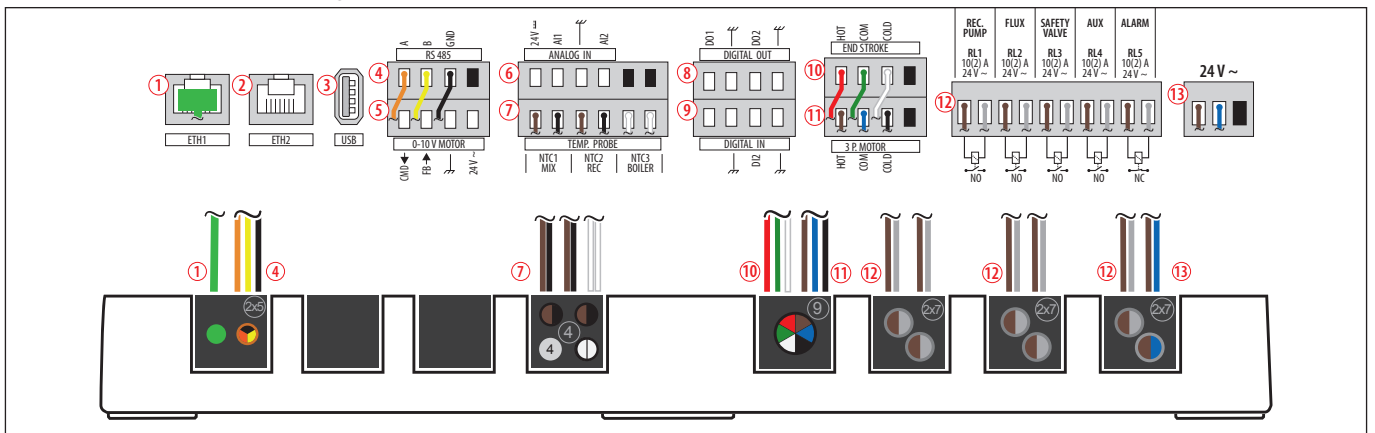

Probe connection



The cable connecting the flow and recirculation probes and the regulator must be installed in a dedicated raceway.

Probe resistance table (flow and recirculation)

°C	Ω	°C	Ω	°C	Ω	°C	Ω
-20	97060	20	12493	60	2488	100	680
-15	72940	25	10000	65	2083	105	592
-10	55319	30	8056	70	1752	110	517
-5	42324	35	6530	75	1480	115	450
0	32654	40	5327	80	1255	120	390
5	25396	45	4370	85	1070	125	340
10	19903	50	3603	90	915		
15	15714	55	2986	95	787		

Probe resistance table (storage)

°C	kΩ	°C	kΩ	°C	kΩ	°C	kΩ
-25	1527	10	208	45	41,3	80	10,8
-20	1118	15	162	50	33,5	85	9,2
-15	826	20	127	55	27,5	90	7,7
-10	616	25	100	60	22,6	95	6,6
-5	464	30	79,4	65	18,7	100	5,6
0	352	35	63,5	70	15,5	105	4,8
5	269	40	51	75	12,9	110	4,1

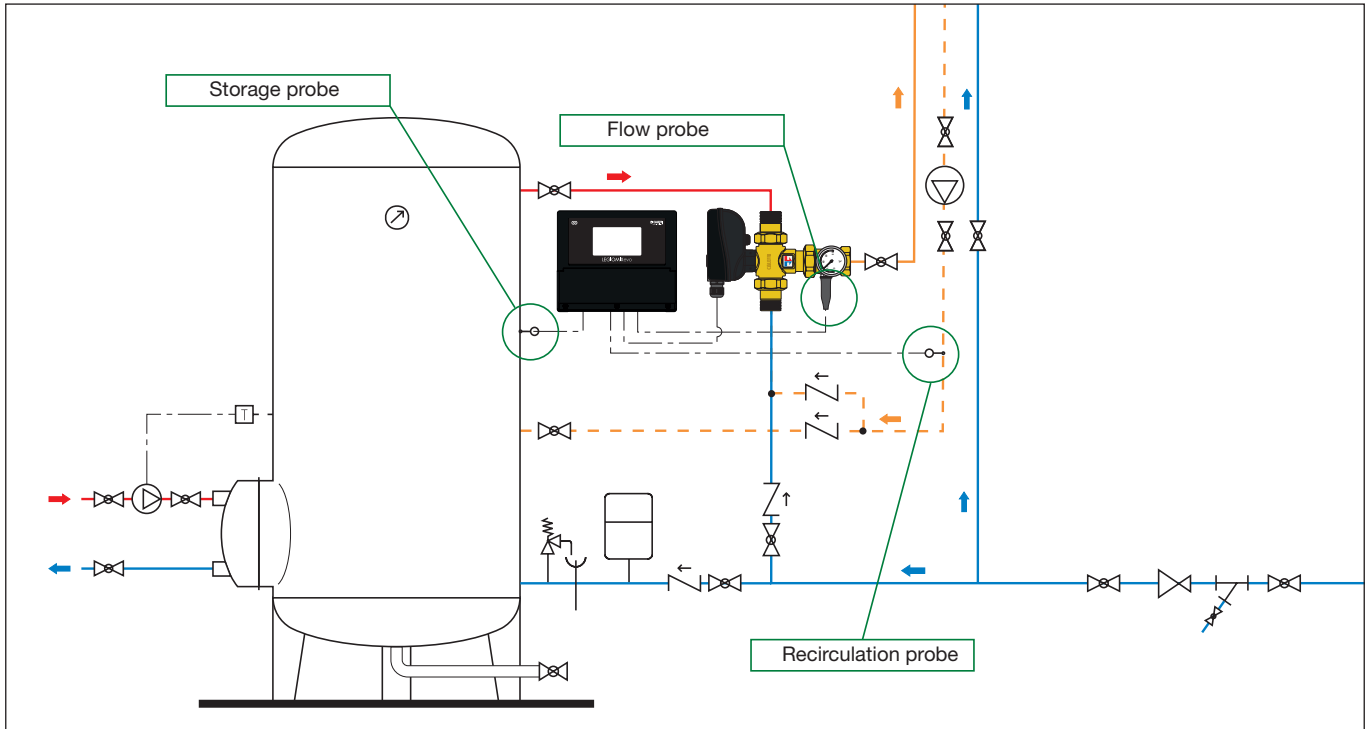

Carry out the hydraulic installation of the temperature probes and the electrical wiring

Actuation relays

Contact for recirculation pump (RL1)

The contact closes to start the pump according to the time slots set on the digital regulator or during the disinfection and thermal shock phases.

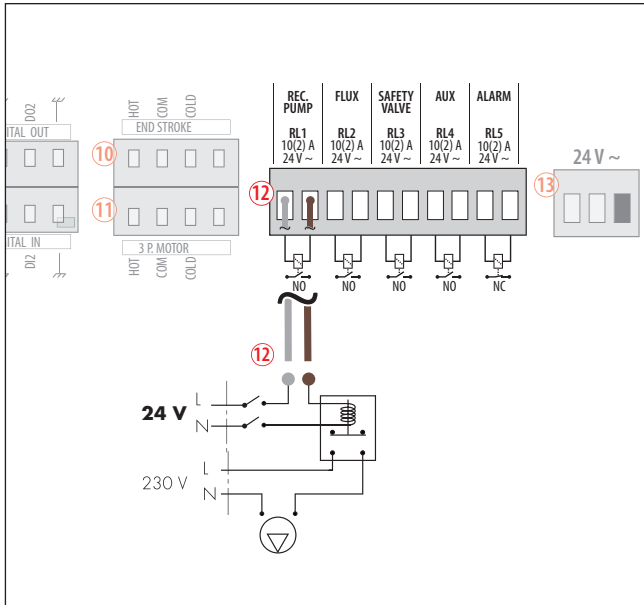

Contact for flush valve (RL2)

The contact closes to open the flushing valve at the end of the disinfection phase in order to restore the circuit temperature to its operating value faster.

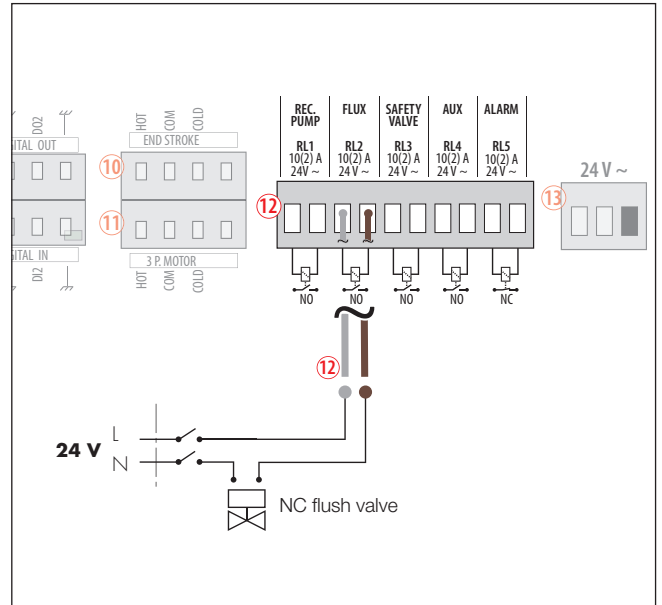

Contact for temperature restriction safety valve (RL3) Solenoid valve

The regulator keeps the contact closed during normal operation. If the temperature rises above the danger level, the contact opens to activate the temperature restriction valve.

If the solenoid valve is of the normally open type, an SPDT switch relay must be fitted.

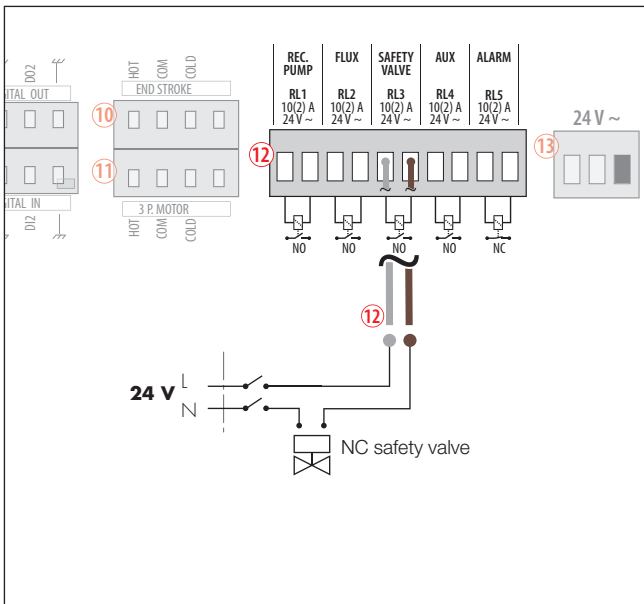

Contact for temperature restriction safety valve (RL3) 3-contact motorised valve

The regulator keeps the contact closed during normal operation. If the temperature rises above the danger level, the contact opens to activate the temperature restriction valve.

Fit a changeover switch relay to ensure the three-contact motorised valve operates correctly.

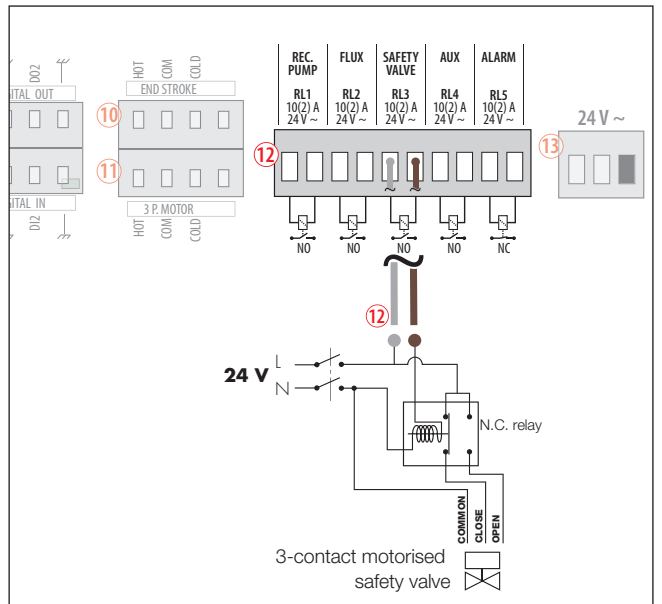

Auxiliary contact for second storage thermostat (RL4)

The auxiliary contact can be used to raise the storage temperature during the disinfection phases.

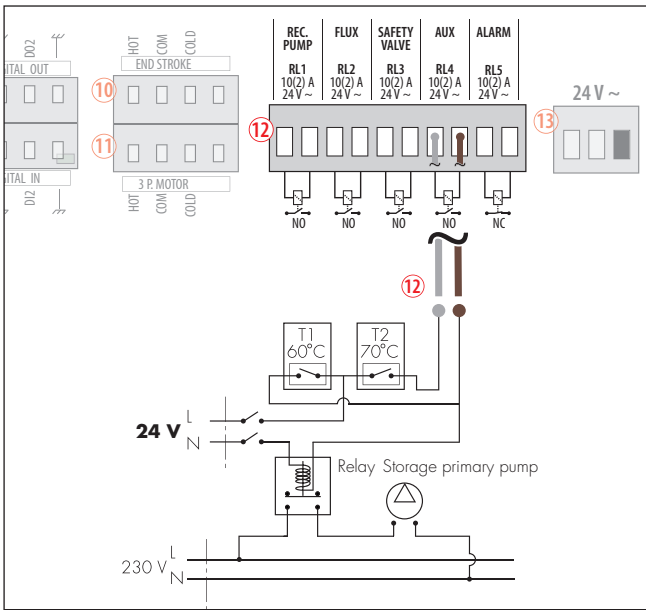

Contact for alarm management (RL5)

The contact remains open during normal operation. In the event of an alarm or electric supply failure, the contact closes to activate a warning buzzer and/or light.

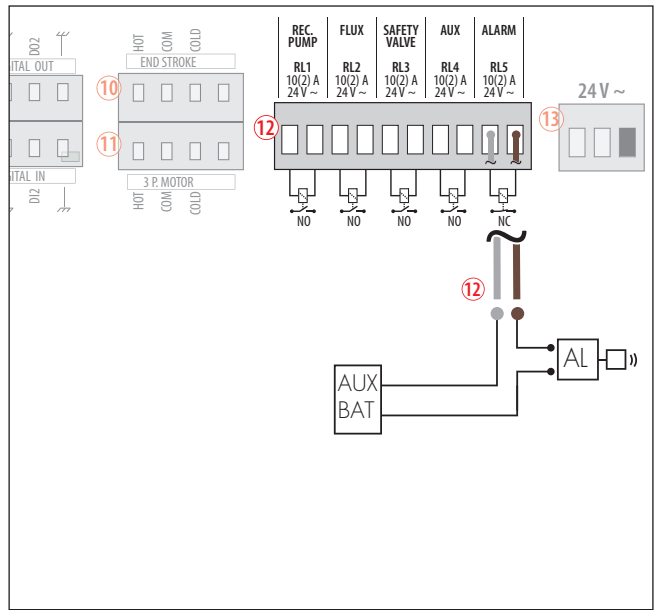

Hydraulic installation

Before installing the Caleffi mixing valve, the pipes must be flushed to prevent impurities in the water from affecting performance.

We recommend always installing strainers of sufficient capacity at the inlet from the water mains.

If the system is washed with chemicals, leave the relevant flow temperature probe housing end plug on.

For subsequent washing procedures, disconnect the temperature probe and fit the relevant plug.

Only connect the probe **after** washing has been completed.



Caleffi electronic mixing valves must be installed as illustrated by the installation diagrams in this manual, in a suitable location and taking account of applicable current regulations.

Caleffi electronic mixing valves may be installed either vertically or horizontally, but the actuator must not be upside down.

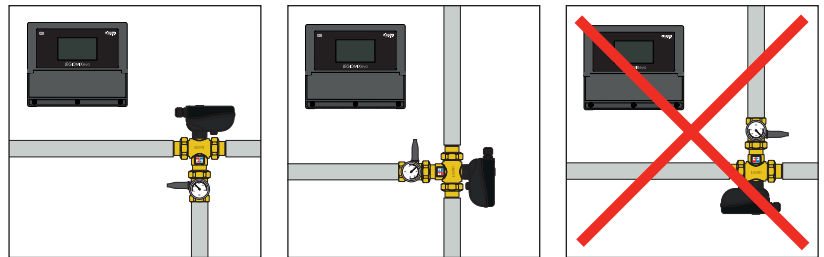

The following are indicated on the body of the mixing valve:

- Hot water inlet with red arrow.
- Cold water inlet with blue arrow.



Check valves

In systems with mixing valves, check valves should be fitted to prevent undesired medium returns, as shown in the section "Application diagrams". We recommend always installing strainers of sufficient capacity at the inlet of the water mains and shut-off valves for any maintenance operations.

Commissioning

Due to the special purposes for which the electronic mixing valve will be used, it must be commissioned in accordance with current regulations and by qualified personnel using suitable measuring instruments. Check that the hot and cold water supply pressures are within the operating limits of the mixing valve. Check the temperature of the hot water from the storage, $T \geq 60\text{ }^{\circ}\text{C}$.

In the system log book, record all the parameter settings made and the measurements taken.

Maintenance

Tests are carried out while in service, to regularly monitor the performance of the mixing valve, since any loss of performance may indicate the need for maintenance of the valve and/or the system. During these tests, if the temperature of the mixed water is found to have changed significantly compared with previous tests, we recommend referring to the sections on **Hydraulic installation** and **Commissioning** and carrying out maintenance. We recommend carrying out the following checks periodically to ensure that the valve continues to deliver optimum levels of performance. At least every 12 months, or more frequently if required.

1. Check and clean the strainers in the system;
2. Check that any check valve installed at the inlet of the Caleffi valve is functioning correctly, and there are no leaks caused by dirt;
3. The internal components of the valve can be descaled by immersing them in a suitable descaling liquid. This is essential in systems that are used seasonally, for example in hotels and similar establishments;
4. After checking any components subject to maintenance, repeat the mixing valve commissioning procedure.

On the system log book, record all operations carried out.

Functional faults

A special set of alarms has been fitted to help manage possible faults that can occur in the device. Refer to the dedicated section of the "Programming Manual" (code 04750).

Troubleshooting

In normal operating conditions, Caleffi series 6003 electronic mixing valves provide outstanding performance. However, in special circumstances when our maintenance schedule is not observed, the following problems may arise:

Problem	Cause	Solution
Hot water supplied to cold water taps.	<ol style="list-style-type: none"> a. Inlet check valves not operating correctly or seals worn/damaged; b. Check valves not fitted. 	<ul style="list-style-type: none"> - Replace damaged check valves; - Install check valves.
Mixed water temperature fluctuations.	<ol style="list-style-type: none"> a. Insufficient recirculation flow rate; b. Variations in network pressure; c. Incorrect recirculation circuit connection; d. Incorrect installation. 	<ul style="list-style-type: none"> - Ensure the minimum flow rate; - Stabilise the water pressure; - Make sure the application diagrams have been observed.
Insufficient or incorrect valve outlet flow rate.	<ol style="list-style-type: none"> a. Clogged strainers; b. Jammed check valves; c. No water supply at the cold and/or hot inlet. 	<ul style="list-style-type: none"> - Check strainers and check valves in the system.

Manual opening procedure



Cut off the electric supply before carrying out any work.
For actuators with the Failsafe function, even after disconnecting the electric supply, wait for the motion to stop before operating the valve by hand.
Wait for the indicator LEDs to switch off completely at the end of the Failsafe function.
For detailed information regarding LED status, please refer to the programming manual.

Threaded versions

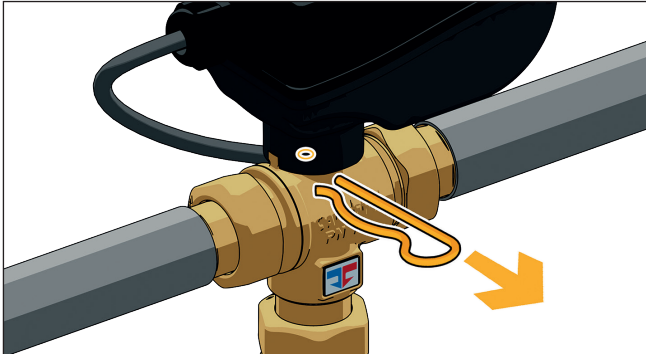

Remove the actuator from the valve body.

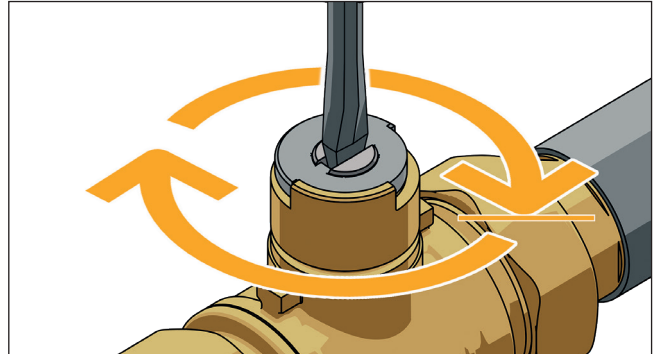

Turn the valve to the desired position by hand with a screwdriver.

Flanged versions

To perform manual opening, in the case of a fault or power failure, proceed as follows:

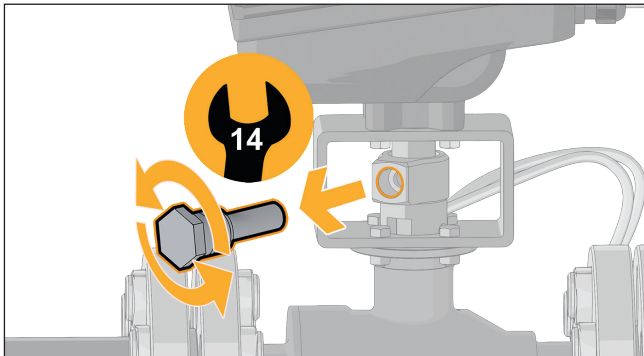

1. Unscrew the threaded locking pin using a 14 mm wrench.

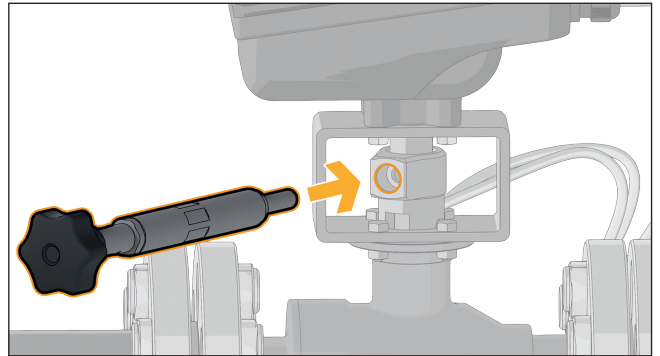

2. Screw the specific lever (supplied) into the locking pin hole.

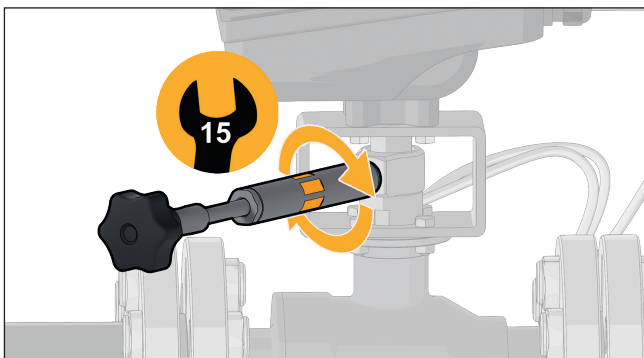

3. Lock the lever in position using the specific locknut with a 15 mm fixed wrench.

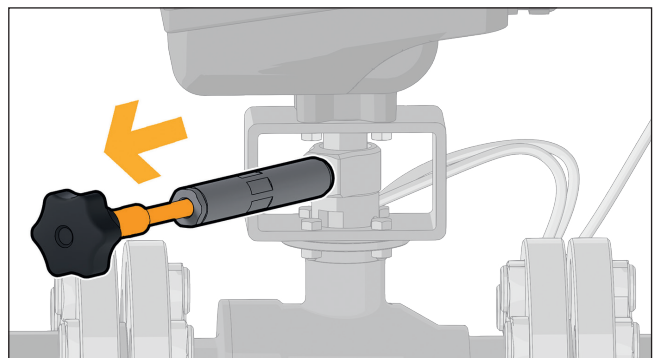

4. Pull the knob outwards.

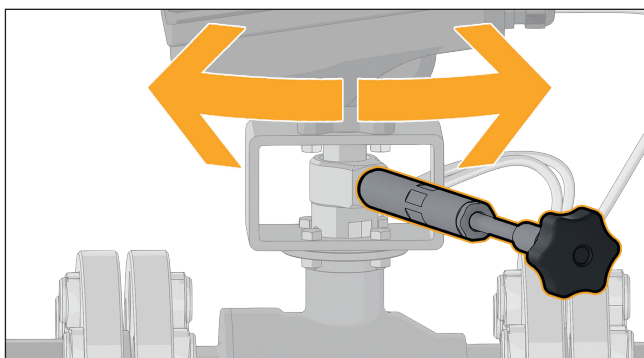



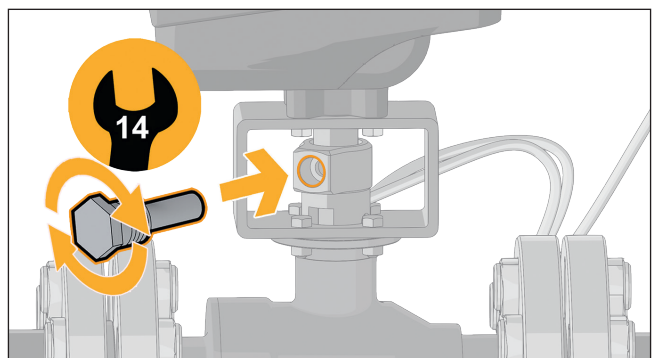





5. Turn the valve to the desired position. During these operations take precautions to avoid the danger of scalding to users.



6. When the procedure is complete, realign so that the knob engages and screw the locking pin back into its threaded hole.

Application diagrams

-  Check valve
-  Ball valve
-  Temperature gauge
-  Pressure reducing valve
-  Pump
-  Expansion vessel
-  Thermostat
-  Safety relief valve
-  Strainer

